



**est**  
EGYPTIAN  
SCHOLASTIC  
TEST

# EST PREP BLACK BOOK

## Summary Book

**"The Most Effective EST  
Strategies Summarized  
Ever Published"**

EST I Mathematics

# **TABLE OF CONTENTS**

**1- PRE-ALGEBRA BASICS AND  
STRATEGIES**

**2- PROBABILITY**

**3- ALGEBRA BASICS**

**4- FUNCTIONS**

**5- GEOMETRY**

**Multiple Choice**

Identify the choice that best completes the statement or answers the question.

What is the length of the hypotenuse of the right triangle shown?

1.

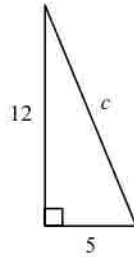

- a. 17                      b. 13                      c. 7                      d. 4.1

What is the side length  $b$  in the triangle below?

2.

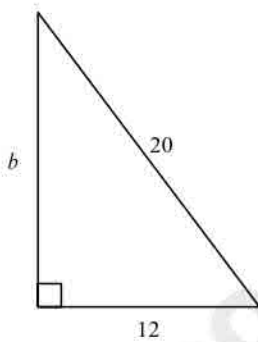

- a. 8                      b. 16                      c. 2.8                      d. 23.3

Can the set of lengths be the side lengths of a right triangle?

3. 18 m, 24 m, 30 m  
 a. yes                      b. no
4. 7 ft, 12 ft, 17 ft  
 a. no                      b. yes

Simplify the radical expression.

5.  $\sqrt{12h^4}$   
 a.  $2\sqrt{3h^4}$                       c.  $2h^2\sqrt{3}$   
 b.  $h\sqrt{6}$                       d.  $4\sqrt{3h^4}$

6.  $\sqrt{20h^6k^4}$   
 a.  $4\sqrt{5h^6k^4}$   
 b.  $2\sqrt{5h^6k^4}$   
 c.  $2h^3k^2\sqrt{5}$   
 d.  $hk\sqrt{10}$

7.  $2\sqrt{10} \cdot 3\sqrt{12}$   
 a.  $12\sqrt{60}$   
 b.  $5\sqrt{120}$   
 c.  $12\sqrt{30}$   
 d.  $6\sqrt{120}$

8.  $\sqrt{14q} \cdot 2\sqrt{4q}$   
 a.  $3\sqrt{56q^2}$   
 b.  $4q\sqrt{14}$   
 c.  $2\sqrt{56q^2}$   
 d.  $4\sqrt{14q^2}$

Simplify the radical expression.

9.  $\sqrt{\frac{80w^3}{9}}$   
 a.  $\frac{w\sqrt{80w}}{3}$   
 b.  $\frac{4w\sqrt{5w}}{3}$   
 c.  $\frac{\sqrt{80w^3}}{3}$   
 d.  $3\sqrt{w^3}$

10.  $\sqrt{\frac{10}{121}}$   
 a.  $\frac{\sqrt{10}}{61}$   
 b.  $11\sqrt{10}$   
 c.  $\frac{\sqrt{10}}{11}$   
 d.  $\frac{10}{11}$

11.  $\sqrt{\frac{63x^{15}y^9}{7xy^{11}}}$   
 a.  $\frac{8x^7y^4\sqrt{xy}}{\sqrt{7xy^{11}}}$   
 b.  $\frac{3x^7}{y}$   
 c.  $\frac{9x^7}{y}$   
 d.  $9x^7y$

Simplify the radical expression by rationalizing the denominator.

12.  $\frac{3}{\sqrt{11}}$   
 a.  $3\sqrt{11}$   
 b.  $\frac{3\sqrt{11}}{11}$   
 c.  $11\sqrt{3}$   
 d.  $\frac{\sqrt{121}}{11}$

Simplify the expression.

13.  $5\sqrt{2} + \sqrt{18}$   
 a.  $8\sqrt{2}$   
 b.  $6\sqrt{18}$   
 c.  $14\sqrt{2}$   
 d.  $8\sqrt{18}$

14.  $7\sqrt{7} - 2\sqrt{28}$   
 a.  $3\sqrt{28}$   
 b.  $-\sqrt{7}$   
 c.  $5\sqrt{28}$   
 d.  $3\sqrt{7}$



d. no solution

Match the function with its graph.

22.  $y = \sqrt{x} + 3$

a.

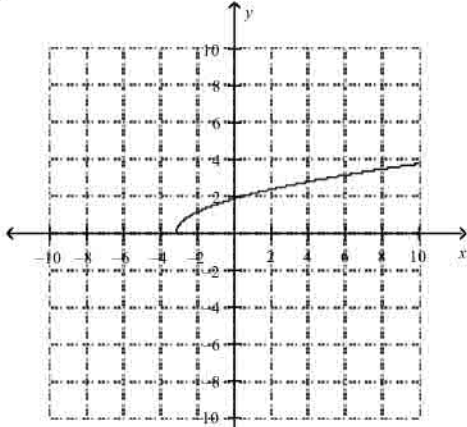

c.

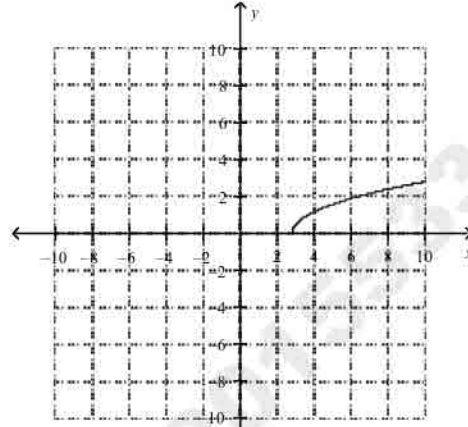

b.

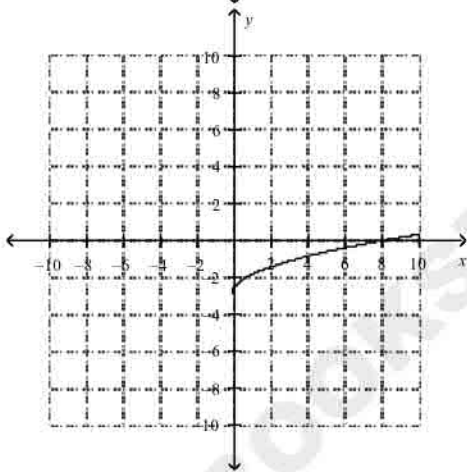

d.

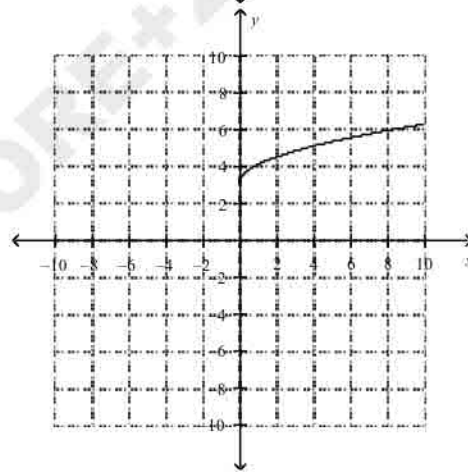

23.  $y = \sqrt{x} - 3$

a.

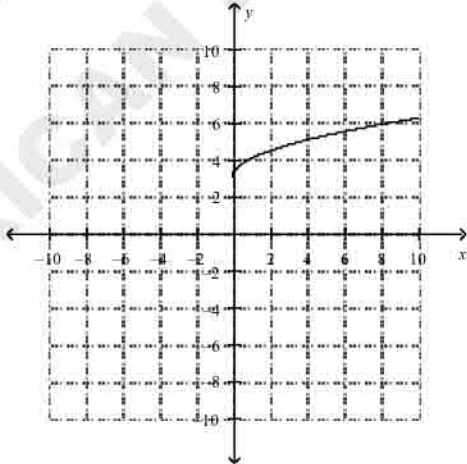

c.

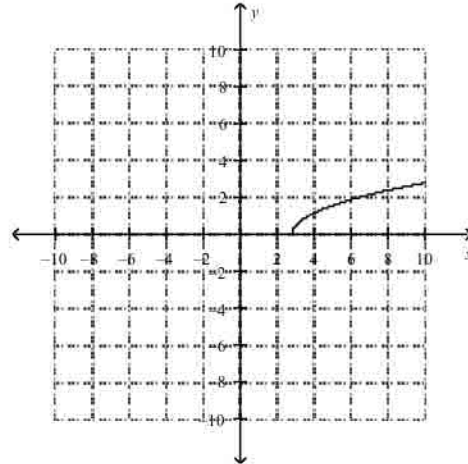

b.

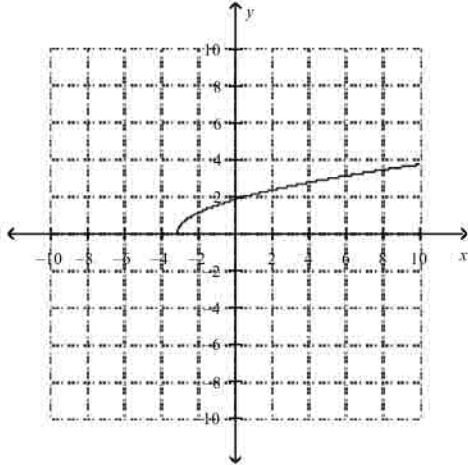

d.

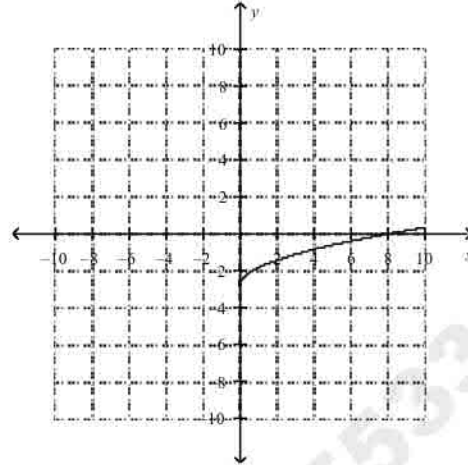

24.  $y = \sqrt{x+4}$

a.

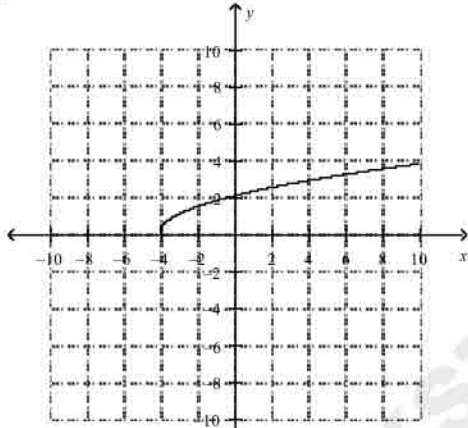

c.

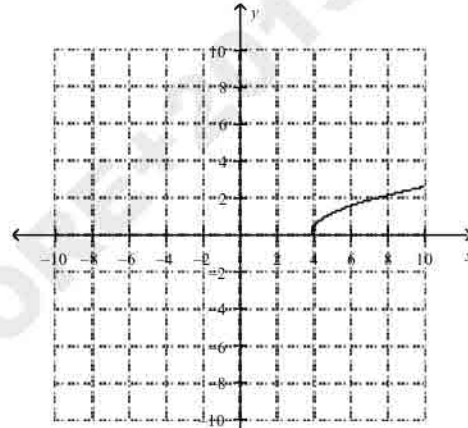

b.

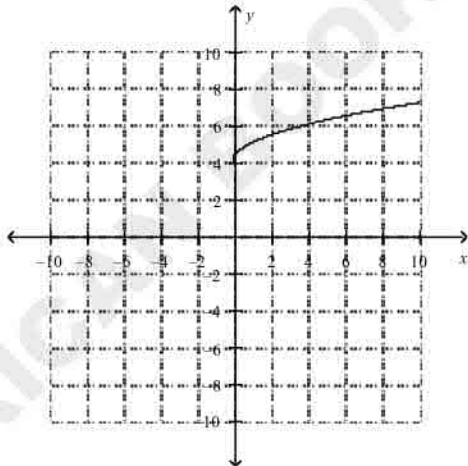

d.

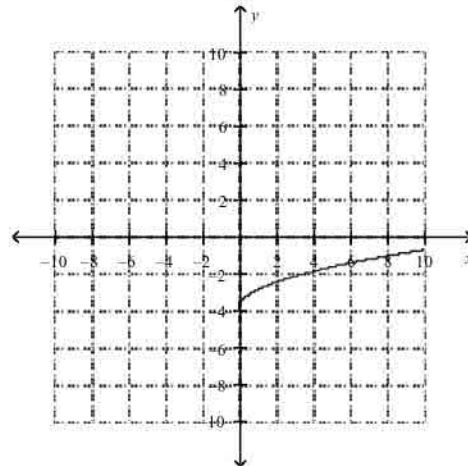

25.  $y = \sqrt{x-2}$

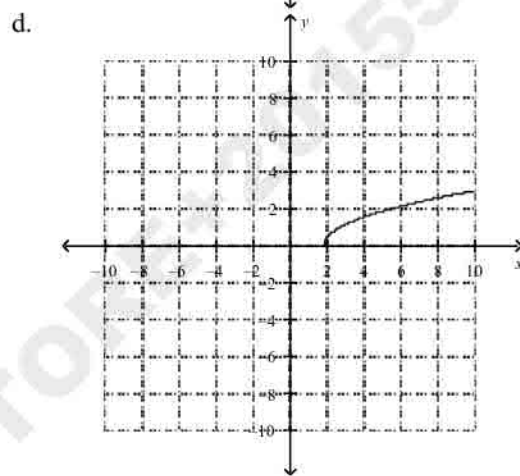
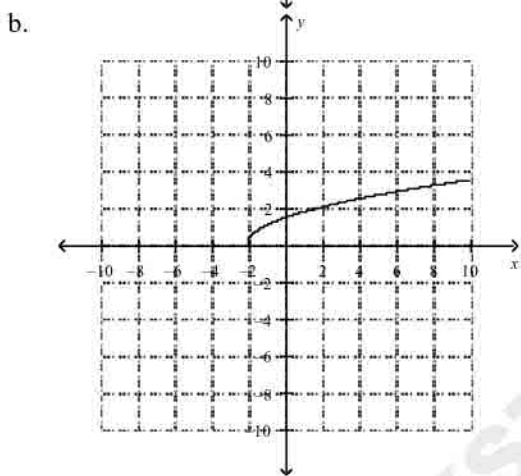
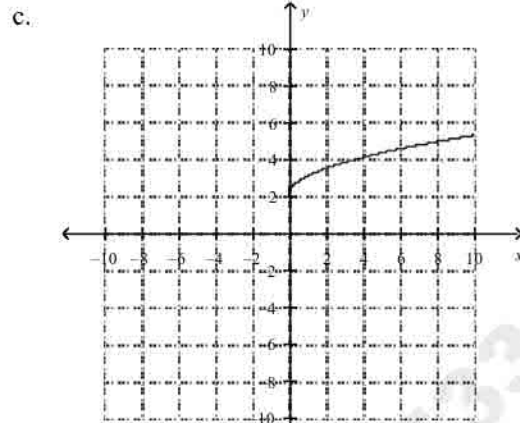
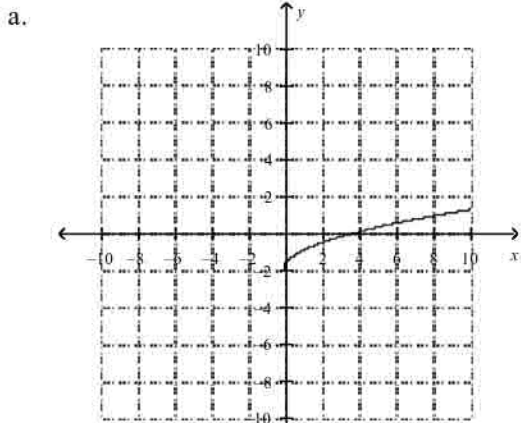

26. What is  $\sin A$  for the triangle shown?

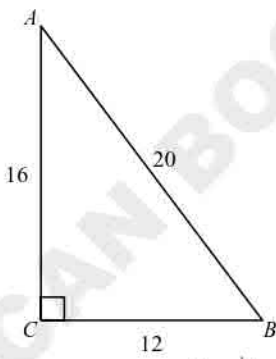

a.  $\frac{3}{4}$

b.  $\frac{3}{5}$

c.  $\frac{5}{3}$

d.  $\frac{4}{5}$

27. What is  $\cos A$  for the triangle shown?

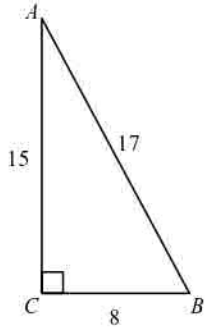

- a.  $\frac{8}{17}$       b.  $\frac{15}{17}$       c.  $\frac{8}{15}$       d.  $\frac{17}{8}$

28. What is  $\tan A$  for the triangle shown?

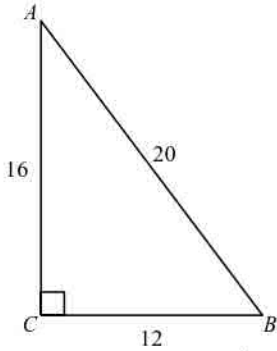

- a.  $\frac{4}{5}$       b.  $\frac{3}{4}$       c.  $\frac{5}{3}$       d.  $\frac{3}{5}$

Find the value of  $x$  to the nearest tenth.

29.

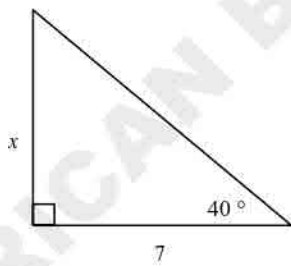

- a. 5.4      b. 5.9      c. -7.8      d. 4.5

30.

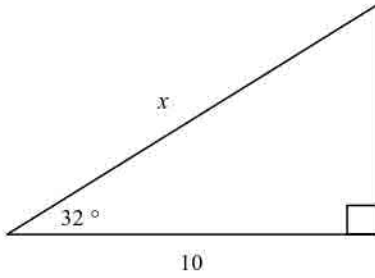

- a. 11.8                      b. 6.2                      c. 16                      d. 12

31. What is the measure of angle  $A$  in the triangle below?

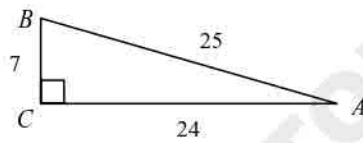

- a.  $73.7^\circ$                       b.  $16.3^\circ$                       c.  $25.2^\circ$                       d.  $90^\circ$

32. What is the measure of angle  $B$  in the triangle below?

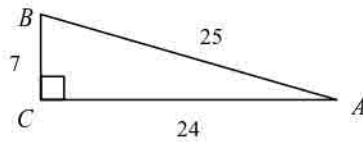

- a.  $73.7^\circ$                       b.  $90^\circ$                       c.  $25.2^\circ$                       d.  $16.3^\circ$

**Simplify the rational expression. State any excluded values.**

33.  $\frac{3x-6}{x-2}$
- a.  $\frac{3}{-2}$
- b. 6; where  $x \neq 3$
- c. 3; where  $x \neq 2$
- d.  $x$
34.  $\frac{2x-4}{2x+8}$
- a.  $\frac{x-2}{x+4}$ ; where  $x \neq -4$
- b.  $2\left(\frac{x+2}{x-4}\right)$ ; where  $x \neq 4$
- c.  $\frac{x+4}{x-2}$ ; where  $x \neq 2$
- d.  $\frac{x-2}{2x+8}$ ; where  $x \neq -4$
35.  $\frac{-14x^3}{x^3-3x^4}$
- a.  $\frac{-14x}{1-3x}$ ; where  $x \neq \frac{1}{3}$
- b.  $\frac{-14}{3x-1}$ ; where  $x \neq \frac{1}{3}, 0$
- c.  $\frac{1-3x}{-14x}$ ; where  $x \neq 0$
- d.  $\frac{-14}{1-3x}$ ; where  $x \neq \frac{1}{3}, 0$
36.  $\frac{x-2}{x^2+3x-10}$
- a.  $x^2$
- b.  $x+5$ ; where  $x \neq -5$
- c.  $\frac{1}{x^2}$ ; where  $x \neq -2$
- d.  $\frac{1}{x+5}$ ; where  $x \neq -5, 2$
37.  $\frac{x^2-12x+35}{x^2-3x-10}$
- a.  $\frac{x-5}{x-2}$ ; where  $x \neq 2$
- b.  $\frac{x+7}{x-2}$ ; where  $x \neq 2$
- c.  $\frac{x-7}{x+2}$ ; where  $x \neq -2, 5$
- d.  $\frac{x-7}{x-5}$  where  $x \neq 5$
38.  $\frac{x^2-3x-10}{-2-x}$
- a.  $-x+2$ ; where  $x \neq -5$
- b.  $x+2$ ; where  $x \neq 5$
- c.  $-x+5$ ; where  $x \neq -2$
- d.  $x+5$ ; where  $x \neq 2$
39. Suppose that a sphere with radius  $5a$  has the same volume as a cone of radius  $3a$ . What is the height of the cone? Give your answer in terms of  $a$ . Use the formulas  $V = \frac{4}{3}\pi r^3$  and  $V = \frac{1}{3}\pi r^2 h$  for the volumes of a sphere and cone respectively.
- a.  $\frac{9}{500}a^2$
- b.  $\frac{500}{9}a^2$
- c.  $\frac{9}{500}a^2$
- d.  $\frac{500}{9}a$
40. Suppose that a sphere with radius  $5a$  has the same volume as a cylinder of radius  $2a$ . What is the height of the cylinder? Give your answer in terms of  $a$ . Use the formulas  $V = \frac{4}{3}\pi r^3$  and  $V = \pi r^2 h$  for the volumes of a sphere and cylinder respectively.

a.  $\sqrt[3]{125a^2}$

b.  $\sqrt[3]{125^a}$

c.  $\sqrt[3]{125} a$

d.  $\sqrt[3]{125} a^2$

**Multiply.**

41.  $\frac{y^2 - 16}{2y} \cdot \frac{5y}{y - 4}$

a.  $\frac{5(y + 4)}{2}$

b.  $\frac{5(y - 4)}{2}$

c.  $\frac{y + 4}{2}$

d.  $\frac{(y - 4)}{2}$

42.  $\frac{k + 3}{4k - 2} \cdot (12k^2 - 3)$

a.  $\frac{3(k + 3)}{2}$

b.  $\frac{3(k + 3)(2k - 1)}{2}$

c.  $\frac{3(k + 3)(2k + 1)}{2}$

d.  $3(k + 3)(2k + 1)$

**Divide.**

43.  $\frac{s^2 + 5s}{s^2 + 9s + 20} \div \frac{s - 3}{s + 4}$

a.  $\frac{s + 5}{s - 3}$

b.  $\frac{s - 3}{s}$

c.  $\frac{s}{s - 3}$

d.  $\frac{s + 5}{s^2 - 3s}$

44.  $\frac{x^2 + 2x + 1}{x - 2} \div \frac{x^2 - 1}{x^2 - 4}$

a.  $\frac{(x + 1)(x + 2)}{x - 1}$

b.  $\frac{(x - 1)(x - 2)}{x + 1}$

c.  $\frac{(x - 1)(x + 2)}{x + 1}$

d.  $\frac{(x + 1)(x - 2)}{x - 1}$

45.  $(14m^9 - 4m^8 + 8m^6) \div 2m^3$

a.  $7m^6 - 4m^8 + 8m^3$

b.  $7m^9 - 2m^8 + 4m^6$

c.  $7m^6 - 2m^5 + 4m^3$

d.  $7m^6 - 2m^5 + 8m^6$

46.  $(x^2 - 9x + 25) \div (x - 5)$

a.  $x - 9 - \frac{25}{x - 5}$

b.  $x - 4 - \frac{5}{x - 5}$

c.  $x - 4 + \frac{5}{x - 5}$

d.  $x - 9 - 5$

47.  $(x^3 - 11x - 6) \div (x + 3)$

a.  $-x^2 + 3x - 2$

b.  $x^2 - 3x - 2$

c.  $-x^2 - 3x + 2$

d.  $x^2 + 3x + 2$

48. The width  $w$  of a rectangular swimming pool is  $2x + 2$ . The area  $A$  of the pool is  $12x^3 - 26x - 14$ . What is an expression for the length of the pool?
- a.  $6x^2 - 6x + 7$                       c.  $6x^2 + 6x - 7$   
 b.  $6x^2 - 6x - 7$                       d.  $6x^2 + 6x + 7$

**Add or subtract.**

49.  $\frac{8}{x+3} - \frac{3}{x-2}$
- a.  $\frac{5x}{(x+3)(x-2)}$                       c.  $\frac{5x+25}{(x+3)(x-2)}$   
 b.  $\frac{5x-25}{(x+3)(x-2)}$                       d.  $\frac{-5x-25}{(x+3)(x-2)}$

50.  $\frac{5}{x-4} + \frac{3}{x+4}$
- a.  $\frac{8x-8}{(x-4)(x+4)}$                       c.  $\frac{8x}{(x-4)(x+4)}$   
 b.  $\frac{-8x+8}{(x-4)(x+4)}$                       d.  $\frac{8x+8}{(x-4)(x+4)}$

51.  $\frac{5}{x-1} - \frac{-1}{x+4}$
- a.  $\frac{6}{x-5}$                                       c.  $\frac{6x+19}{(x-1)(x+4)}$   
 b.  $\frac{19}{(x-1)(x+4)}$                       d.  $\frac{6}{(x-1)(x+4)}$

52. What is the graph of  $y = \frac{3}{x}$ ?

a.

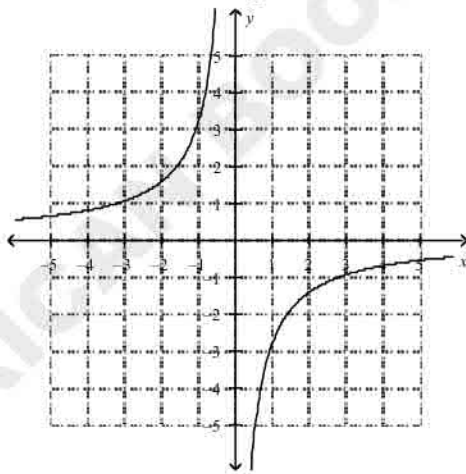

c.

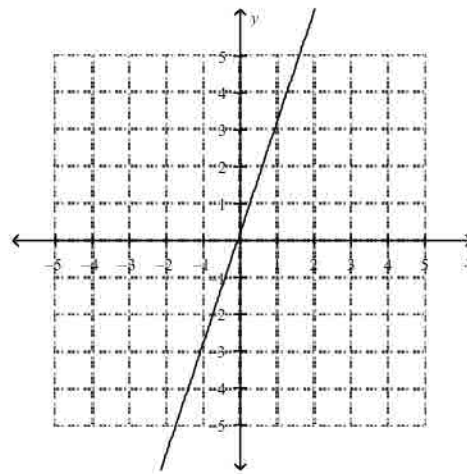

b.

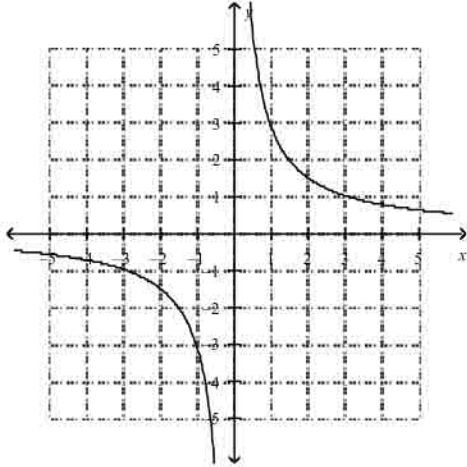

d.

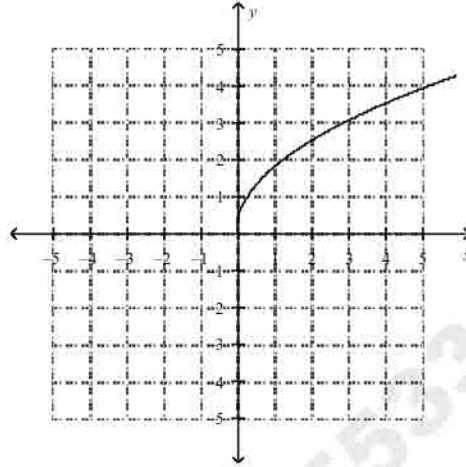

53. What is the graph of  $y = -\frac{2}{x}$ ?

a.

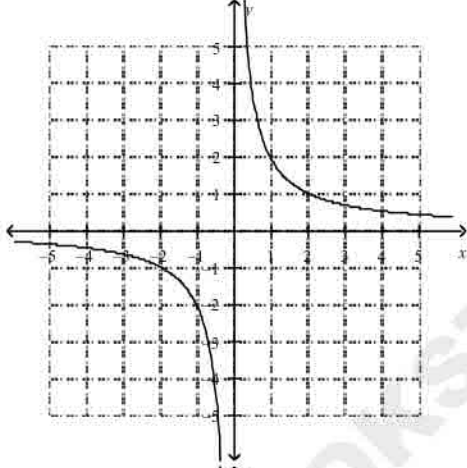

c.

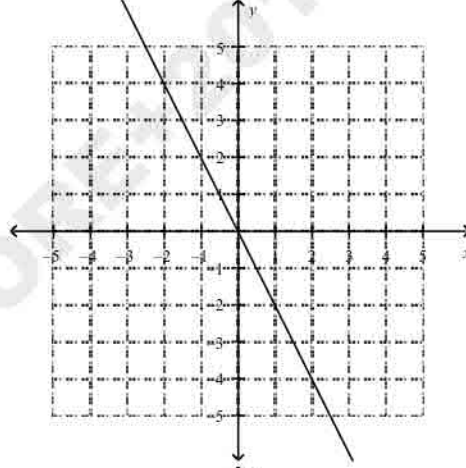

b.

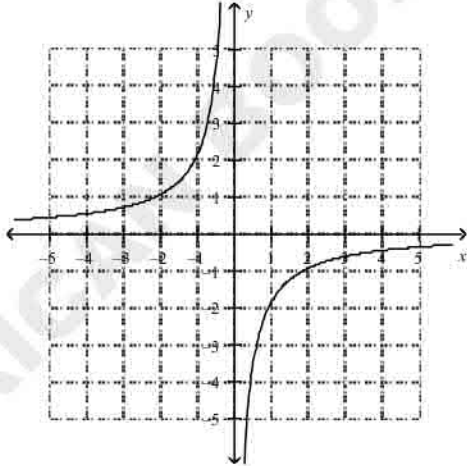

d.

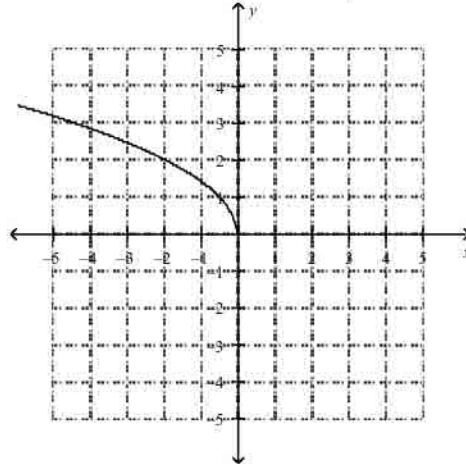

Do the data in the table represent a direct variation or an inverse variation? Write an equation to model the data in the table.

54.

$x$	5	10	15	20
-----	---	----	----	----

$y$	50	100	150	200
-----	----	-----	-----	-----

- a. inverse variation;  $xy = 10$   
 b. direct variation;  $y = 10x$

- c. direct variation;  $y = \frac{1}{10}x$   
 d. inverse variation;  $xy = \frac{1}{10}$

55.

$x$	2	4	8	12
$y$	4	2	1	$\frac{2}{3}$

- a. direct variation;  $y = \frac{8}{x}$   
 b. inverse variation;  $\frac{y}{x} = 8$

- c. direct variation;  $y = 8x$   
 d. inverse variation;  $xy = 8$

Graph the function and identify the vertical asymptote.

56.  $y = \frac{1}{x-1} - 3$

a.

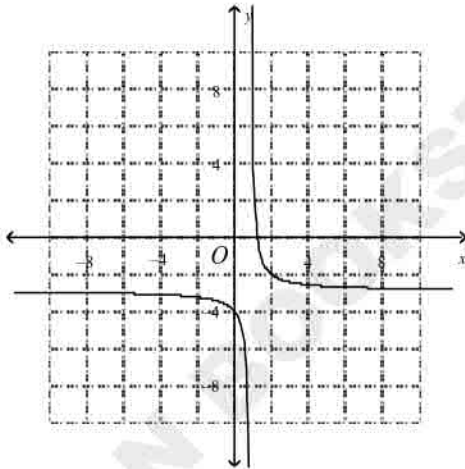

$x = 1$

c.

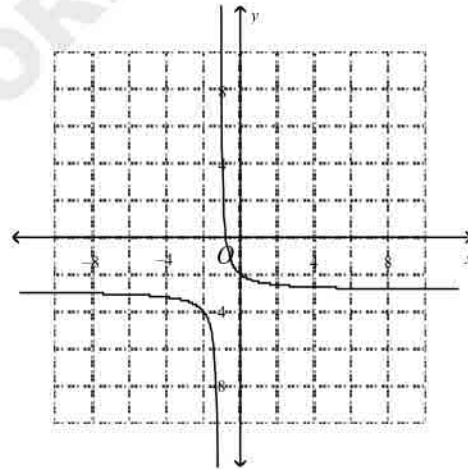

$y = -1$

$y$

b.

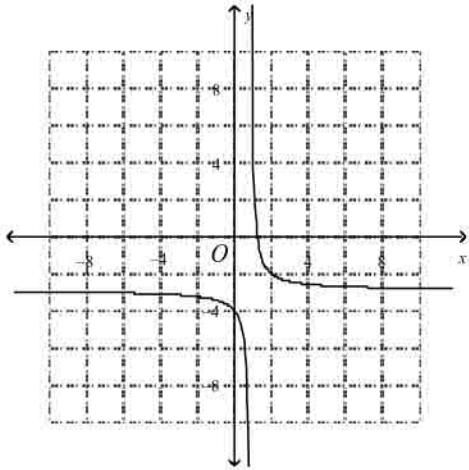

d.

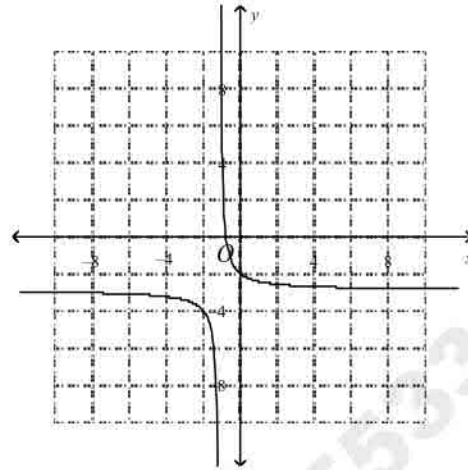

$y = 1$

$y$

$x = -1$

57.  $y = \frac{1}{x+1} - 2$

a.

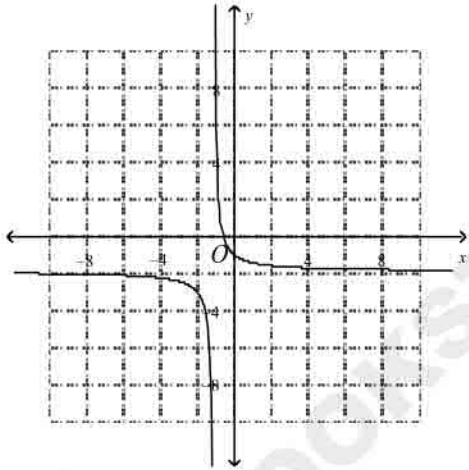

c.

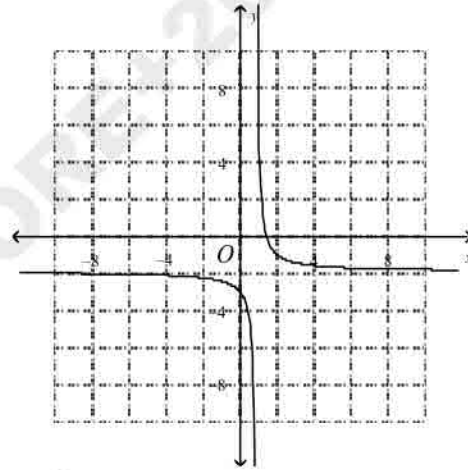

$x = -1$

$x = 1$

b.

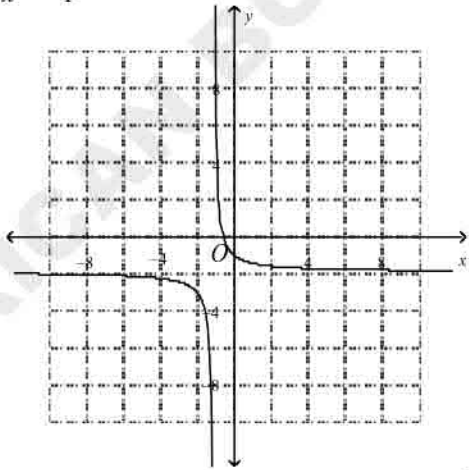

d.

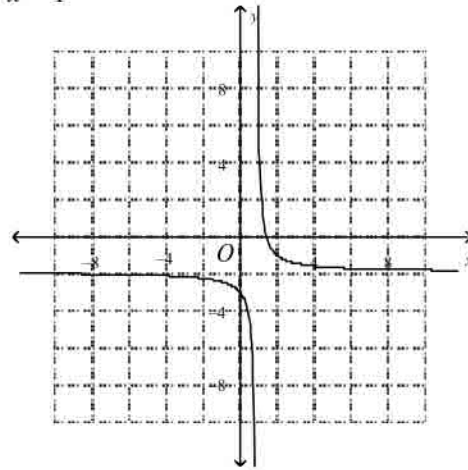

$y = -1$

$y$

$y = 1$

$y$

Identify the asymptotes of the graph.

58.  $y = \frac{1}{x+1} - 2$

a.

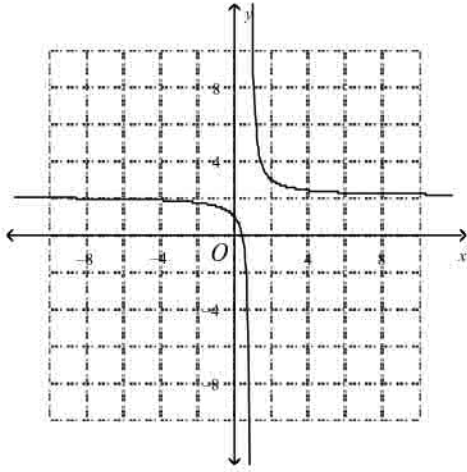

c.

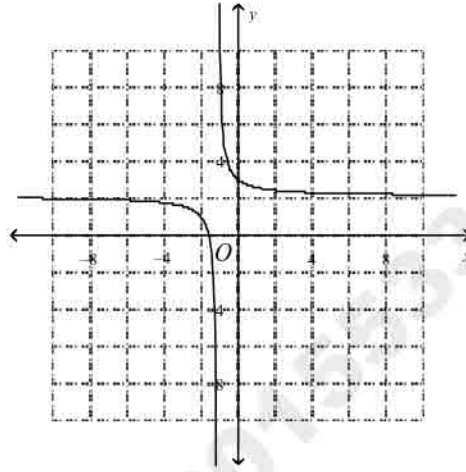

$x = 1, y = 2$

b.

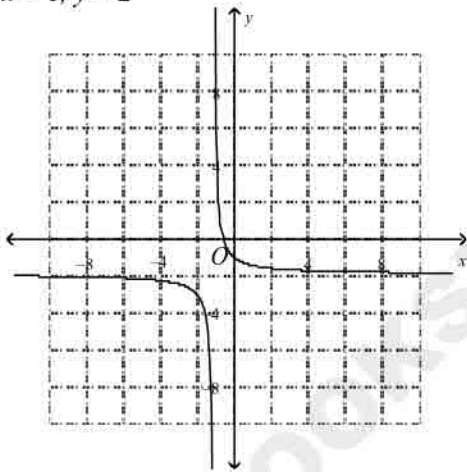

$x = -1, y = 2$

d.

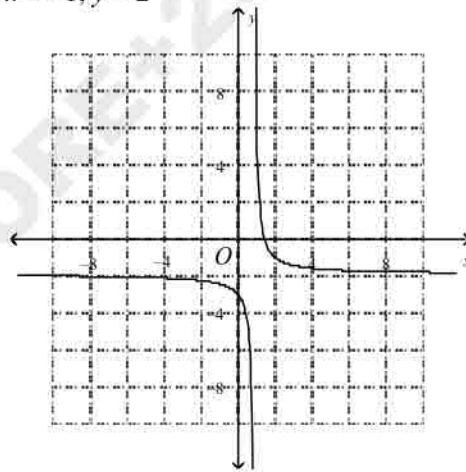

$x = -1, y = -2$

$x = 1, y = 2$

59.  $y = \frac{1}{x-2} - 4$

a.

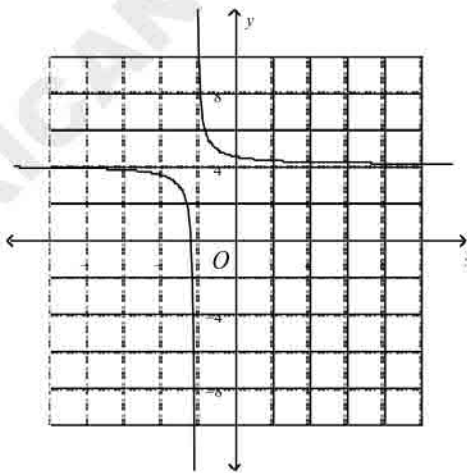

c.

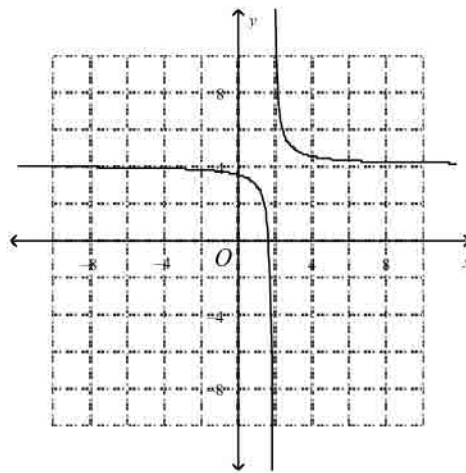

b.  $x = -2, y = 4$

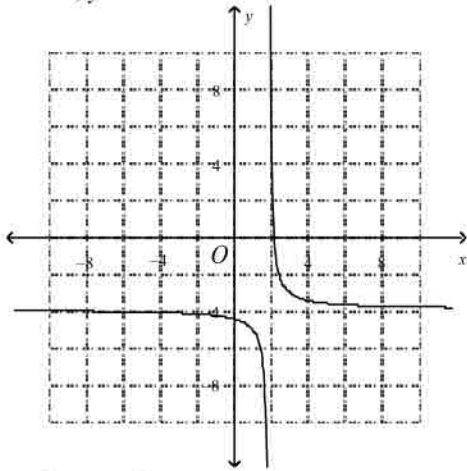

d.  $x = 2, y = 4$

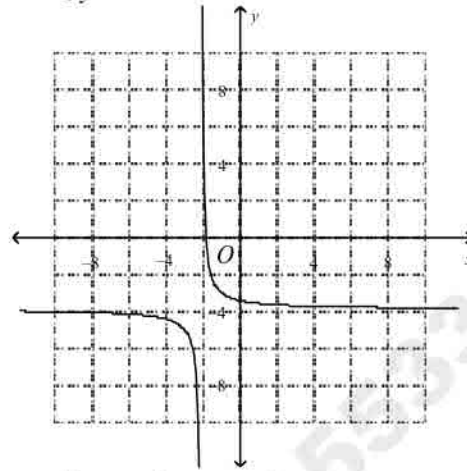

$x = 2, y = -4$

$x = -2, y = -4$

60. The number of hours a group of contestants spent preparing for a quiz show are listed below. What is a frequency table that represents the data?

60 25 86 56 45 48 90 75 30 67 90 36 80 15 32 65 61

a.

Hours	Frequency
0 - 9	0
10 - 19	1
20 - 29	1
30 - 39	3
40 - 49	2
50 - 59	1
60 - 69	4
70 - 79	1
80 - 89	2
90 - 99	2

c.

Hours	Frequency
0 - 9	0
10 - 19	1
20 - 29	2
30 - 39	1
40 - 49	2
50 - 59	1
60 - 69	4
70 - 79	1
80 - 89	1
90 - 99	1

b.

Hours	Frequency
0 – 9	4
10 – 19	1
20 – 29	1
30 – 39	2
40 – 49	3
50 – 59	4
60 – 69	1
70 – 79	1
80 – 89	1
90 – 99	1

d.

Hours	Frequency
0 – 9	1
10 – 19	2
20 – 29	1
30 – 39	2
40 – 49	2
50 – 59	3
60 – 69	3
70 – 79	1
80 – 89	0
90 – 99	2

61. The data below shows the average number of text messages a group of students send per day. What is a histogram that represents the data?

20 5 8 22 10 1 7 15 16 12 15 6 13 8

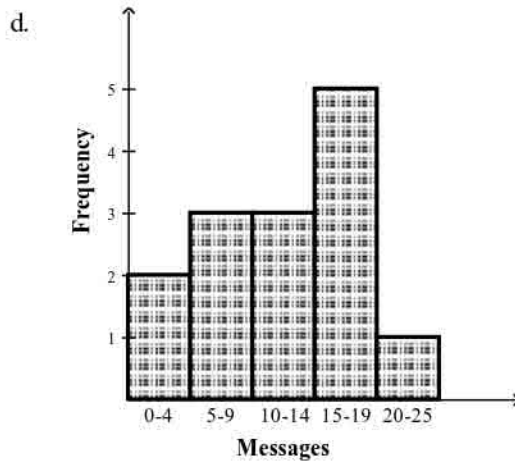
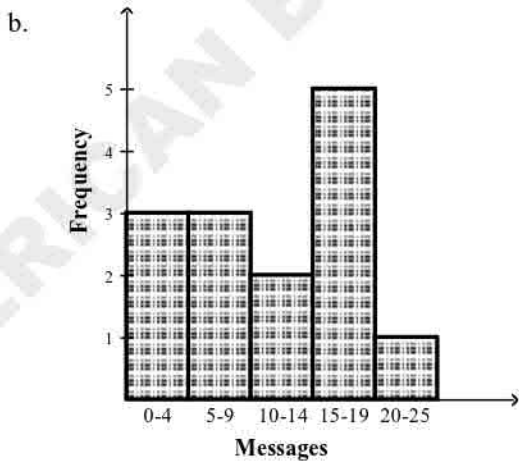
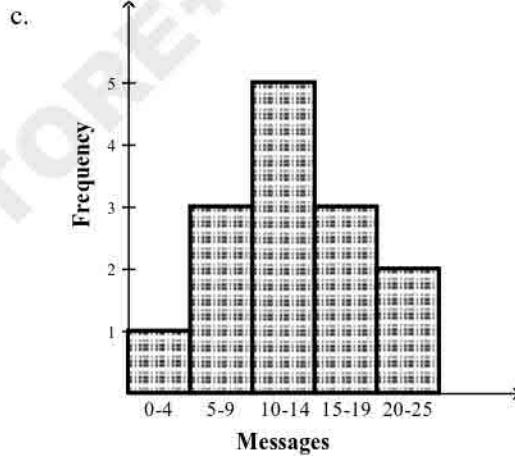
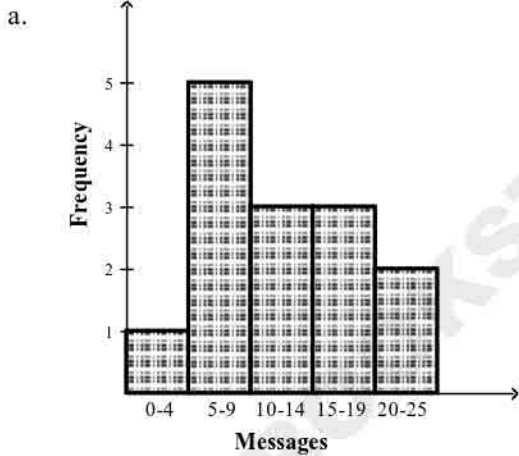

62. The data below show the number of games won by a football team in each of the last 15 seasons. What is a histogram that represents the data?

3 4 8 12 7 2 1 15 16 6 10 13 4 1 5

a.

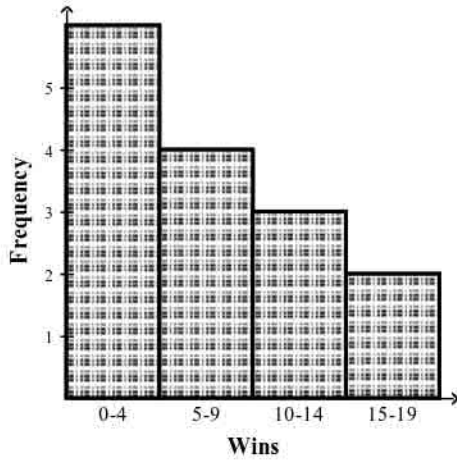

c.

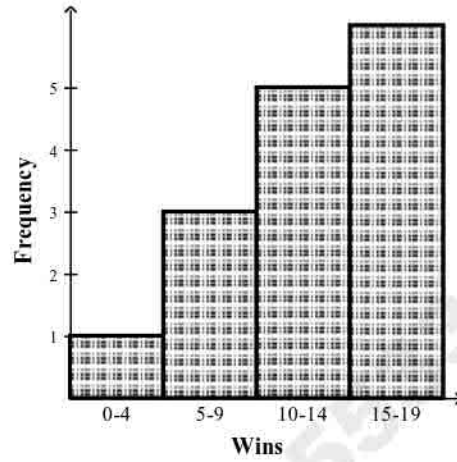

b.

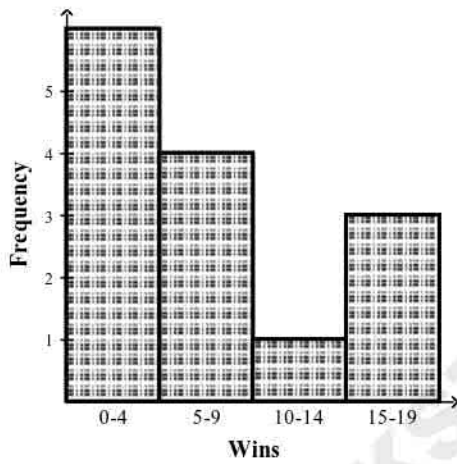

d.

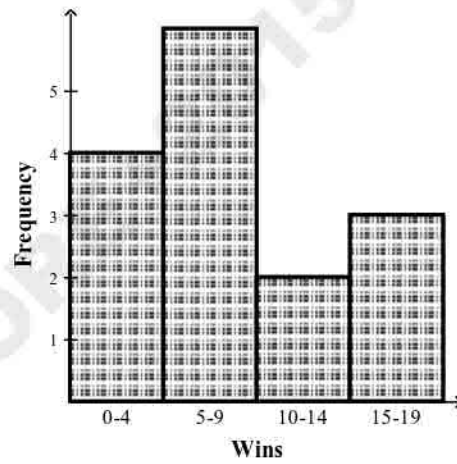

63. The data below shows the number of kilowatt hours of electricity used by the tenants of a small apartment building in a given month. What is a cumulative frequency table that represents the data?

80 85 86 90 96 75 66 70  
99 65 70 99 70 73 64 92  
72 81 88 91 93 69 77 82

a.

Kilowatt Hours	Frequency	Cumulative Frequency
60 – 69	7	7
70 – 79	4	11
80 – 89	7	18
90 – 99	6	24

b.

Kilowatt Hours	Frequency	Cumulative Frequency
60 – 69	4	4
70 – 79	7	11
80 – 89	6	17
90 – 99	7	24

c.

Kilowatt Hours	Frequency	Cumulative Frequency
60 – 69	7	24
70 – 79	4	24
80 – 89	5	24
90 – 99	6	24

d.

Kilowatt Hours	Frequency	Cumulative Frequency
60 – 69	4	4
70 – 79	6	10
80 – 89	7	17
90 – 99	7	24

Find the mean, median, and mode of the data set. Round to the nearest tenth.

64. 15, 1, 4, 4, 8, 7, 15, 4, 15, 4, 5  
 a. mean = 6.8, median = 5, mode = 4  
 b. mean = 7.5, median = 5, mode = 4  
 c. mean = 7.5, median = 8, mode = 4  
 d. mean = 6.8, median = 5, mode = 8
65. Find  $x$  if the average of 20, 20, 19, 13, and  $x$  is 16.  
 a. 8  
 b. 9  
 c. 10  
 d. 6
66. The table shows the number of hours that a group of students spent studying for the SAT during their first week of preparation. The students each add 3 hours to their study times in the second week. What are the mean, median, mode, and range of times for the second week?

Student	Hours
Bob	20
James	10
Karen	10
Rosario	11
Antoine	13
Julio	17
Maria	15

- |  |  |
|--|--|
| a. mean = 13<br>median = 16<br>mode = 16.7<br>range = 10   | c. mean = 16.7<br>median = 16<br>mode = 13<br>range = 10   |
| b. mean = 16<br>median = 16.7<br>mode = 13<br>range = -0.7 | d. mean = 16.7<br>median = 16<br>mode = 13<br>range = -0.7 |

What are the minimum, first quartile, median, third quartile, and maximum of the data set?

67. 9, 20, 4, 18, 4, 18, 20, 9
- minimum 4; first quartile 10; median 16.25; third quartile 19.5; maximum 20
  - minimum 4; first quartile 6.5; median 13.5; third quartile 19.5; maximum 20
  - minimum 4; first quartile 6.5; median 13.5; third quartile 19; maximum 20
  - minimum 4; first quartile 5.25; median 16.25; third quartile 19; maximum 20

Make a box-and-whisker plot of the data.

68. 21, 27, 22, 22, 25, 14, 16, 10
- - 
  - 
  -

69. The two box-and-whisker plots below show the times in seconds for two teams in a 100 m dash. What do the interquartile ranges tell you about the two teams?

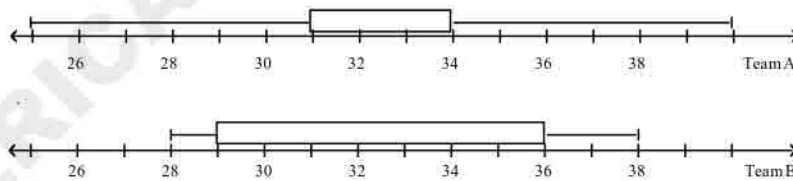

- Team A has more consistent times
  - Team B has more consistent times
  - Overall team A is faster than team B
  - Overall team B is faster than team A
70. You roll a standard number cube. Find  $P(\text{number greater than 5})$

ALL QUESTIONS HAVE BEEN COLLECTED FROM PEARSON

a.  $\frac{2}{5}$

b.  $\frac{5}{6}$

c.  $\frac{1}{3}$

d.  $\frac{1}{6}$

\_\_\_\_ 71. You have the numbers 1–25 written on slips of paper. If you choose one slip at random, what is the probability that you will select a number which is divisible by 4?

a.  $\frac{1}{5}$

b.  $\frac{6}{25}$

c.  $\frac{4}{25}$

d.  $\frac{2}{3}$

\_\_\_\_ 72. You have the numbers 1–24 written on slips of paper. If you choose one slip at random, what is the probability that you will NOT select a number which is divisible by 3?

a.  $\frac{3}{8}$

b.  $\frac{1}{3}$

c.  $\frac{5}{8}$

d.  $\frac{2}{3}$

AMERICAN BOOKSTORE+201553389184

**Answer Section**

**MULTIPLE CHOICE**

1. ANS: B
2. ANS: B
3. ANS: A
4. ANS: A
5. ANS: C
6. ANS: C
7. ANS: C
8. ANS: B
9. ANS: B
10. ANS: C
11. ANS: B
12. ANS: B
13. ANS: A
14. ANS: D
15. ANS: C
16. ANS: B
17. ANS: B
18. ANS: A
19. ANS: C
20. ANS: C
21. ANS: D
22. ANS: D
23. ANS: D
24. ANS: A
25. ANS: D
26. ANS: B
27. ANS: B
28. ANS: B
29. ANS: B
30. ANS: A
31. ANS: B
32. ANS: A
33. ANS: C
34. ANS: A
35. ANS: D
36. ANS: D
37. ANS: C
38. ANS: C
39. ANS: D
40. ANS: C

ALL QUESTIONS HAVE BEEN COLLECTED FROM PEARSON

- 41. ANS: A
- 42. ANS: C
- 43. ANS: C
- 44. ANS: A
- 45. ANS: C
- 46. ANS: C
- 47. ANS: B
- 48. ANS: B
- 49. ANS: B
- 50. ANS: D
- 51. ANS: C
- 52. ANS: B
- 53. ANS: B
- 54. ANS: B
- 55. ANS: D
- 56. ANS: A
- 57. ANS: A
- 58. ANS: B
- 59. ANS: B
- 60. ANS: A
- 61. ANS: A
- 62. ANS: A
- 63. ANS: B
- 64. ANS: B
- 65. ANS: A
- 66. ANS: C
- 67. ANS: C
- 68. ANS: C
- 69. ANS: A
- 70. ANS: D
- 71. ANS: B
- 72. ANS: D

AMERICAN BOOKSTORE+201553389184



**Multiple Choice**

Identify the choice that best completes the statement or answers the question.

**What is an algebraic expression for the word phrase?**

1. 6 times the difference of  $b$  and  $p$   
 a.  $6b - p$                       b.  $6(b - p)$                       c.  $6 - bp$                       d.  $6bp$

**What word phrase can you use to represent the algebraic expression?**

2.  $5x + 2$   
 a. five times the sum of a number  $x$  and two  
 b. two times the sum of a number  $x$  and five  
 c. a number  $x$  times the sum of five and two  
 d. the sum of five times a number  $x$  and two

**What is the simplified form of each expression?**

3.  $(0.1)^4$   
 a. 1.1487    c. 0.001  
 b. 0.0001    d. 0.00001

4.  $\left(\frac{4}{7}\right)^3$   
 a. 343    c. 21952  
    64  
 b. 64    d. 407  
    343

**What is the simplified form of each expression?**

5.  $5(14 - 2)^2 + 2$   
 a. 60    b. 30    c. 72    d. 360

6.  $13\left[6^2 + (5^2 - 4^2) + 9\right]$   
 a. 585    b. 169    c. 26    d. 181

**What is the simplified form of each expression?**

7.  $\sqrt{\frac{25}{100}}$   
 a.  $\frac{1}{20}$     b.  $\frac{1}{2}$     c. 20    d.  $\frac{5}{2}$

8.  $\sqrt{\frac{1}{169}}$

- a.  $\frac{1}{338}$                       b.  $\frac{1}{13}$                       c. 13                      d.  $\frac{2}{169}$

What is the simplified form of each expression?

9.  $-\sqrt{196}$   
 a. 98                      b. -14                      c. 14                      d. 392

10. What is the value of  $\frac{x}{y}$  when  $x = \frac{9}{4}$  and  $y = \frac{3}{5}$ ?  
 a.  $\frac{15}{4}$                       c.  $\frac{27}{20}$   
 b.  $\frac{4}{3}$                       d.  $\frac{15}{4}$

What is the simplified form of each expression?

11.  $1.7m^2 + 6.5n - 4n + 2.5m^2 - n$   
 a.  $4.2m^2 + 1.5n$                       c.  $1.5m^2 - 4.2n$   
 b.  $4.2m^2 - 1.5n$                       d.  $1.5m^2 + 4.2n$
12.  $2.5m^2 + 7.8n - 3.2n + 5.3m^2 - 5.9n$   
 a.  $7.8m^2 - 1.3n$                       c.  $7.8m^2 + 10.5n$   
 b.  $-2.8m^2 - 1.3n$                       d.  $-2.8m^2 + 10.5n$

What sum or difference is equivalent to the expression?

13.  $\frac{3x+2}{8}$   
 a.  $\frac{3}{8}x + \frac{1}{4}$                       b.  $\frac{1}{4}x + \frac{3}{8}$                       c.  $\frac{5}{8}x$                       d.  $\frac{1}{4}$
14.  $\frac{3x-2}{9}$   
 a.  $\frac{1}{3}x - \frac{2}{9}$                       b.  $\frac{2}{9}x - \frac{1}{3}$                       c.  $\frac{1}{9}x$                       d.  $\frac{2}{9}$

What is the solution of the equation?

15.  $-2 = \frac{-5+z}{-2}$   
 a. -1                      b. 6                      c. 9                      d. -4
16.  $\frac{b-3}{-5} = -15$   
 a. 0                      b. 72                      c. 78                      d. 6

What is the solution of the equation?

17.  $2 = 6p - 8 - 5p$

- \_\_\_\_\_ 18.  $3x - 9 = 5x - 7$   
 a. -3                      b. 0                      c. -1                      d. 2
- \_\_\_\_\_ 19.  $5d - d - 2d + 8 = 3d = 0$   
 a. -5                      b.  $\frac{8}{5}$                       c.  $\frac{8}{3}$                       d. 8
- \_\_\_\_\_ 20.  $-6y + 14 + 4y = 32$   
 a. 18                      b. 1.8                      c. -9                      d. 9
- \_\_\_\_\_ 21. John and 2 friends are going out for pizza for lunch. They split one pizza and 3 large drinks. The pizza cost \$12.00. They spend a total of \$16.95. Find the cost of one large drink.  
 a. \$14.48                      b. \$1.65                      c. \$1.70                      d. \$2.48

**What is the solution of the equation?**

- \_\_\_\_\_ 22.  $3(y - 5) + 2 = 5$   
 a. 4                      b. 7                      c. -4                      d. 6
- \_\_\_\_\_ 23.  $70 = -7(-2 - 2z)$   
 a. 4                      b. -28                      c. -112                      d. 784
- \_\_\_\_\_ 24.  $\frac{3p}{5} + \frac{8}{5} = 1$   
 a. 15                      b. 2                      c. -10                      d. -1
- \_\_\_\_\_ 25.  $\frac{4p}{6} + 27 = 39$   
 a. 22                      b. 99                      c. 4                      d. 18
- \_\_\_\_\_ 26.  $2.4x + 2.6 = 17$   
 a. 6                      b. 4.9                      c. 8.2                      d. 7

**What is the solution of the equation?**

- \_\_\_\_\_ 27.  $6x - 3 = 5x - 5$   
 a. -4                      b. -2                      c. 0                      d. -1
- \_\_\_\_\_ 28.  $-4x - 9 = -5 - 6x$   
 a. 4                      b. 1                      c. -1                      d. 2

**What is the solution of the equation?**

- \_\_\_\_\_ 29.  $3p - 1 = 5(p - 1) - 2(7 - 2p)$   
 a. 3                      b. 0                      c. -9                      d. -10
- \_\_\_\_\_ 30.  $-6p + 7 = 3(2p - 3) - 4(-10 + 4p)$   
 a.  $p = 6$                       b.  $p = 5$                       c.  $p = 7$                       d.  $p = 12$
- \_\_\_\_\_ 31. What equation do you get when you solve  $a - q = a + sx$  for  $x$ ?  
 a.  $x = \frac{2a - q}{s}$                       c.  $x = -\frac{2a + q}{s}$   
 b.  $x = -\frac{s}{q}$                       d.  $x = -\frac{q}{s}$



43. A van travels 220 miles on 10 gallons of gas. Find how many gallons the van needs to travel 550 miles.
- 31 gallons of gas
  - 121 gallons of gas
  - 115 gallons of gas
  - 25 gallons of gas

In the diagram, the figures are similar. What is  $x$ ?

44.

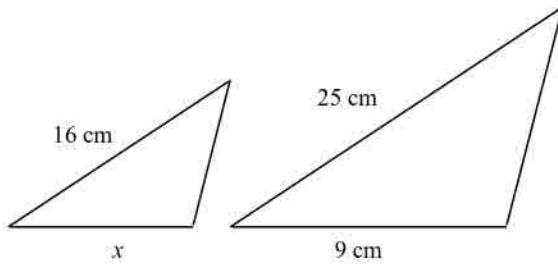

Drawing not to scale

- 18 cm
  - 11.9 cm
  - 14.1 cm
  - 5.8 cm
45. A tree casts a shadow 10 ft long. A boy standing next to the tree casts a shadow 2.5 ft long. The triangle shown for the tree and its shadow is similar to the triangle shown for the boy and his shadow. If the boy is 5 ft tall, how tall is the tree?

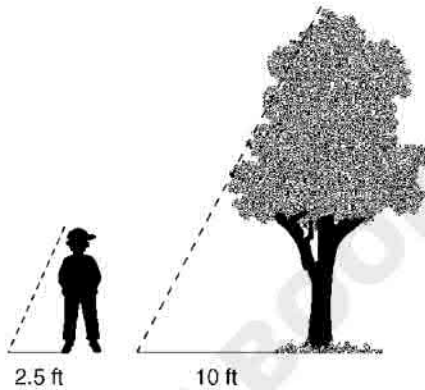

Drawing not to scale

- 18 ft
  - 12.5 ft
  - 15 ft
  - 20 ft
46. A building casts a shadow 10 ft long. A statue in front of the building casts a shadow 2.5 ft long. If the statue is 15 ft tall, how tall is the building?
- 36 ft
  - 25 ft
  - 30 ft
  - 60 ft
47. What percent of 140 is 112?
- 0.8%
  - 125%
  - 1.25%
  - 80%
48. What percent of 100 is 30?
- 30%
  - 333%
  - 3.33%
  - 0.3%
49. A dress that normally costs \$69.50 is on sale for 45% off. What is the sale price of the dress?



58.  $x \leq 5$

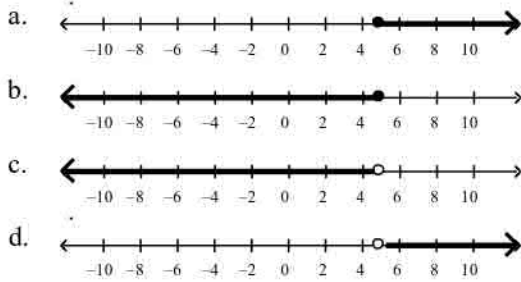

What inequality represents the graph?

59.

- a.  $x \leq -8$       b.  $x < -8$       c.  $x > -8$       d.  $x < 8$

What inequality describes the situation?

60. Let  $t$  = the amount Thomas earned. Thomas earned \$49 or more.

- a.  $t \leq 49$       b.  $t \geq 49$       c.  $t > 49$       d.  $t < 49$

61. Let  $n$  = the number. A number exceeds 45.

- a.  $n \leq 45$       b.  $n \geq 45$       c.  $n < 45$       d.  $n > 45$

What are the solutions of the inequality? Graph the solutions.

62.  $\frac{x}{5} \geq -2$

a.  $x \geq -7$

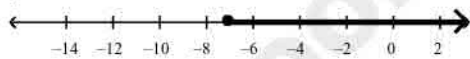

b.  $x \geq 7$

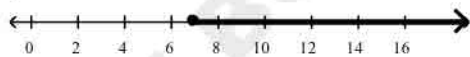

c.  $x \leq -10$

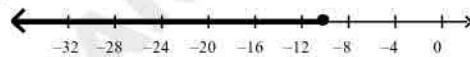

d.  $x \geq -10$

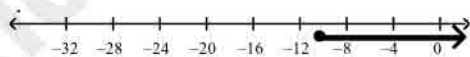

What are the solutions of the inequality? Graph and check the solutions.

63.  $-\frac{x}{4} \leq 2$

a.  $x \leq -8$

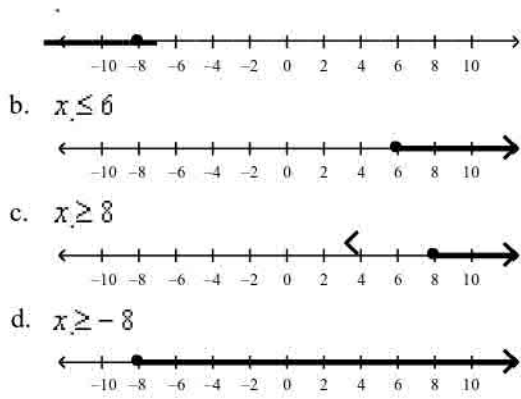

What are the solutions of the inequality? Graph the solutions.

64.  $-5x \geq -10$

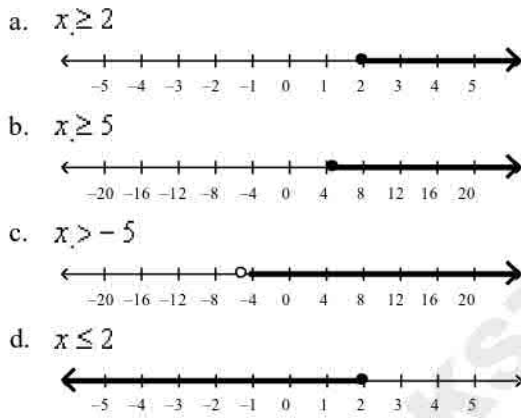

65.  $-12r < -24$

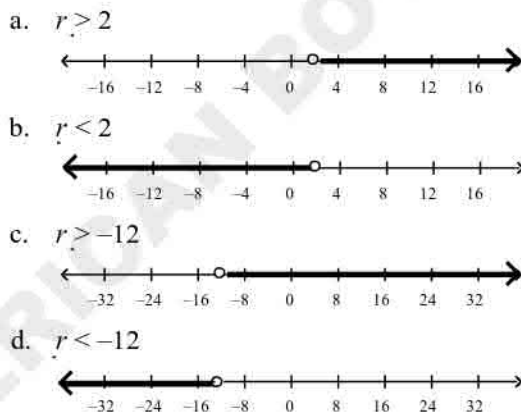

What are the solutions of the inequality? Check the solutions.

66.  $4x + 6 < -6$

a.  $x < -3$

b.  $x > -3$

c.  $x > -6$

d.  $x < +6$

What are the solutions of the inequality?

67.  $q + 12 - 2(q - 22) > 0$   
 a.  $q < -32$       b.  $q > -32$       c.  $q > 56$       d.  $q < 56$

What are the solutions of the inequality?

68.  $12 + 10w \geq 8(w + 12)$   
 a.  $w \geq -42$       b.  $w \geq 48$       c.  $w \geq 42$       d.  $w \geq 54$
69.  $12x - 3x + 11 > 4x - (17 - 9x)$   
 a.  $x > -7$       b.  $x < 7$       c.  $x < -\frac{14}{11}$       d.  $x > -\frac{14}{11}$

What are the solutions of the inequality?

70.  $-2(3x + 2) \geq -6x - 4$   
 a.  $x \geq 0$       c. all real numbers  
 b.  $x \leq 6$       d. no solution
71.  $10x - 10 - 7x \geq 3x - 2$   
 a.  $x \geq -8$       c. all real numbers  
 b.  $x \leq 8$       d. no solution

What are all the subsets of the set?

72.  $\{-1, 9\}$   
 a.  $\emptyset, \{-1\}, \{9\}$       c.  $\emptyset, \{-1\}, \{9\}, \{-1, 9\}$   
 b.  $\{-1\}, \{9\}, \{-1, 9\}$       d.  $\{-1\}, \{9\}$

What compound inequality represents the phrase? Graph the solutions.

73. all real numbers that are greater than  $-8$  and less than  $8$

a.  $-8 < x < 8$



b.  $-8 < x < 8$



c.  $-8 < x \leq 8$

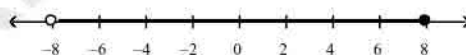

d.  $-8 \leq x \leq 8$

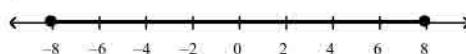

74. all real numbers  $w$  that are less than  $-7$  or greater than  $14$   
 a.  $-7 < w < 14$

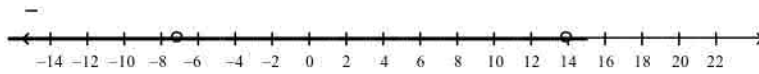

b.  $w < 14$  or  $w > -7$



c.  $w < -7$  or  $w > 14$

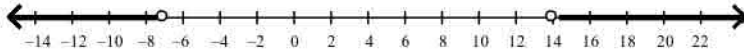

d.  $w < -7$  or  $w \geq 14$

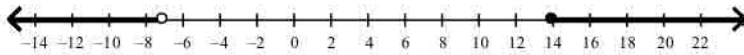

What are the solutions of the compound inequality? Graph the solutions.

75.  $-2 \leq 2x - 4 < 8$

a.  $1 \leq x < 2$

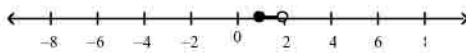

b.  $3 \leq x < 8$

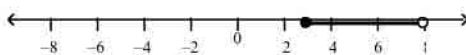

c.  $1 \leq x < 6$

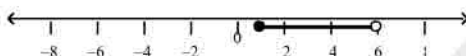

d.  $0 \leq x < 2$



76.  $\frac{-2}{4} < x < \frac{10}{12} \leq 6$

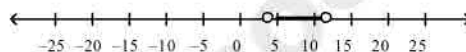

b.  $-3 < x < -1$

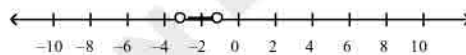

c.  $-16 < x < -8$

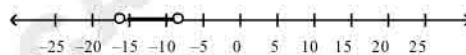

d.  $2 < x < 4$

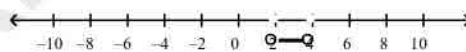

77. A student scored 83 and 91 on her first two quizzes. Write and solve a compound inequality to find the possible values for a third quiz score that would give her an average between 85 and 90, inclusive.

a.  $85 \leq \frac{83 + 91 + n}{3} \leq 90; 81 \leq n \leq 96$

- b.  $85 \leq \frac{83 + 91}{2} + n \leq 90; -2 \leq n \leq 3$   
 c.  $90 \leq \frac{83 + 91 + n}{3} \leq 85; 96 \leq n \leq 81$   
 d.  $83 \leq \frac{85 + 91 + n}{3} \leq 90; 73 \leq n \leq 94$

What are the solutions of the compound inequality? Graph the solutions.

78.  $2x - 2 < -12$  or  $2x + 3 > 7$

a.  $x < -5$  or  $x > 2$

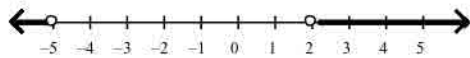

b.  $x < -5$  or  $x > 5$

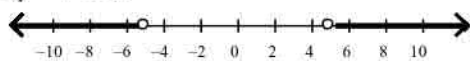

c.  $x < -7$  or  $x > 5$

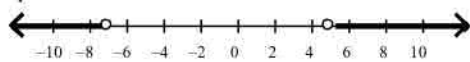

d.  $x < -12$  or  $x > 2$

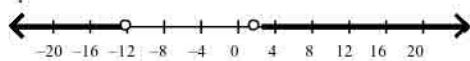

79. What is the graph of  $(-8, 2]$ ?

a.



b.

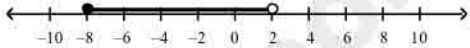

c.



d.

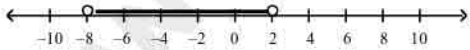

80. How do you write  $x \geq -6$  and  $x < -3$  in interval notation?

a.  $[-6, -3]$

c.  $[-6, -3)$

b.  $(-6, -3)$

d.  $(-6, -3]$

81. What is the graph of  $(-\infty, -8)$  or  $(6, \infty)$ ?

a.

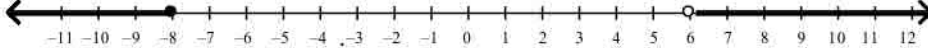

b.

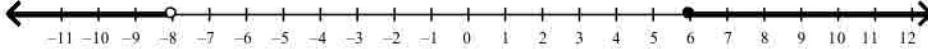

c.

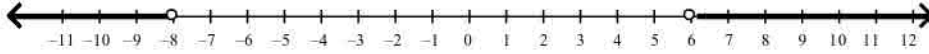

d.

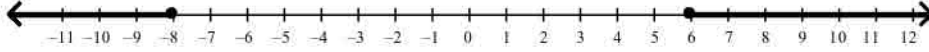

What are the solutions of the equation? Graph and check the solutions.

82.  $|x| + 10 = 1$

a.  $x = 9$

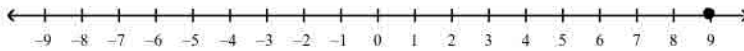

b.  $x = 9$  or  $x = -9$

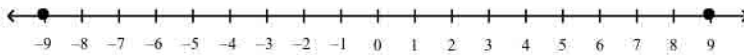

c.  $x = 0$



d. no solution

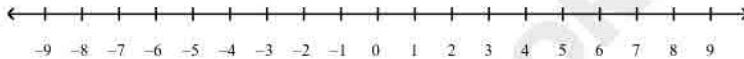

83.  $6|n| - 2 = 10$

a.  $n = 2$

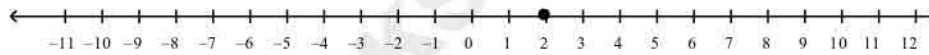

b.  $n = 2$  or  $n = -2$

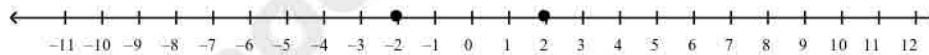

c.  $n = 6$  or  $n = -6$

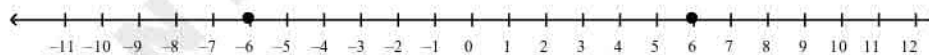

d. no solution

84.  $\left|x + \frac{1}{2}\right| = -5$

a.  $x = -5\frac{1}{2}$

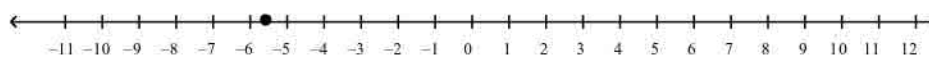

b.  $x = -5\frac{1}{2}$  or  $4\frac{1}{2}$

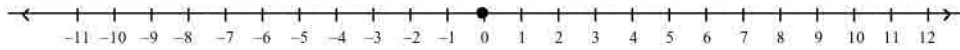

c.  $x = -5^1$  or  $5^1$

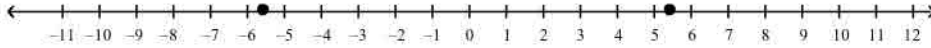

d. no solution

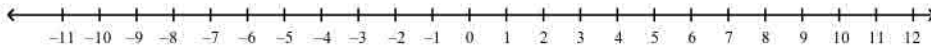

What are the solutions of the inequality? Graph the solution.

85.  $|d - 3| \geq 2$

a.  $d \leq 1$  or  $d \geq 5$

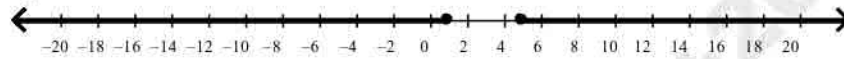

b.  $d \geq 5$

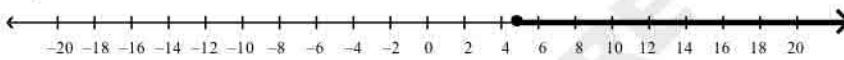

c.  $d \leq 1$

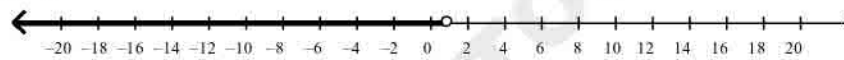

d.  $d \leq 1$  or  $d \geq 5$



86. A doctor is examining 3 patients. Which symptoms do all three patients have in common?

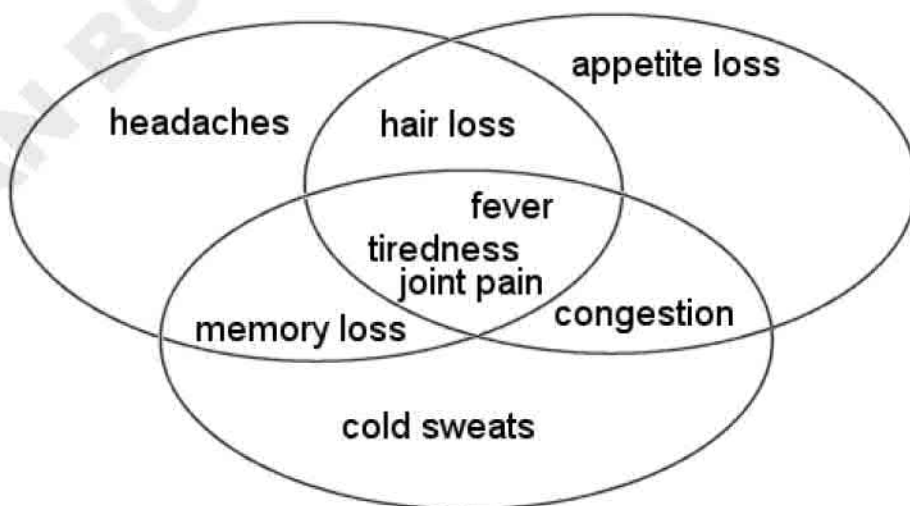

ALL QUESTIONS HAVE BEEN COLLECTED FROM PEARSON

- a. {headaches, hair loss, congestion}      c. {spasms, memory loss, appetite loss}  
 b. {cold sweats, congestion, memory loss}      d. {fever, joint pain, tiredness}

87. Bob is comparing the ingredients for three different muffin recipes. Which ingredients do all three recipes have in common?



- a. {honey, salt, wheat}      c. {wheat, baking soda, salt}  
 b. {bran, water}      d. {milk, sugar, raisins}

**What are the variables in each graph? Describe how the variables are related at various points on the graph.**

88. The graph shows the height of a hiker above sea level. The hiker walks at a constant speed for the entire trip. What are the variables? Describe how the variables are related at various points on the graph.

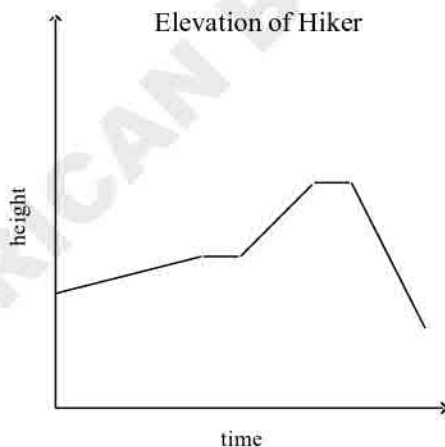

ALL QUESTIONS HAVE BEEN COLLECTED FROM PEARSON

- a. The variables are height and time. For the first part of the graph, the height is increasing slowly, which means the hiker is climbing a steep incline. Flat parts of the graph show where the elevation does not change, which means the hiker stopped to rest. The steep part at the end of the graph shows that the hiker is descending a gentle slope.
- b. The variables are height and time. For the first part of the graph, the height is increasing slowly, which means the hiker is walking up a gentle slope. Flat parts of the graph show where the elevation does not change, which means the trail is flat here. The steep part at the end of the graph shows that the hiker is descending a steep incline.
- c. The variables are height and time. For the first part of the graph, the height is increasing slowly, which means the hiker is climbing a steep incline. Flat parts of the graph show where the elevation does not change, which means the trail is flat here. The steep part at the end of the graph shows that the hiker is descending a steep incline.
- d. All of the above.

89. A new comedian is building a fan base. The table shows the number of people who attended his shows in the first, second, third and fourth month of his career. Which graph could represent the data shown in the table?

Month	Total Number of People
1	119
2	214
3	385
4	693

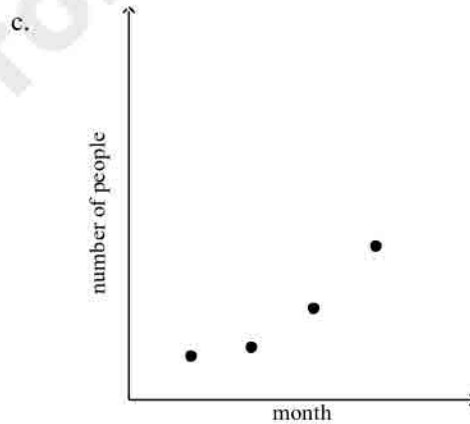
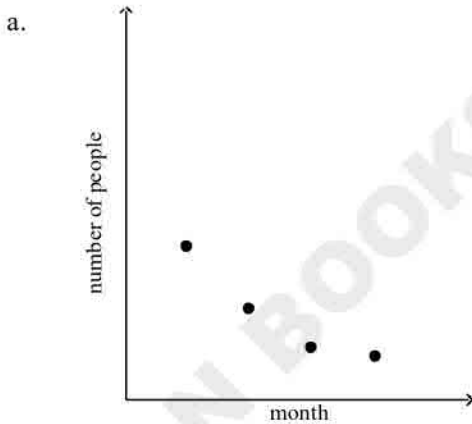

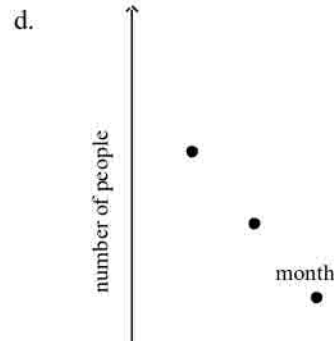
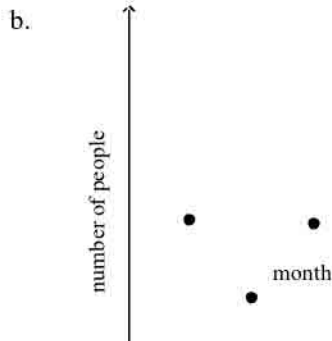

90. The table shows the amount of money made by a summer blockbuster in each of the first four weeks of its theater release. Which graph could represent the data shown in the table?

Week	Money (\$)
1	19,600,000
2	7,800,000
3	3,100,000
4	1,300,000

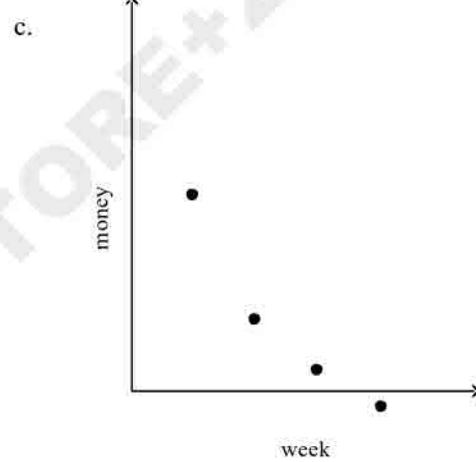
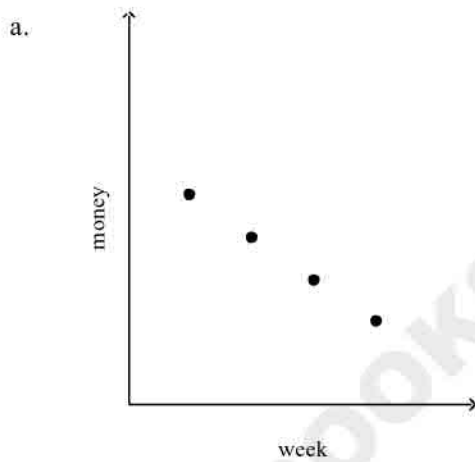

AMERICAN BOOKSTORE+201553289184

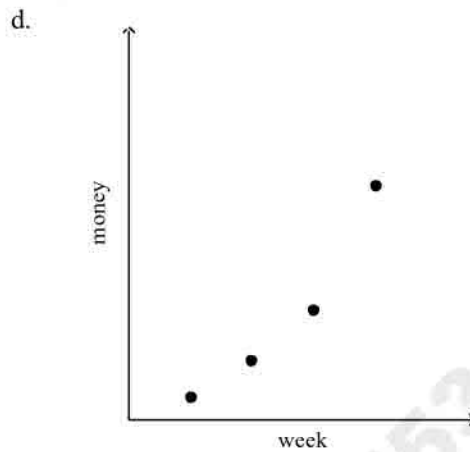
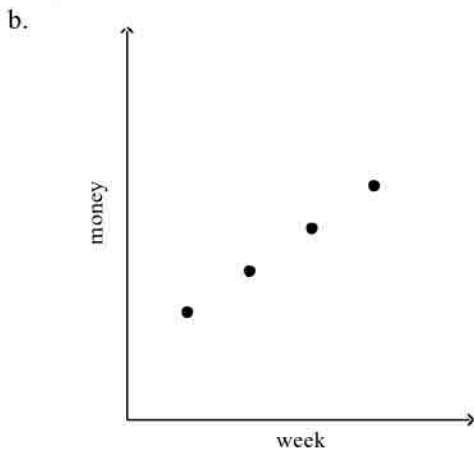

91. A hiker climbs up a steep bank and then rests for a minute. He then walks up a small hill and finally across a flat plateau. What sketch of a graph could represent the elevation of the hiker?

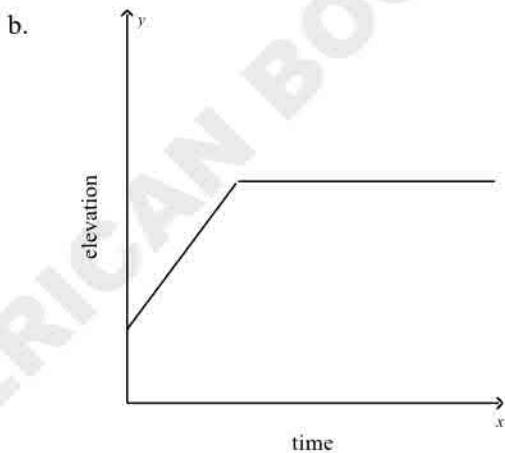
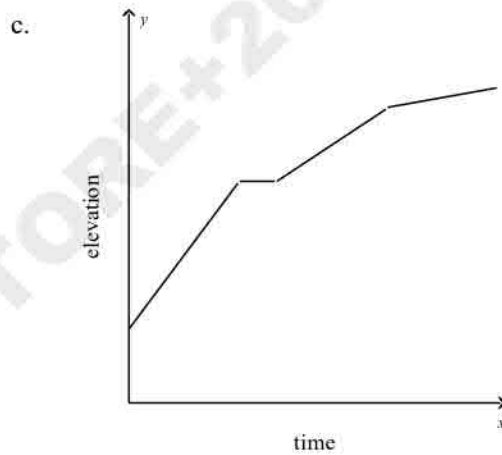
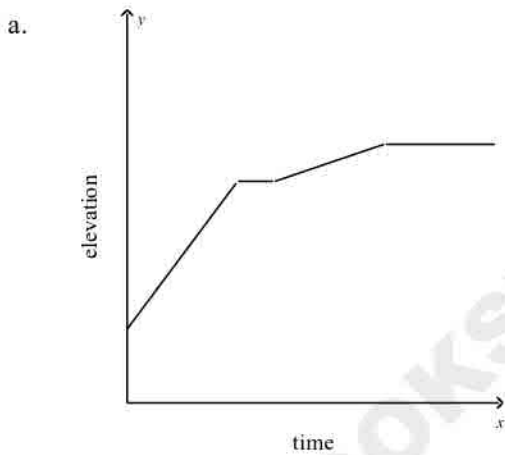

d. Any of the graphs could represent the situation, depending on the hiker's speed.

In the diagram below, what is the relationship between the number of rectangles and the perimeter of the figure they form?

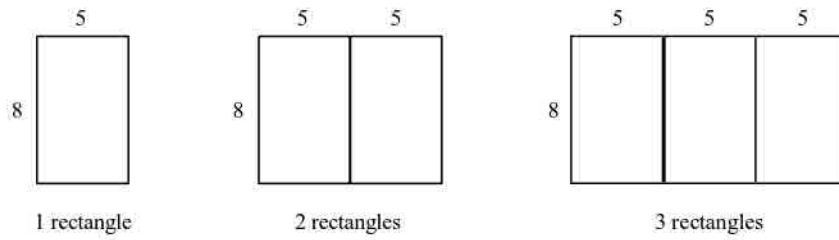

92. Which of the following tables represent the relationship in the diagram above?

a.

Number of Rectangles	Perimeter
1	52
2	72
3	92

c.

Number of Rectangles	Perimeter
1	26
2	36
3	46

b.

Number of Rectangles	Perimeter
1	13
2	18
3	23

d.

Number of Rectangles	Perimeter
1	26
2	44
3	62

In the diagram below, what is the relationship between the number of triangles and the perimeter of the figure they form?

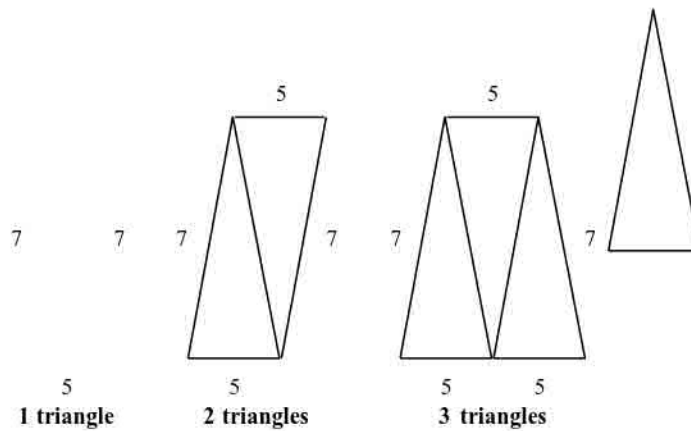

93. Which of the following represents the above relationship?

- a. The perimeter,  $P$ , is equal to the length of the base of one triangle multiplied by the number of triangles in the figure,  $n$ , plus the length of another side. The equation for the perimeter is  $P = 5n + 7$ .
- b. The perimeter,  $P$ , is equal to the length of a side of one triangle multiplied by the number of triangles in the figure,  $n$ , plus the length of the base. The equation for the perimeter is  $P = 7n + 5$ .
- c. The perimeter,  $P$ , is equal to the length of a side of one triangle multiplied by the number of triangles in the figure,  $n$ , plus two times the length of the base. The equation for the perimeter is  $P = 7n + 10$ .
- d. The perimeter,  $P$ , is equal to the length of the base of one triangle multiplied by the number of triangles in the figure,  $n$ , plus two times the length of another side. The equation for the perimeter is  $P = 5n + 14$ .

94. The ordered pairs (1, 1), (2, 4), (3, 9), (4, 16), and (5, 25) represent a function. What is a rule that represents this function?

- a.  $y = x^2$
- b.  $y = 2^x$
- c.  $y = x + 2$
- d.  $y = 2x$

95. The ordered pairs (1, 81), (2, 100), (3, 121), (4, 144), and (5, 169) represent a function. What is a rule that represents this function?

- a.  $y = x^8$
- b.  $y = 8^x$
- c.  $y = (x + 8)^2$
- d.  $y = 8x$

96. The ordered pairs (1, 6), (2, 36), (3, 216), (4, 1296), and (5, 7776) represent a function. What is a rule that represents this function?

- a.  $y = 6x$
- b.  $y = (x + 6)^2$
- c.  $y = x^6$
- d.  $y = 6^x$

**What is the graph of the function rule?**

97.  $y = 3x - 2$

a.

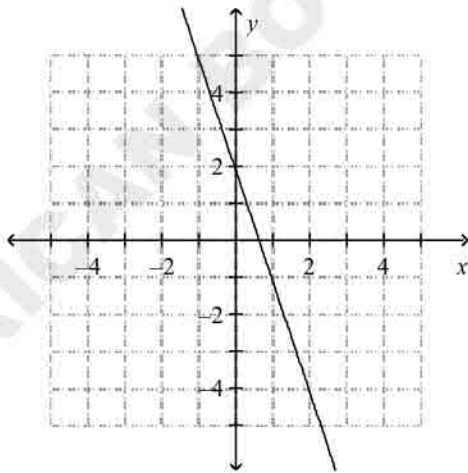

c.

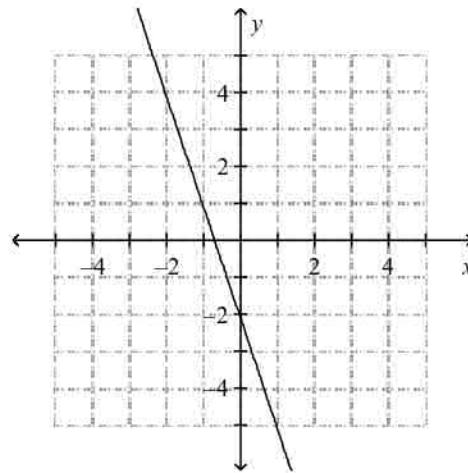

b.

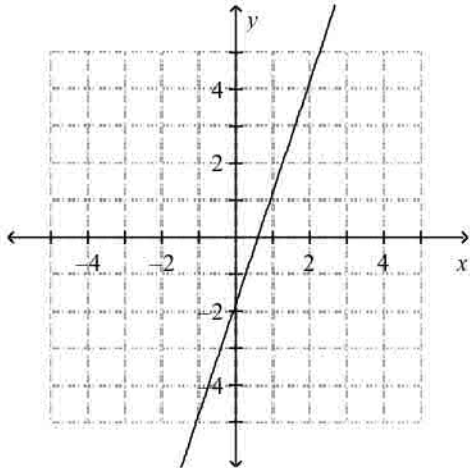

d.

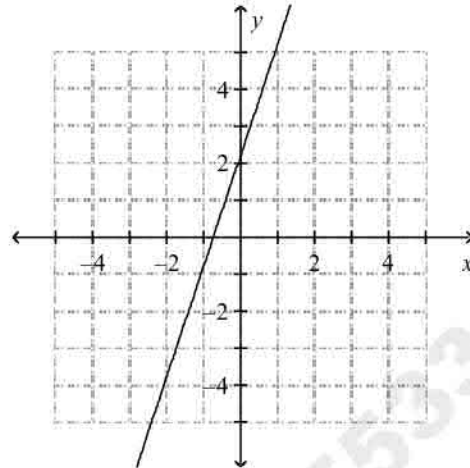

Write a function for the situation. Is the graph *continuous* or *discrete*?

98. A movie store sells DVDs for \$11 each. What is the cost,  $C$ , of  $n$  DVDs?
- |                            |                              |
|----------------------------|------------------------------|
| a. $C = 11n$ ; continuous  | c. $C = 11 + n$ ; continuous |
| b. $C = 11 + n$ ; discrete | d. $C = 11n$ ; discrete      |
99. A produce stand sells roasted peanuts for \$1.90 per pound. What is the cost,  $C$ , of  $p$  pounds of peanuts?
- |                             |                                |
|-----------------------------|--------------------------------|
| a. $C = 1.90p$ ; continuous | c. $C = 1.90 + p$ ; continuous |
| b. $C = 1.90p$ ; discrete   | d. $C = 1.90 + p$ ; discrete   |

What is the graph of each function rule?

100.  $y = |x| - 1$

a.

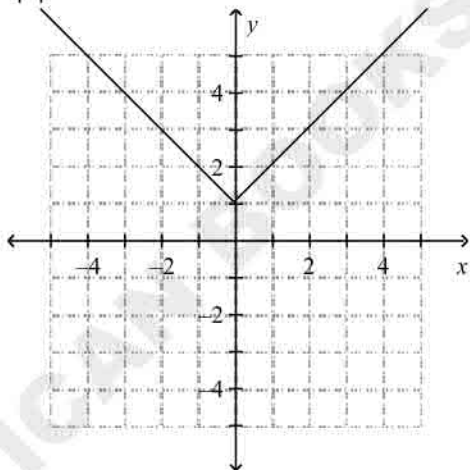

c.

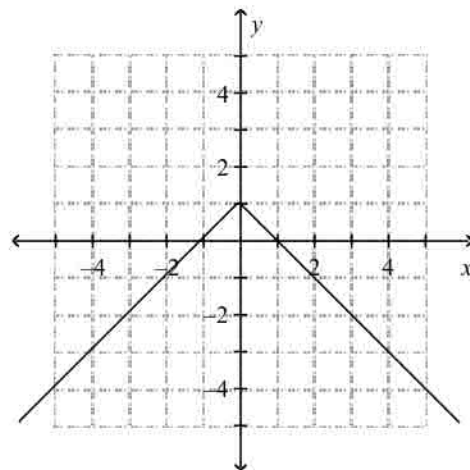

AMERICAN TEST PREP 01553389184

b.

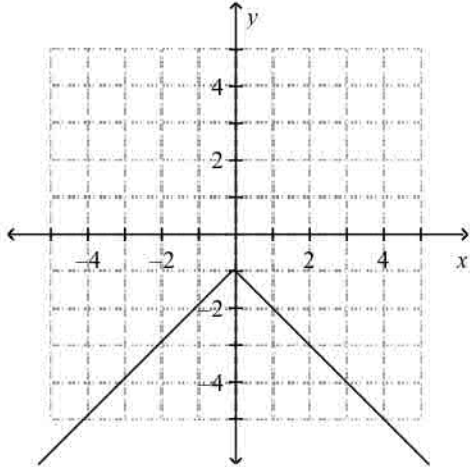

101.  $y = |3x| - 1$

a.

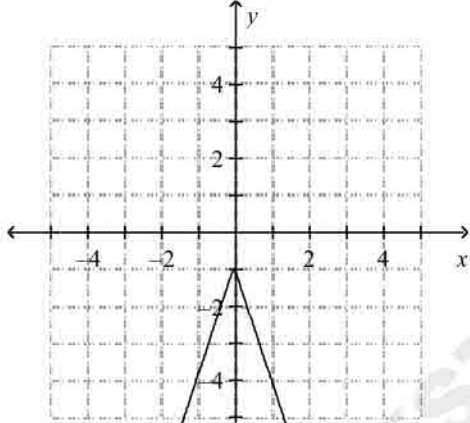

b.

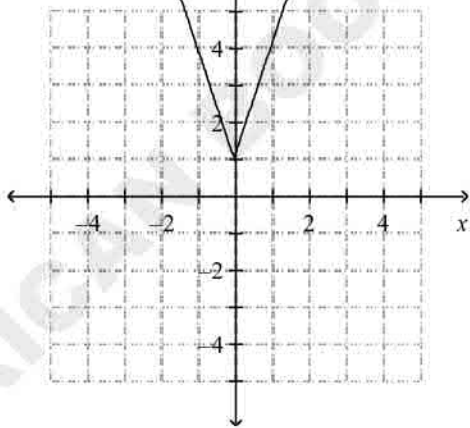

102.  $y = x^2 + 1$

d.

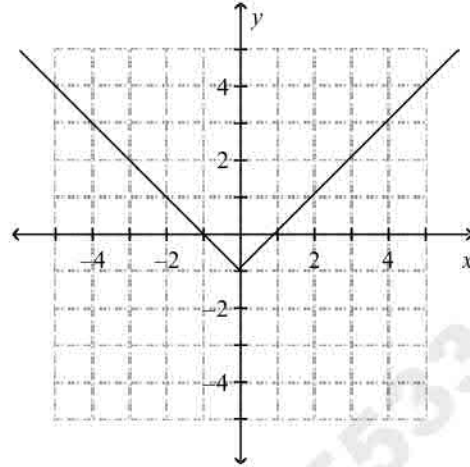

c.

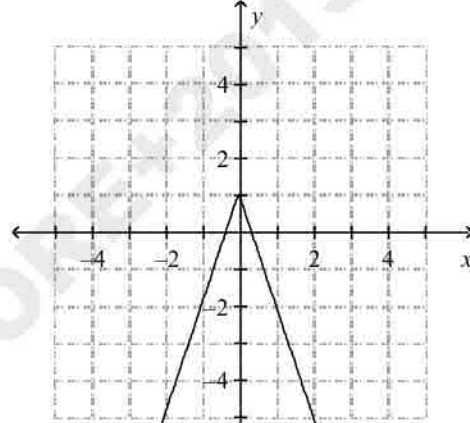

d.

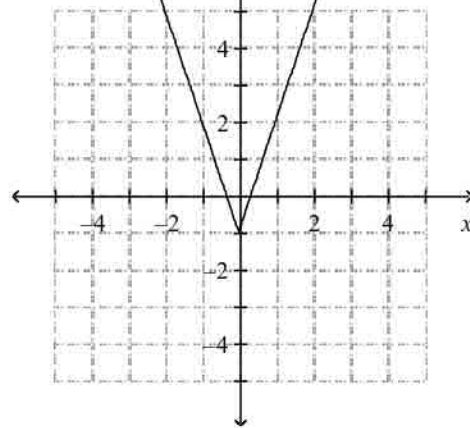

a.

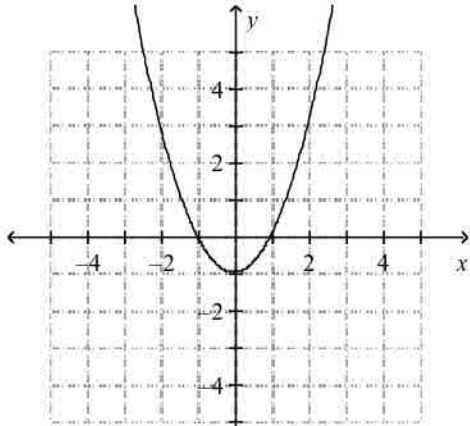

c.

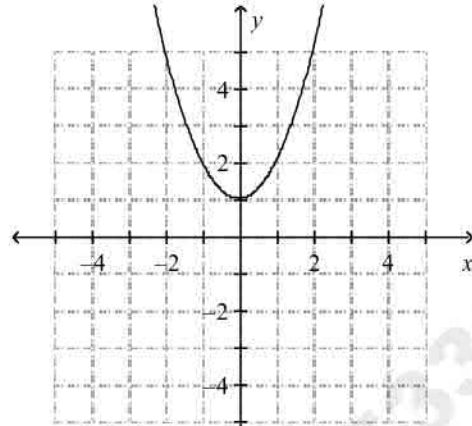

b.

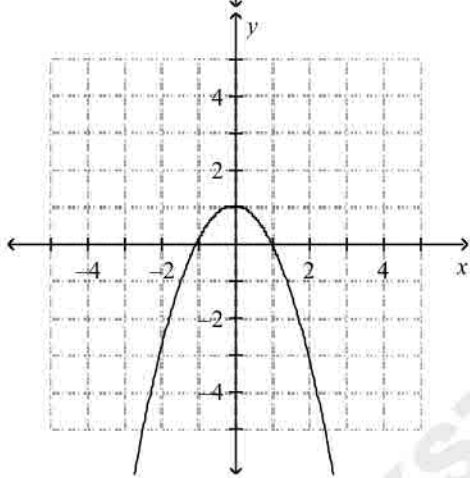

d.

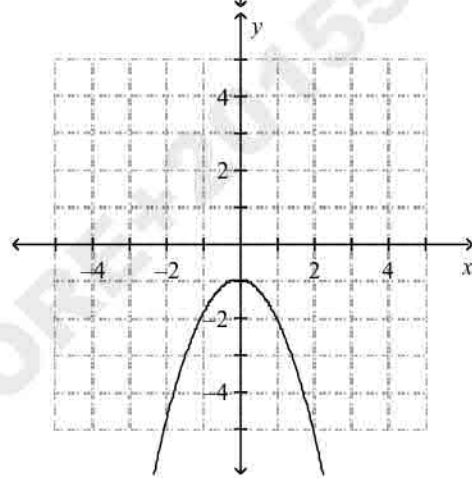

103.  $y = 2x^2 - 2$

a.

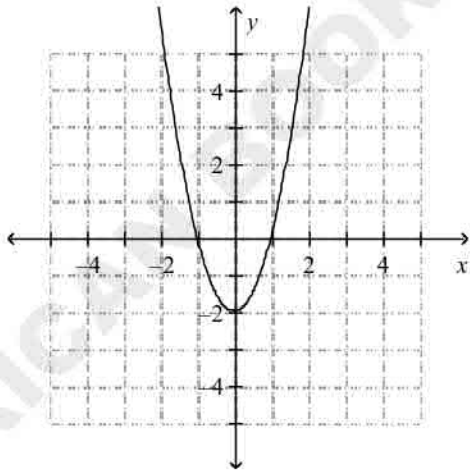

c.

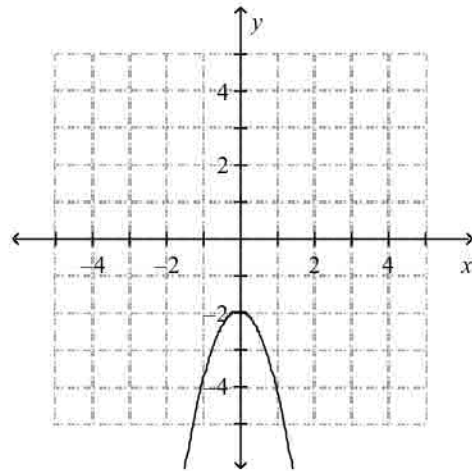

AMERICAN BOOKSTOR 01553389184

b.

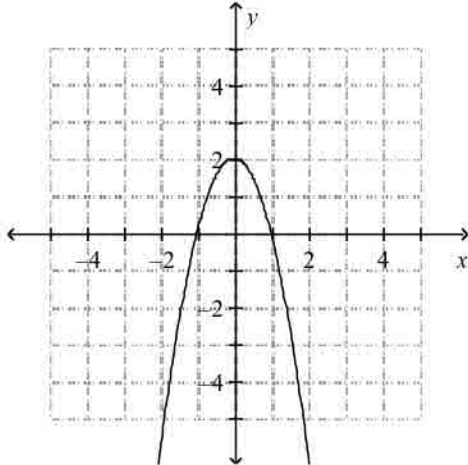

d.

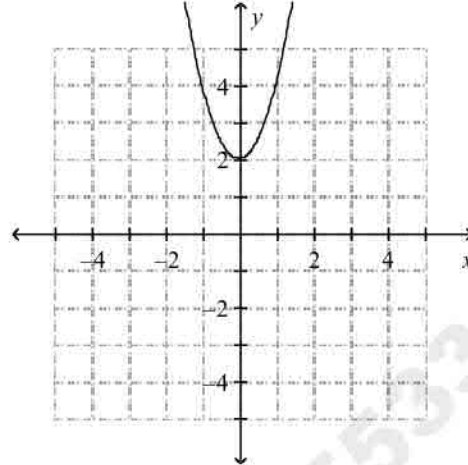

104. Write a function rule that gives the total cost  $c(p)$  of  $p$  pounds of sugar if each pound costs \$.59.

a.  $c(p) = 59p$

c.  $c(p) = p + 0.59$

b.  $c(p) = \frac{p}{0.59}$

d.  $c(p) = 0.59p$

105. Write a function rule for the area,  $A$ , of a triangle whose base,  $b$ , is 2 cm less than seven times the height,  $h$ . What is the area of the triangle when the height is 14 cm?

a.  $A = \frac{7h^2 - 2h}{2}; 672 \text{ cm}^2$

c.  $A = 7h - 2; 96 \text{ cm}^2$

b.  $A = \frac{7h - 2}{2}; 48 \text{ cm}$

d.  $A = 7h^2 - 2h; 1344 \text{ cm}^2$

Find the slope of the line.

106.

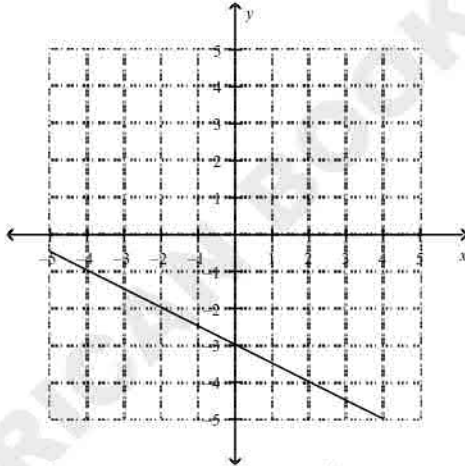

a.  $\frac{1}{2}$

b.  $-\frac{1}{2}$

c.  $-2$

d.  $2$

107.

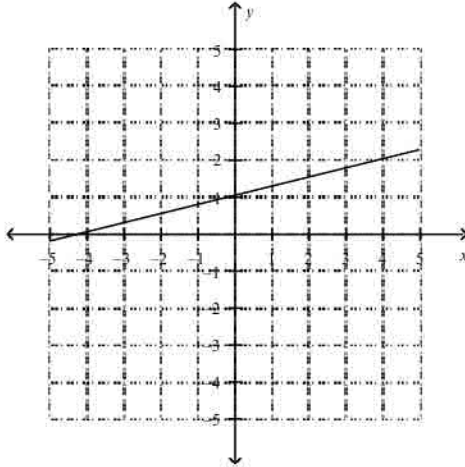

- a.  $-4$       b.  $-\frac{1}{4}$       c.  $\frac{1}{4}$       d.  $4$

What is the slope of the line that passes through the pair of points?

108.  $(1, 7), (10, 1)$

- a.  $3$       b.  $-\frac{2}{3}$       c.  $-\frac{3}{2}$       d.  $\frac{2}{3}$

109.  $(-\frac{5}{3}, -1), (-\frac{2}{9}, 2)$

- a.  $\frac{2}{33}$       b.  $-\frac{2}{33}$       c.  $-\frac{33}{2}$       d.  $\frac{33}{2}$

What is the slope of the line?

110.

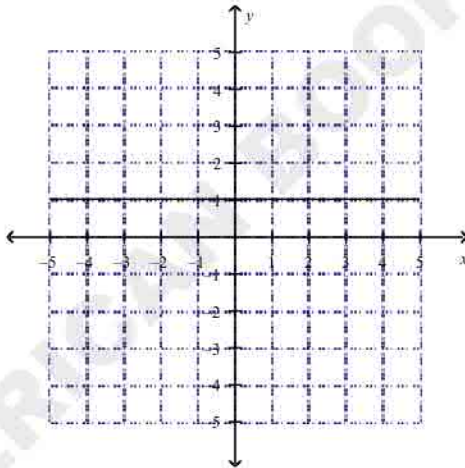

- a. undefined      b.  $0$

111.

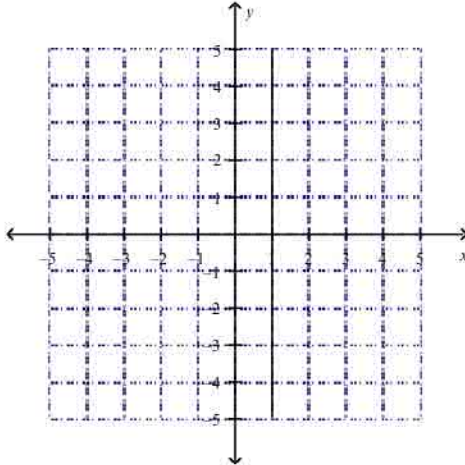

a. 0

b. undefined

Does the equation represent a direct variation? If so, find the constant of variation.

112.  $5x = -3y$

a. no

b. yes;  $k = -\frac{5}{3}$

c. yes;  $k = \frac{5}{3}$

d. yes;  $k = -\frac{3}{5}$

113.  $2x - 4y = 0$

a. yes;  $k = -4$

b. no

c. yes;  $k = \frac{1}{2}$

d. yes;  $k = -\frac{1}{2}$

114.  $2x^2 + 4y = 0$

a. no

b. yes;  $k = \frac{1}{2}$

c. yes;  $k = 2$

d. yes;  $k = -\frac{1}{2}$

115. Suppose  $y$  varies directly with  $x$ , and  $y = 10$  when  $x = -3$ . What direct variation equation relates  $x$  and  $y$ ? What is the value of  $y$  when  $x = -1$ ?

a.  $y = -\frac{3}{10}x; \frac{10}{3}$

c.  $y = \frac{10}{3}x; -\frac{10}{3}$

b.  $y = \frac{1}{10}x; -\frac{3}{10}$

d.  $y = -\frac{10}{3}x; \frac{10}{3}$

116. Suppose  $y$  varies directly with  $x$ , and  $y = 8$  when  $x = -6$ . What direct variation equation relates  $x$  and  $y$ ? What is the value of  $y$  when  $x = -2$ ?

a.  $y = -0.75x; 1.50$

c.  $y = 1.33x; -2.67$

b.  $y = -1.33x; 2.67$

d.  $y = 0.13x; -0.25$

117. Suppose  $y$  varies directly with  $x$ , and  $y = \frac{19}{3}$  when  $x = \frac{4}{5}$ . What direct variation equation relates  $x$  and  $y$ ? What is the value of  $y$  when  $x = -\frac{7}{6}$ ?

a.  $y = -\frac{12}{95}x; \frac{14}{95}$

c.  $y = \frac{12}{95}x; -\frac{14}{95}$

b.  $y = \frac{95}{12}x; -\frac{665}{72}$

d.  $y = -\frac{95}{12}x; \frac{665}{72}$

For the data in the table, does  $y$  vary directly with  $x$ ? If it does, write an equation for the direct variation.

118.

$x$	$y$
8	11
16	22
24	33

- a. yes;  $y = 2.75x$   
 b. yes;  $y = 0.6875x$   
 c. yes;  $y = 1.375x$   
 d. no;  $y$  does not vary directly with  $x$

119.

$x$	$y$
16	4
32	16
48	36

- a. yes;  $y = 2x$   
 b. yes;  $y = 4x$   
 c. yes;  $y = 8x$   
 d. no;  $y$  does not vary directly with  $x$

**What are the slope and  $y$ -intercept of the graph of the given equation?**

120.  $y = -4x + 2$

- a. The slope is  $-2$  and the  $y$ -intercept is  $-4$ .  
 b. The slope is  $2$  and the  $y$ -intercept is  $-4$ .  
 c. The slope is  $4$  and the  $y$ -intercept is  $-2$ .  
 d. The slope is  $-4$  and the  $y$ -intercept is  $2$ .

121.  $y = 9x - \frac{10}{3}$

- a. The slope is  $\frac{10}{3}$  and the  $y$ -intercept is  $\frac{8}{9}$ .  
 b. The slope is  $-\frac{10}{3}$  and the  $y$ -intercept is  $\frac{8}{9}$ .  
 c. The slope is  $\frac{8}{9}$  and the  $y$ -intercept is  $-\frac{10}{3}$ .  
 d. The slope is  $\frac{9}{8}$  and the  $y$ -intercept is  $\frac{10}{3}$ .

**Write an equation of a line with the given slope and  $y$ -intercept.**

122.  $m = -5, b = -3$

- a.  $y = -5x - 3$   
 b.  $y = -5x + 3$   
 c.  $y = 5x - 3$   
 d.  $y = -3x - 5$

**Write the slope-intercept form of the equation for the line.**

123.

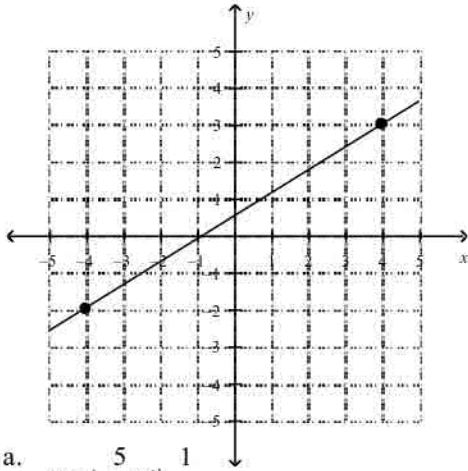

a.  $y = -\frac{5}{8}x + 1$

b.  $y = \frac{8}{5}x - \frac{1}{2}$

c.  $y = \frac{5}{8}x + \frac{1}{2}$

d.  $y = \frac{8}{5}x + \frac{1}{2}$

124.

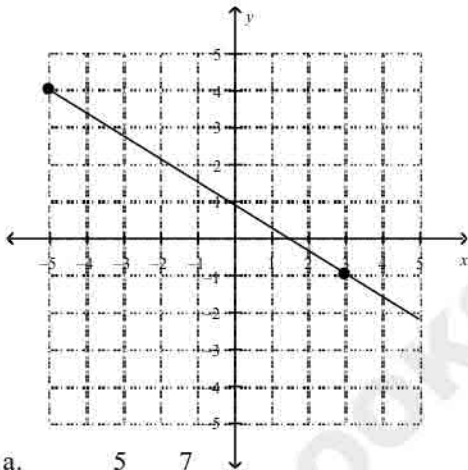

a.  $y = -\frac{5}{8}x + \frac{7}{8}$

b.  $y = \frac{5}{8}x + \frac{7}{8}$

c.  $y = \frac{7}{8}x + \frac{5}{8}$

d.  $y = -\frac{8}{5}x + \frac{7}{8}$

Graph the equation.

125.  $y = 4x - 3$

AMERICAN BOOKSTORE+201553389184

a.

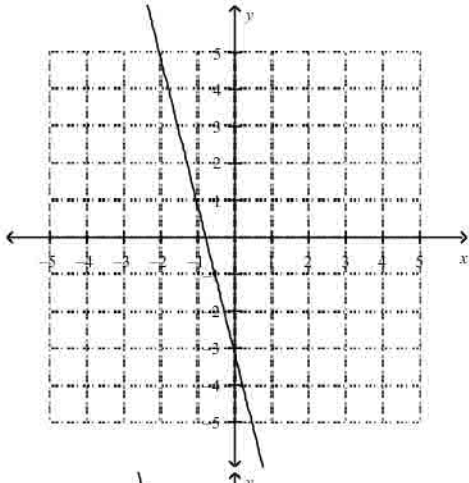

c.

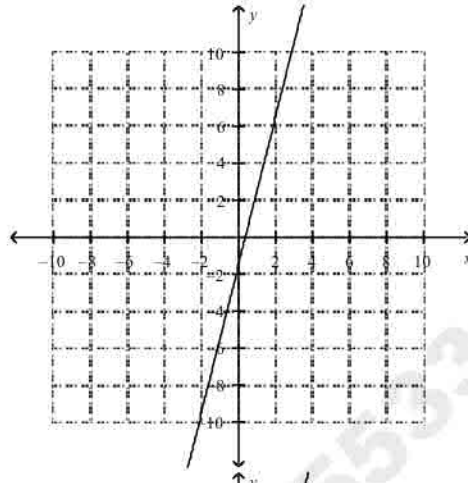

b.

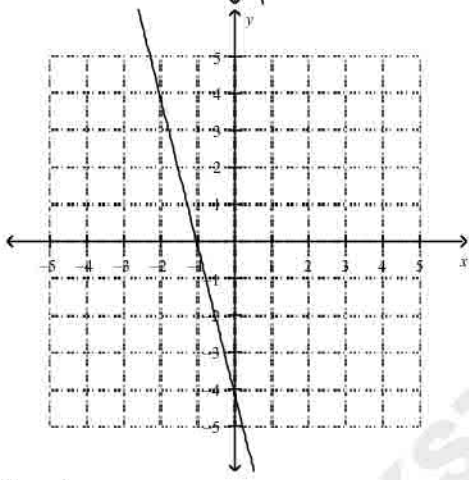

d.

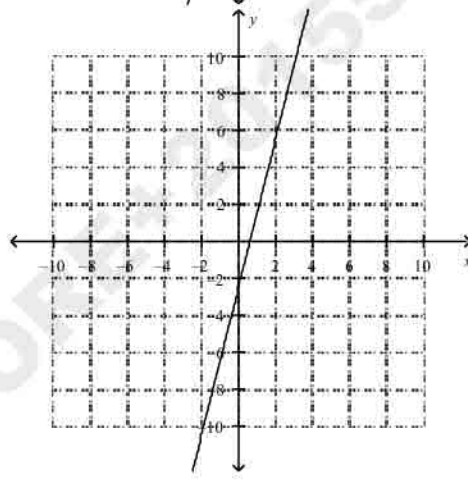

126.  $y = -2x - 3$

a.

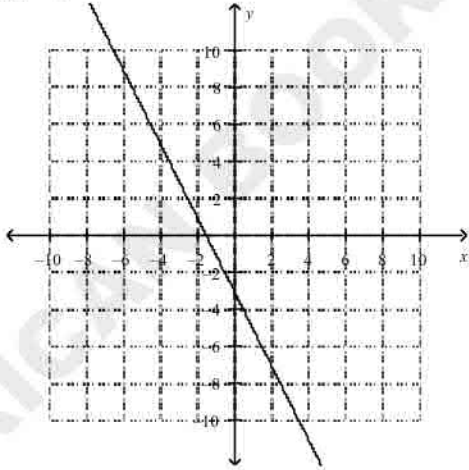

c.

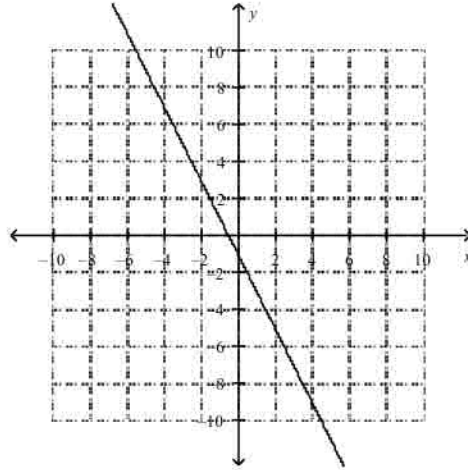

b.

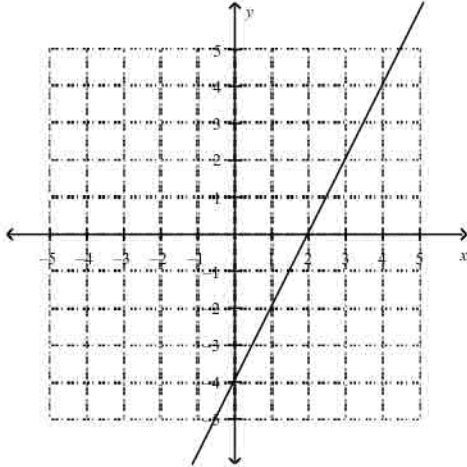

d.

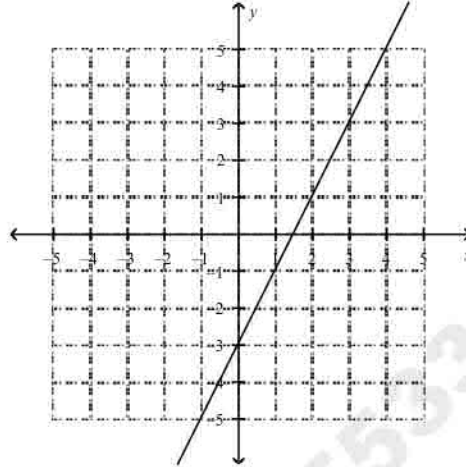

Write an equation in point-slope form for the line through the given point with the given slope.

\_\_\_ 127.  $(8, 3); m = 6$

a.  $y + 3 = 6(x - 8)$

b.  $y - 3 = 6(x - 8)$

c.  $y - 3 = 6(x + 8)$

d.  $y + 3 = 6x + 8$

\_\_\_ 128.  $(-10, -6); m = -\frac{5}{8}$

a.  $y - 6 = -\frac{5}{8}(x - 10)$

b.  $y - 6 = -\frac{5}{8}(x + 10)$

c.  $y + 6 = -\frac{5}{8}(x + 10)$

d.  $y + 10 = -\frac{5}{8}(x + 6)$

Find the  $x$ - and  $y$ -intercept of the line.

\_\_\_ 129.  $-4x + 2y = 24$

a.  $x$ -intercept is  $-6$ ;  $y$ -intercept is  $12$

b.  $x$ -intercept is  $12$ ;  $y$ -intercept is  $-6$

c.  $x$ -intercept is  $-4$ ;  $y$ -intercept is  $2$

d.  $x$ -intercept is  $2$ ;  $y$ -intercept is  $-4$

\_\_\_ 130.  $-2.9x + 5.4y = 140.94$

a.  $x$ -intercept is  $26.1$ ;  $y$ -intercept is  $-48.6$

b.  $x$ -intercept is  $-48.6$ ;  $y$ -intercept is  $26.1$

c.  $x$ -intercept is  $-2.9$ ;  $y$ -intercept is  $5.4$

d.  $x$ -intercept is  $5.4$ ;  $y$ -intercept is  $-2.9$

Match the equation with its graph.

\_\_\_ 131.  $-4x - 2y = 8$

a.

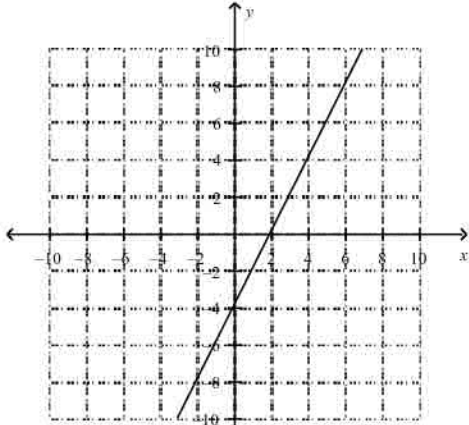

c.

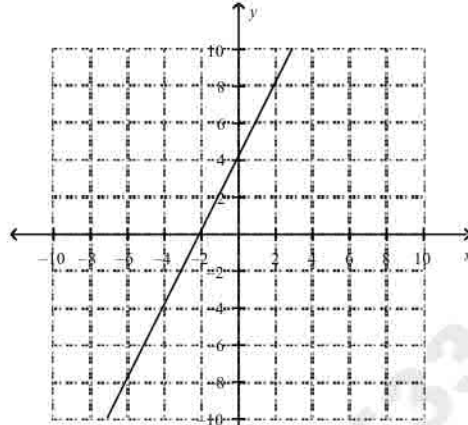

b.

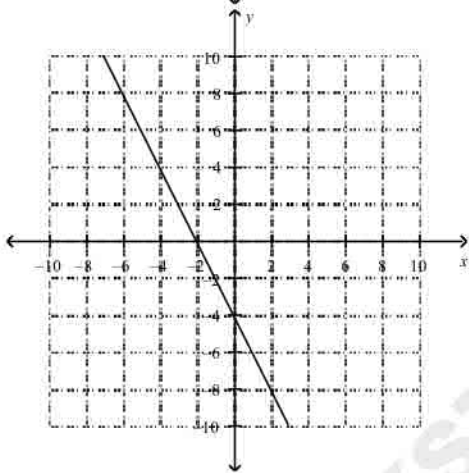

d.

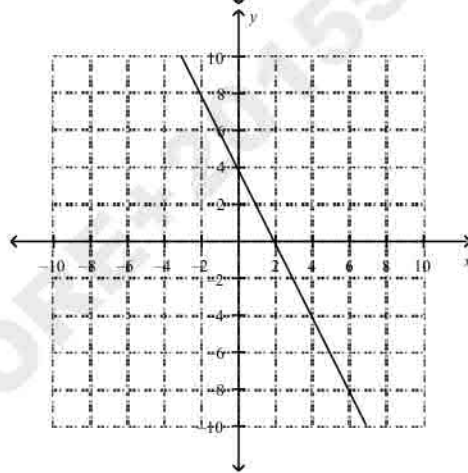

132.  $0.5x + 0.2y = 0.1$

a.

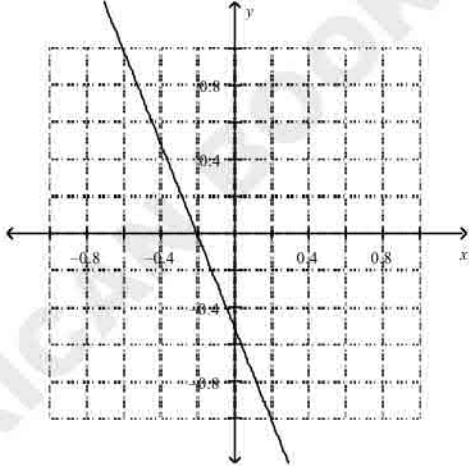

c.

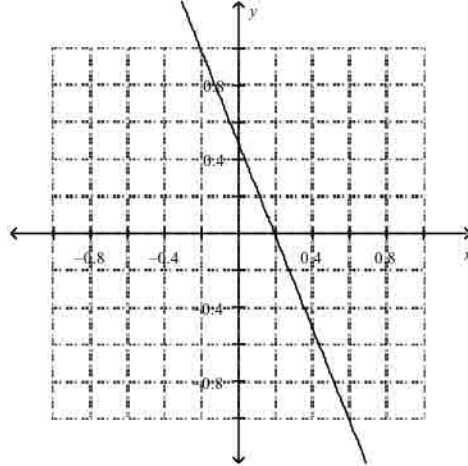

AMERICAN EDITION  
 553389184

b.

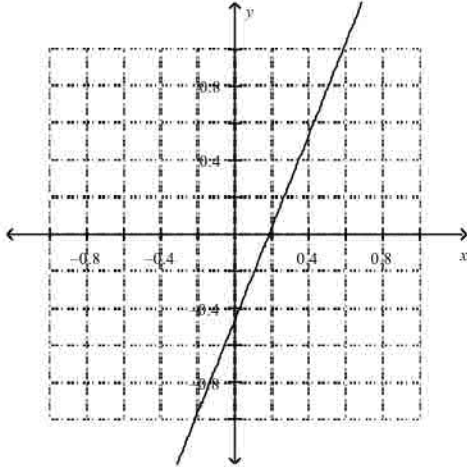

d.

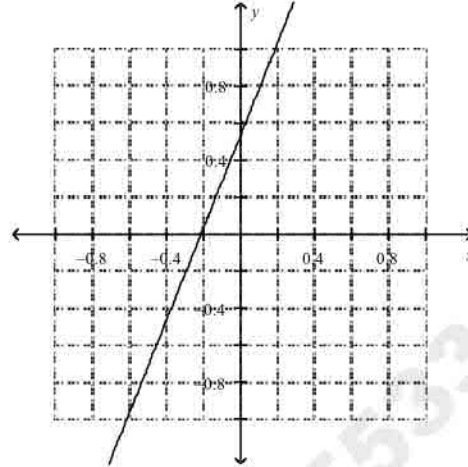

What is the graph of the equation?

133.  $y = -2$

a.

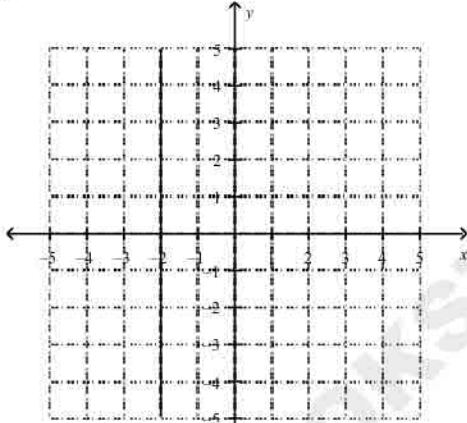

c.

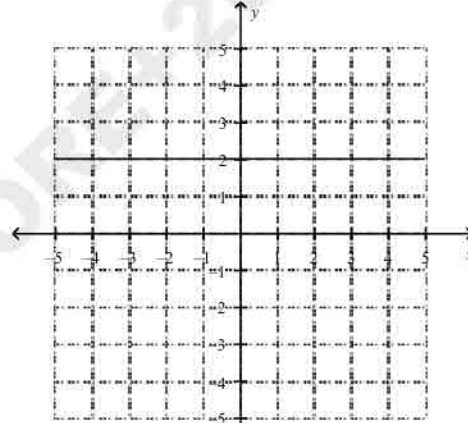

b.

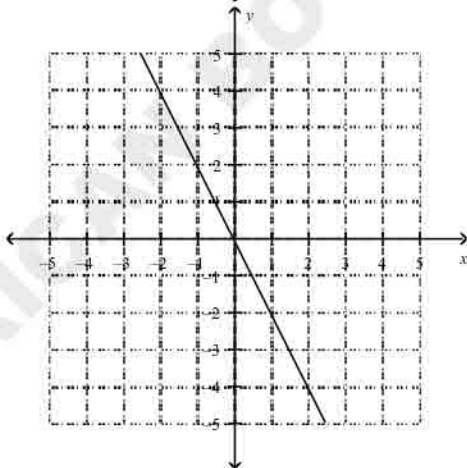

d.

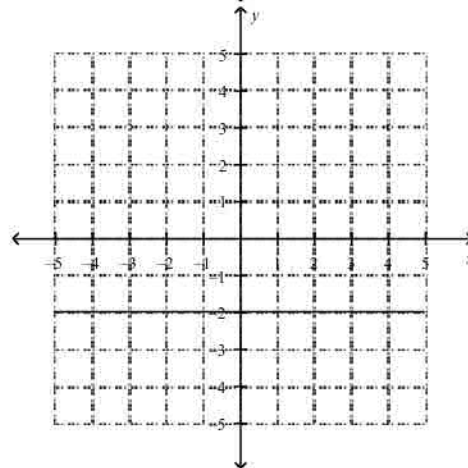

134.  $x = 1$

a.

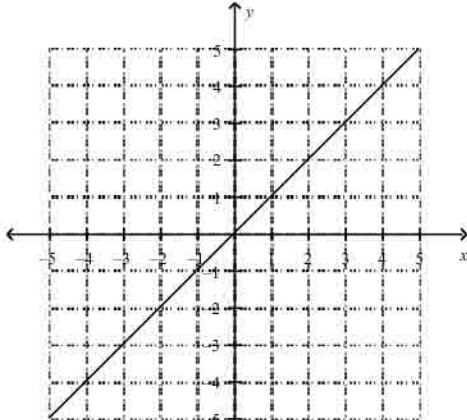

c.

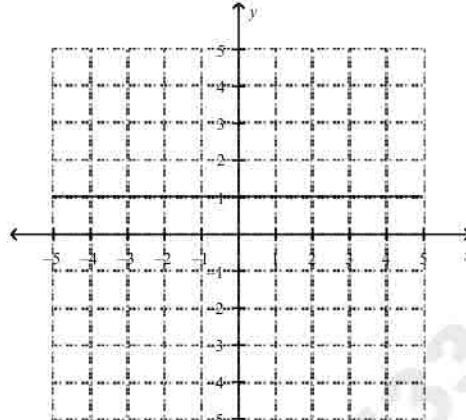

b.

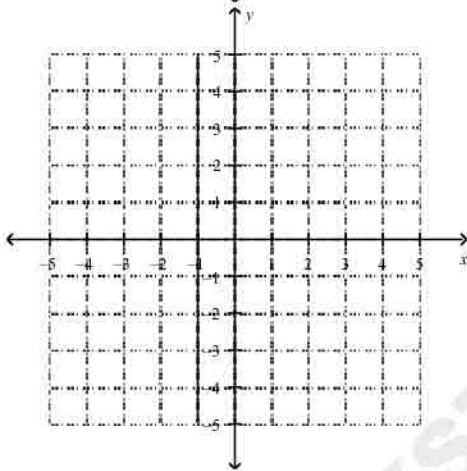

d.

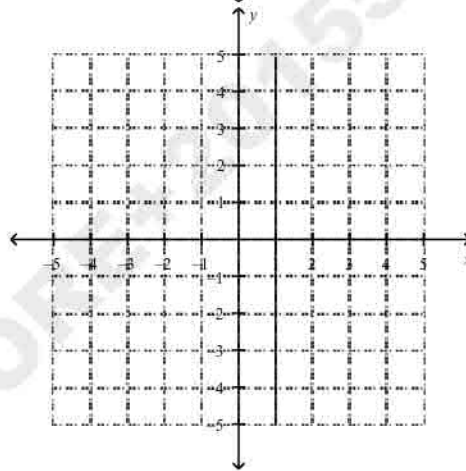

Write an equation for the line that is parallel to the given line and passes through the given point.

135.  $y = 5x + 8$ ;  $(2, 16)$

a.  $y = 5x - 78$

b.  $y = 5x + 6$

c.  $y = -\frac{1}{5}x - 6$

d.  $y = \frac{1}{5}x + 6$

136.  $y = \frac{5}{3}x - 8$ ;  $(-15, -23)$

a.  $y = -\frac{5}{3}x + 14$

b.  $y = \frac{3}{5}x - 6$

c.  $y = \frac{3}{5}x - 14$

d.  $y = \frac{5}{3}x - 14$

137.  $y = 5.2x + 6.5$ ;  $(6.8, 8.3)$

a.  $y = -5.2x - 43.66$

b.  $y = -5.2x + 43.66$

c.  $y = 5.2x - 27.06$

d.  $y = 5.2x + 43.66$

Tell whether the lines for each pair of equations are *parallel*, *perpendicular*, or *neither*.



144.

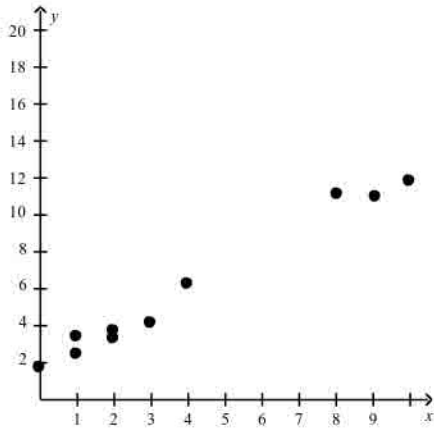

- a. positive correlation
- b. negative correlation
- c. no correlation

145.

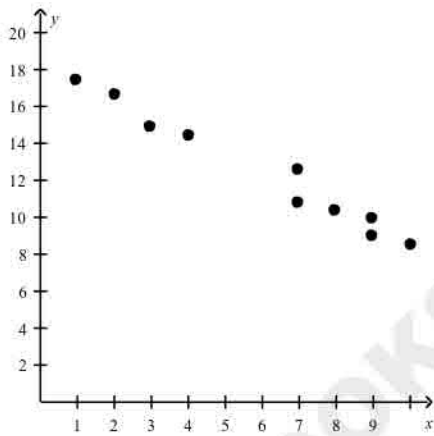

- a. positive correlation
- b. negative correlation
- c. no correlation

146.

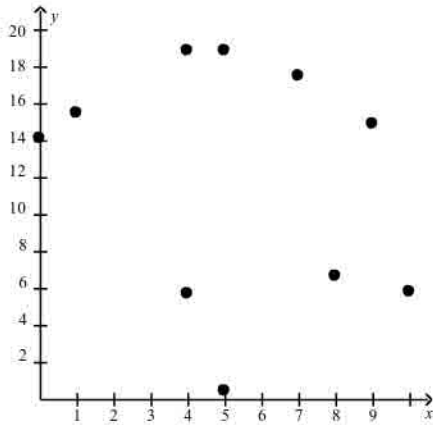

- a. positive correlation
- b. negative correlation
- c. no correlation

147. The scatter plot shows the number of mistakes a piano student makes during a recital versus the amount of time the student practiced for the recital. How many mistakes do you expect the student to make at the recital after 6 hours of practicing?

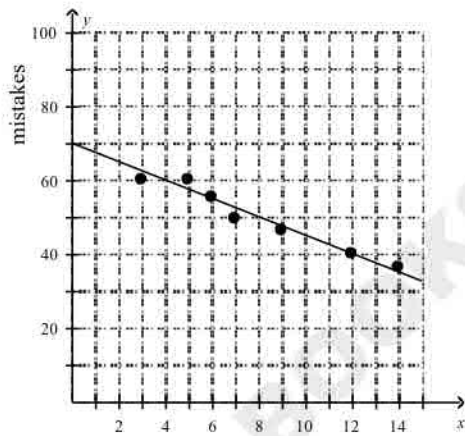

- a. 55 mistakes
- b. 37 mistakes
- c. 63 mistakes
- d. 45 mistakes

148. The scatter plot below shows the height of a tree over time. What is the approximate height of the tree after 10 years?

AMERICAN EASY STORE #01553389184

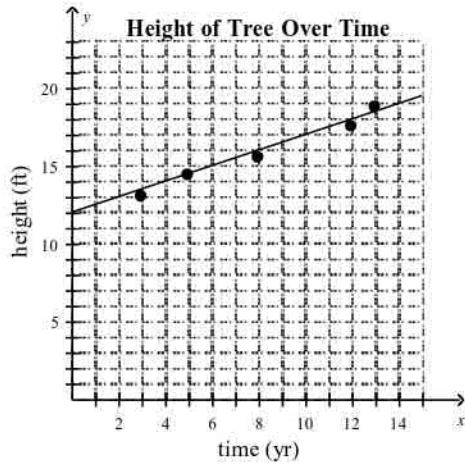

- a. 13 ft  
 b. 20 ft  
 c. 17 ft  
 d. 21 ft

What is the solution of the system? Use a graph.

149.  $y = -x + 2$   
 $y = 3x - 1$

a.

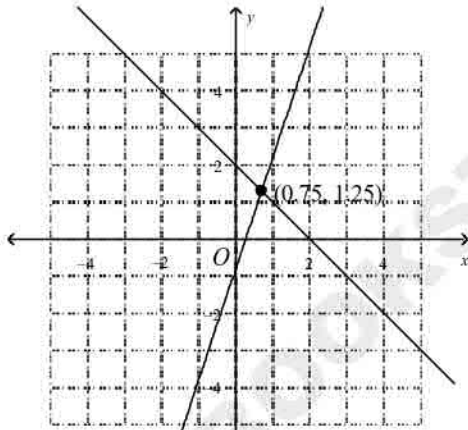

b.

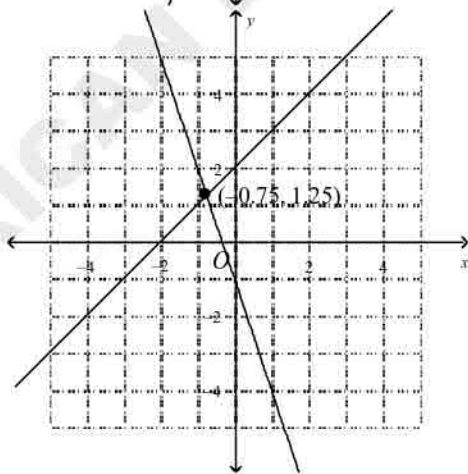

c.

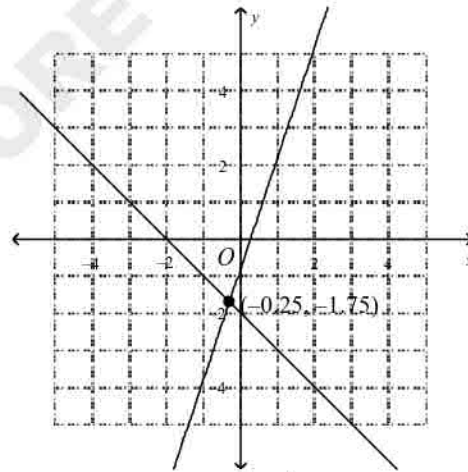

d.

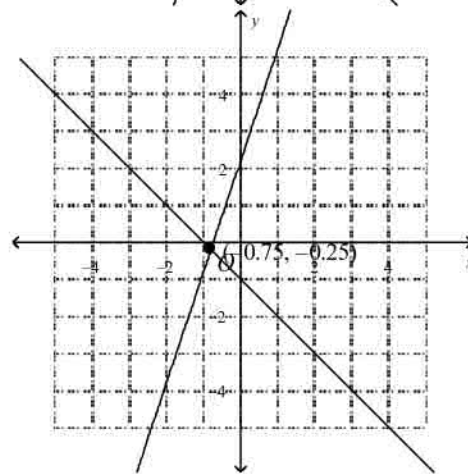

150.  $-4x + 3y = -12$

$$-2x + 3y = -18$$

a.

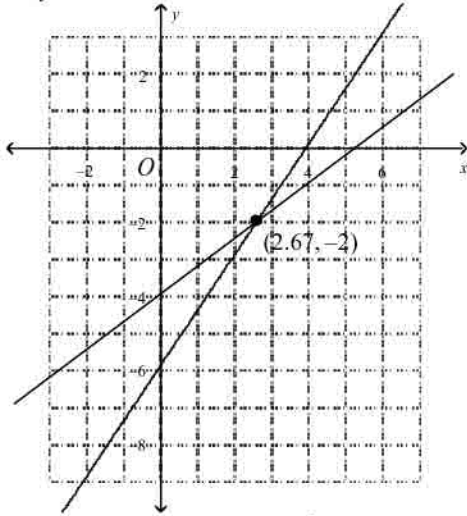

c.

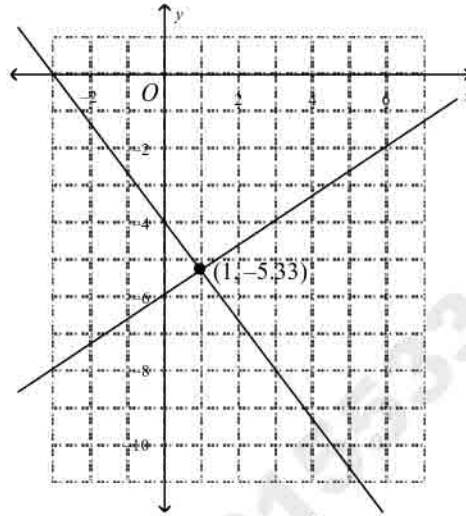

b.

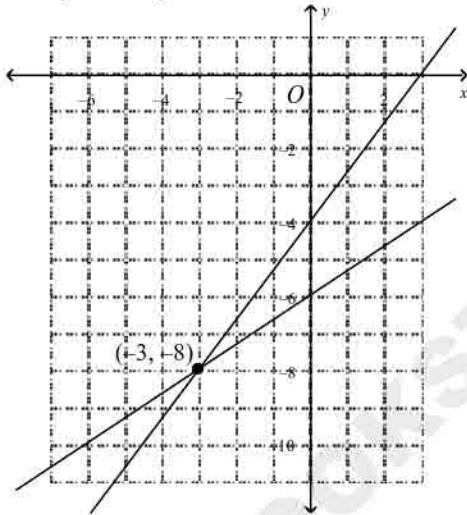

d.

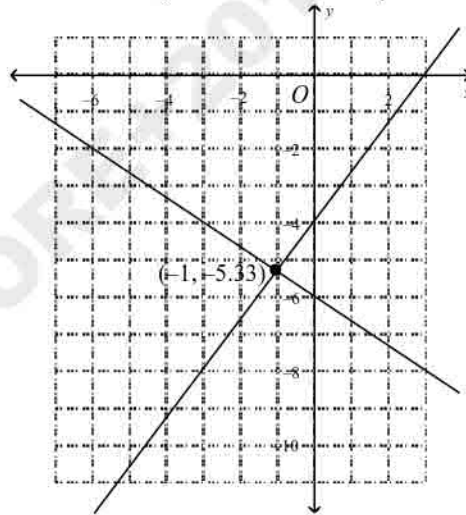

What is the solution of the system? Use a graph.

\_\_\_ 151.  $y = 5x + 4$   
 $y = 5x - 3$

a.

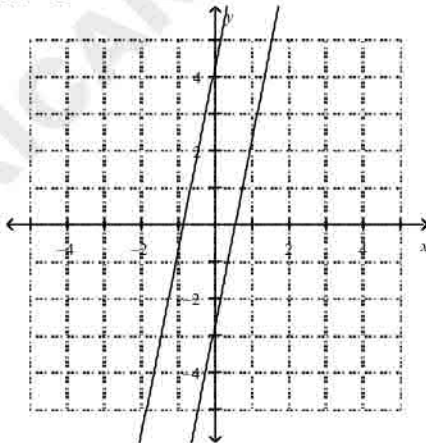

c.

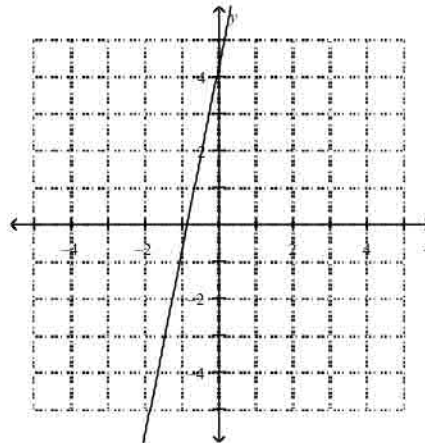

no solutions

b.

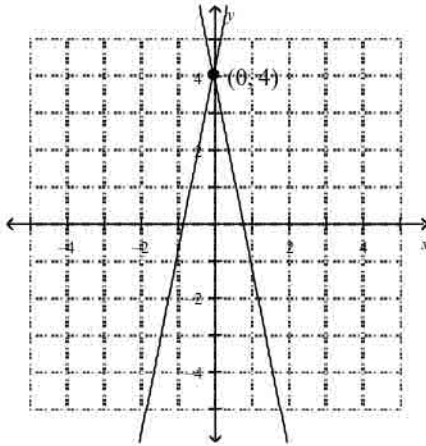

(0, 4)

infinitely many solutions

d.

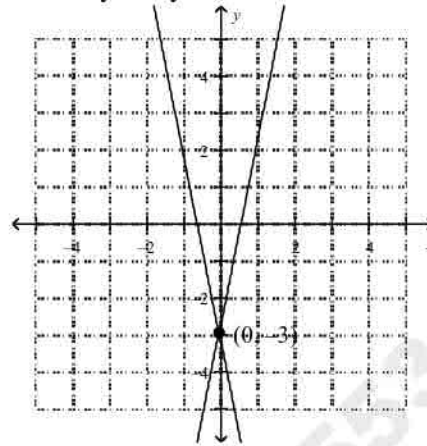

(0, -3)

152.  $y = -5x - 2$   
 $y + 2 = -5x$

a.

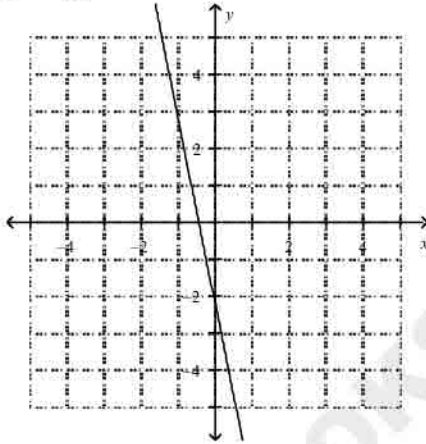

infinitely many solutions

b.

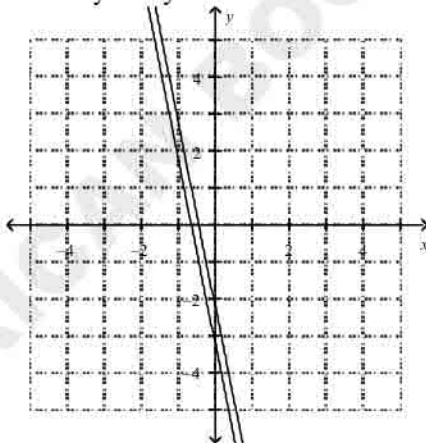

no solutions

c.

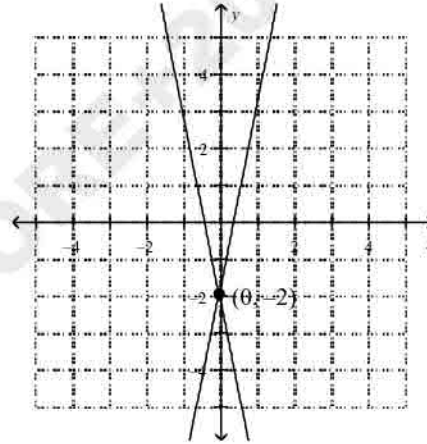

(0, -2)

d.

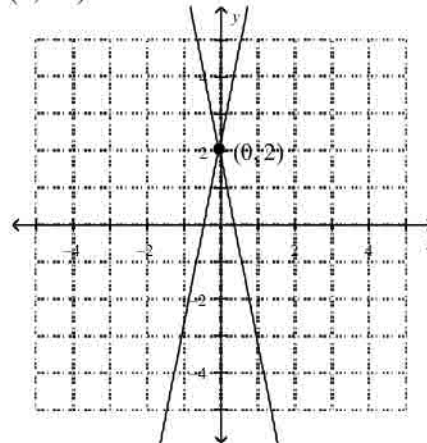

(0, 2)

What is the solution of the system? Use substitution.

153.  $3x + 2y = 7$

$$y = -3x + 11$$

a.  $(6, -3)$

b.  $(6, -7)$

c.  $\left(-4, \frac{19}{2}\right)$

d.  $(5, -4)$

154.  $x = -3y - 4$

$$-3y = 2x - 7$$

$$z = -6x + y$$

a.  $x = -5, y = 11, z = -71$

b.  $x = 11, y = -71, z = -5$

c.  $x = -71, y = -5, z = 11$

d.  $x = 11, y = -5, z = -71$

Which ordered pair is a solution of the inequality?

155.  $y \geq 4x - 5$

a.  $(3, 4)$

b.  $(2, 1)$

c.  $(3, 0)$

d.  $(1, 1)$

156.  $2y + 6 < 8x$

a.  $(4, 13)$

b.  $(-5, 2)$

c.  $(0, 6)$

d.  $(4, 8)$

Graph the inequality.

157.  $y < 3x - 5$

a.

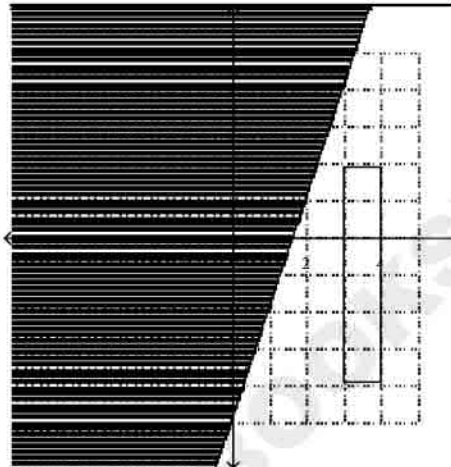

b.

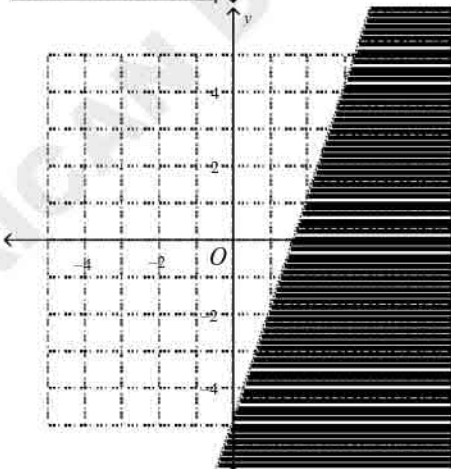

c.

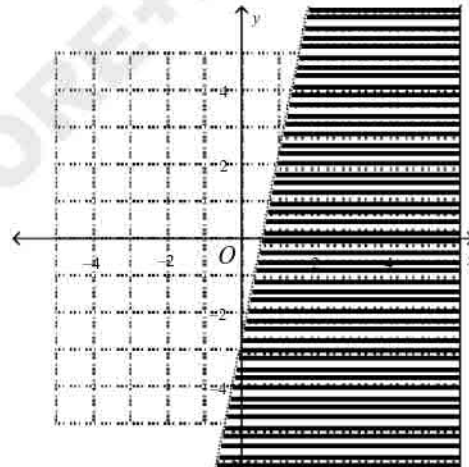

d.

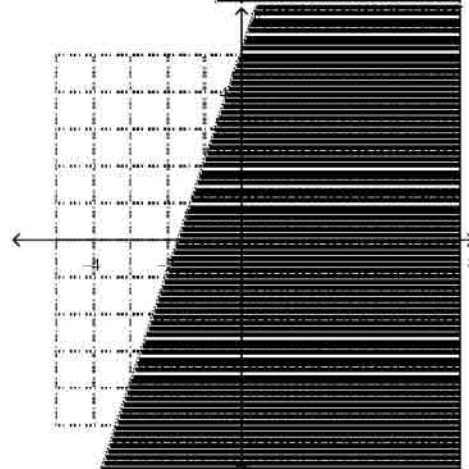

158.  $4x + 6y \geq 10$

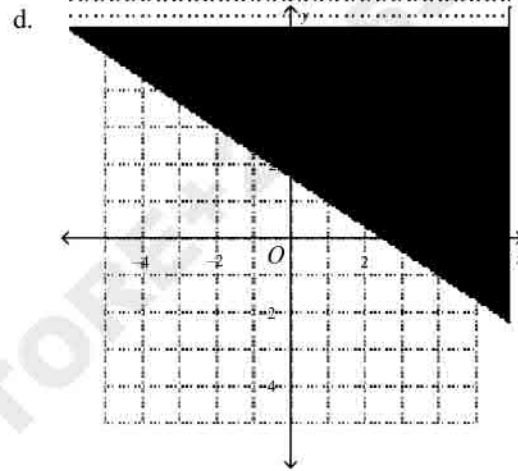
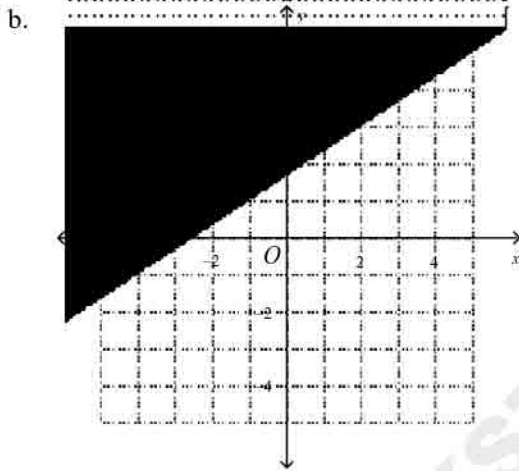
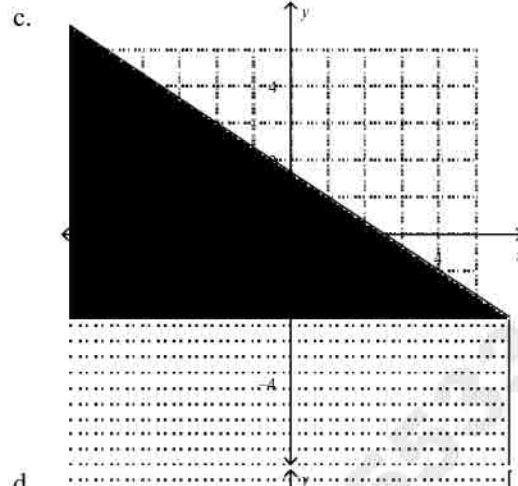
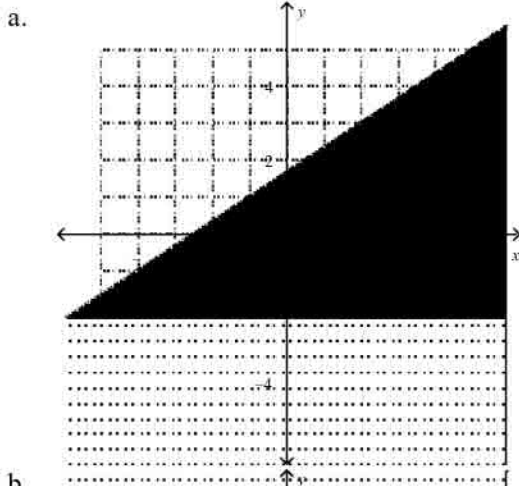

159.  $3x - 2y < -21$

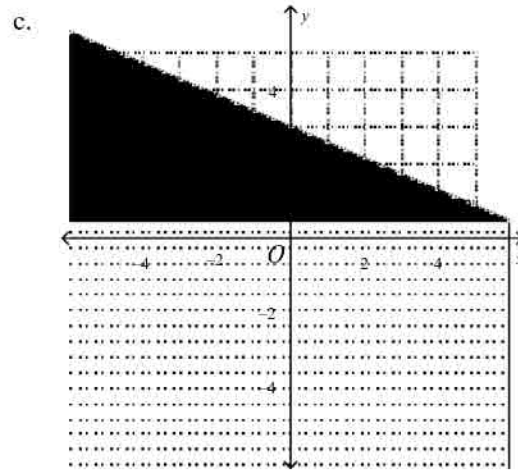
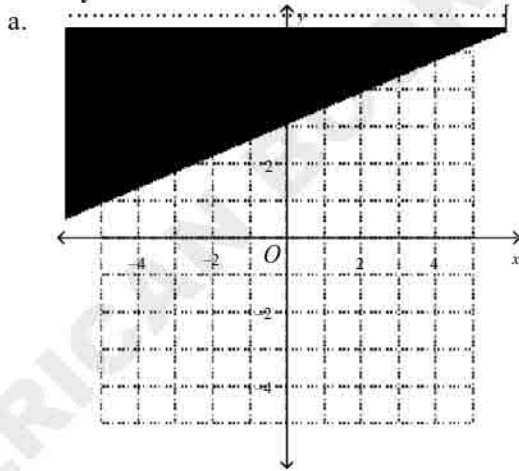

AMERICAN KSTOR 89184

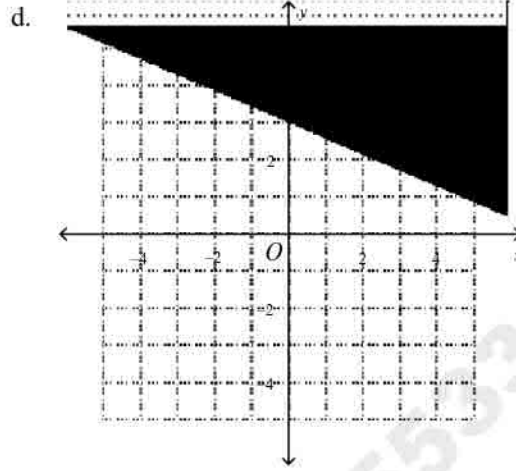
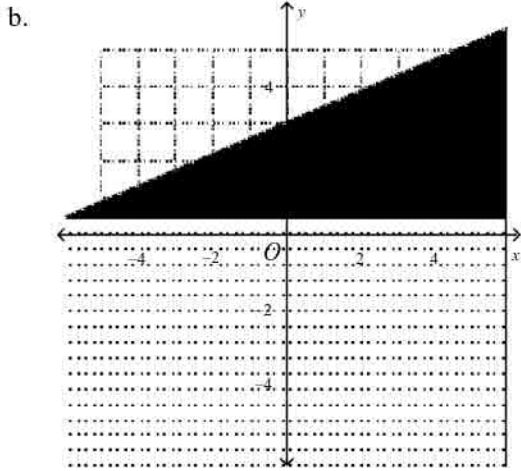

160.  $y > -x + 5$

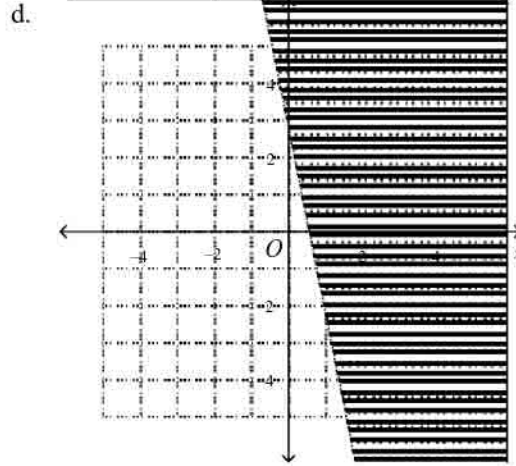
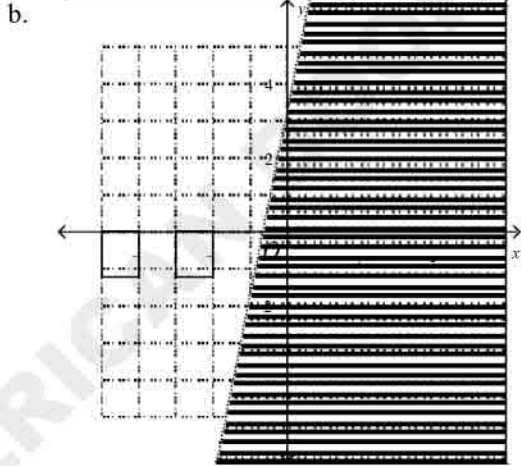
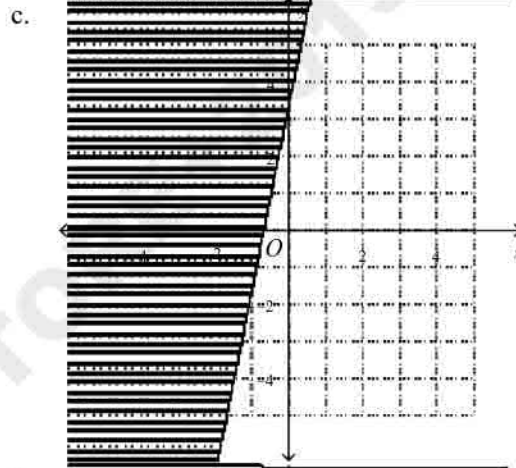
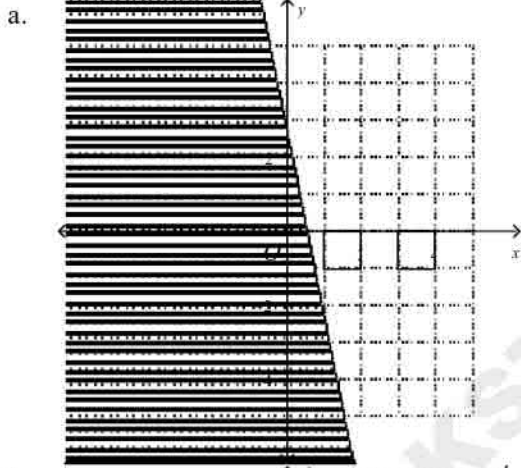

What is the graph of the inequality in the coordinate plane?

161.  $x \geq 4$

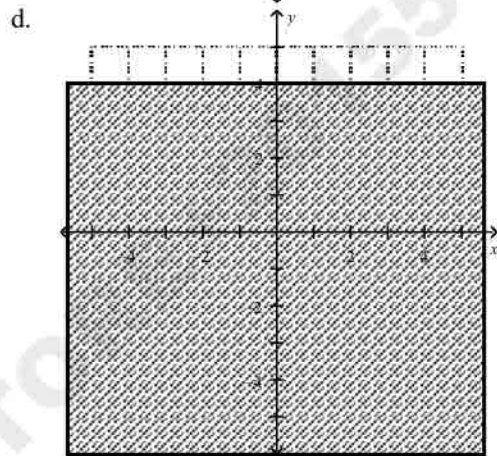
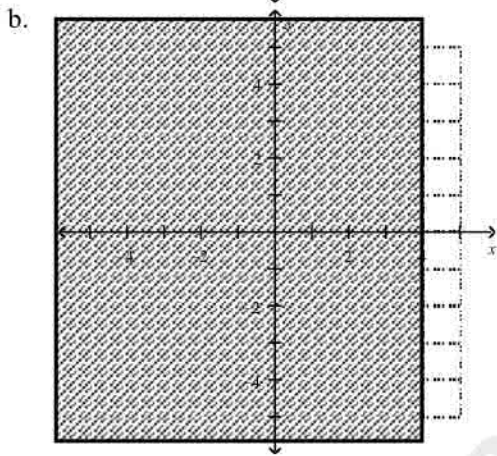
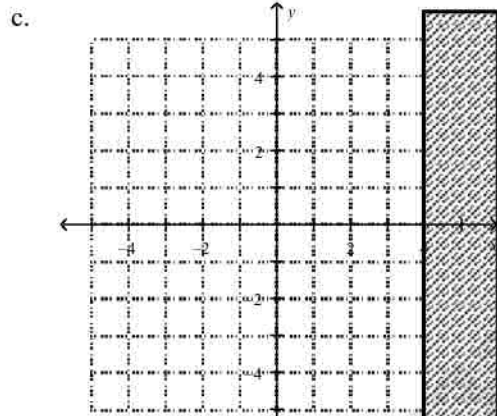
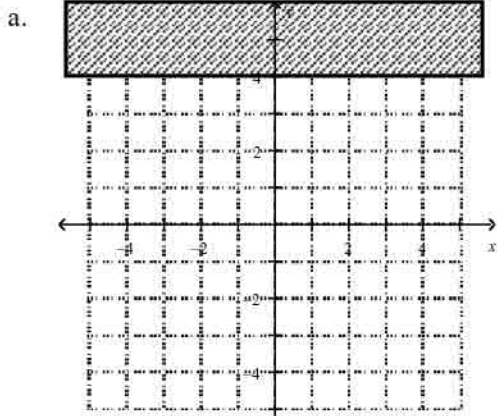

162.  $y < -2$

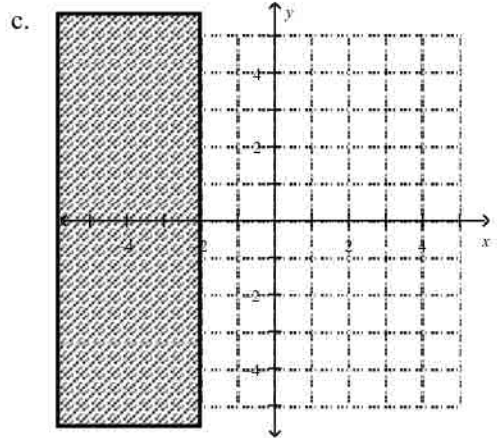
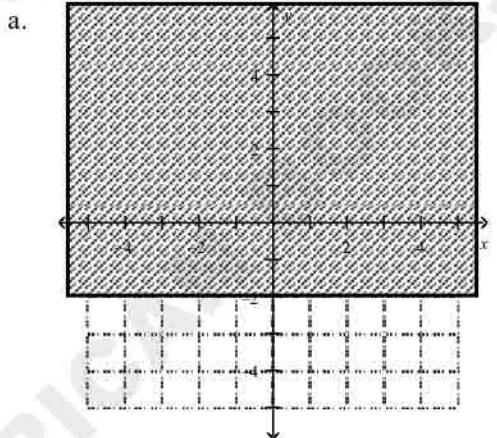

AMERICAN INSTITUTE FOR TEST PREP 889184

b.

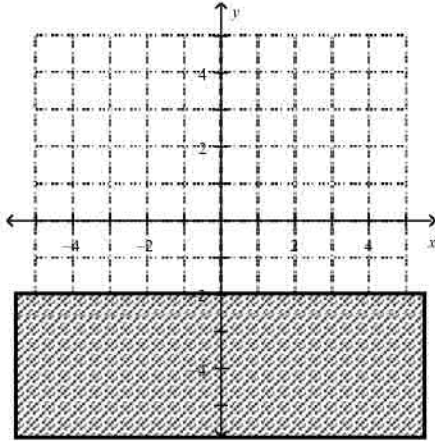

d.

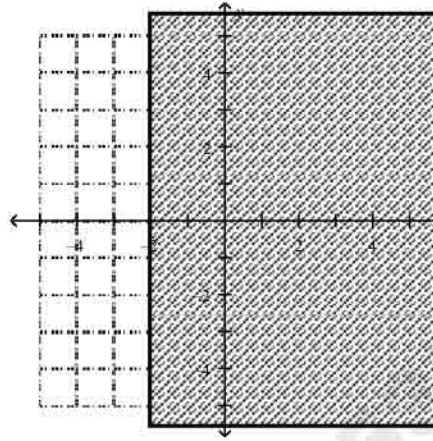

What is the simplified form of each expression?

163.  $(-4.2)^0$   
 a.  $-1$                       b.  $1$                       c.  $-4.2$                       d.  $0$
164.  $-(4)^{-2}$   
 a.  $-\frac{1}{-2^4}$                       b.  $4^2$                       c.  $\frac{1}{4^2}$                       d.  $-\frac{1}{4^2}$
165.  $(-3)^{-2}$   
 a.  $-\frac{1}{9}$                       b.  $9$                       c.  $\frac{1}{9}$                       d.  $6$
166.  $\frac{1}{a^{-5}}$   
 a.  $a^5$                       b.  $-a^5$                       c.  $5a$                       d.  $\frac{5}{a}$
167.  $\frac{3}{a^{-9}b}$   
 a.  $\frac{27a}{b}$                       b.  $\frac{3}{a^9b}$                       c.  $\frac{3}{ab^{-8}}$                       d.  $\frac{3a^9}{b}$
168. What is the value of  $4x^{-3}y^3$  for  $x = 3$  and  $y = -1$ ?  
 a.  $\frac{4}{729}$                       b.  $-\frac{4}{27}$                       c.  $-108$                       d.  $4(-3)^0$
169. What is the value of  $\frac{1}{2^{-2}x^{-3}y^5}$  for  $x = 2$  and  $y = -4$ ?  
 a.  $16$                       b.  $-4$                       c.  $-\frac{1}{32}$                       d.  $-16$
170. What is the value of  $\frac{y^{-5}}{x^{-3}}$  for  $x = 2$  and  $y = -4$ ?  
 a.  $\frac{10}{3}$                       b.  $128$                       c.  $-\frac{1}{128}$                       d.  $-128$

What is each expression written using each base only once?

- \_\_\_ 171.  $8^8 \cdot 8^4$   
 a.  $512^{12}$       b.  $8^{32}$       c.  $24^{12}$       d.  $8^{12}$
- \_\_\_ 172.  $(7.57)^{-4} \cdot (7.57)^4$   
 a. 8      b. 1      c. 0      d.  $7.57^8$
- \_\_\_ 173.  $(-5)^{-5} \cdot (-5)^6$   
 a. -5      b.  $5^{11}$       c. 1      d. 11
- \_\_\_ 174.  $7^{10} \cdot 7^{-4} \cdot 7^7$   
 a.  $7^{13}$       b.  $21^{13}$       c.  $7^{-280}$       d.  $343^{13}$

What is the simplified form of each expression?

- \_\_\_ 175.  $2b^{-1} \cdot 5b^{10}$   
 a.  $10b^9$       b.  $7b^9$       c.  $10b^{-10}$       d.  $7b^{-10}$
- \_\_\_ 176.  $-4x^3 \cdot 2y^{-2} \cdot 5y^5 \cdot x^{-8}$   
 a.  $\frac{x^2}{40y^3}$       b.  $\frac{40y^3}{x^5}$       c.  $\frac{2x^5}{5y^3}$       d.  $\frac{5y^3}{2x}$

What is the simplified form of the expression?

- \_\_\_ 177.  $(p^6)^2$   
 a.  $p^{12}$       b.  $2p^{12}$       c.  $p^8$       d.  $p^{36}$
- \_\_\_ 178.  $(n^{-2})^4$   
 a.  $\frac{1}{n^8}$       b.  $\frac{1}{n^{16}}$       c.  $n^8$       d.  $\frac{x}{8}$
- \_\_\_ 179.  $m^7(m^2)^{-9}$   
 a.  $m^{11}$       b.  $m^{-49}$       c.  $m^5$       d.  $m^{-11}$

What is the simplified form of each expression?

- \_\_\_ 180.  $(3xy^3)^2(xy)^6$   
 a.  $9x^8y^{12}$       b.  $3x^8y^{12}$       c.  $2x^3y^{12}$       d.  $9x^8y^9$
- \_\_\_ 181.  $(-5g^4h^6)^2(g^5h^5)^5$   
 a.  $\frac{g^{33}h^{37}}{25}$       b.  $-25g^{33}h^{37}$       c.  $25g^{33}h^{37}$       d.  $25g^{16}h^{18}$

- \_\_\_ 182. Suppose a spherical asteroid has a radius of approximately  $2.4 \times 10^3$  m. Use the formula  $\left(\frac{4}{3}\right)\pi r^3$  to find the approximate volume of the asteroid.

- a.  $5.79 \times 10^7 \text{ m}^3$       c.  $5.79 \times 10^{10} \text{ m}^3$   
 b.  $3.71 \times 10^{12} \text{ m}^3$       d.  $3.02 \times 10^4 \text{ m}^3$

What is the simplified form of each expression?

183.  $\frac{t^{11}}{t^2}$   
 a.  $t^{13}$                       b.  $t^{22}$                       c.  $\frac{1}{t^9}$                       d.  $t^9$

184.  $\frac{y^{-2}}{y^5}$   
 a.  $\frac{1}{y^3}$                       b.  $y^7$                       c.  $\frac{1}{y^7}$                       d.  $y^3$

185.  $\frac{c^9 d^{-7}}{c^{14} d^{-10}}$   
 a.  $\frac{d^2}{d^4}$                       b.  $c^5 d^3$                       c.  $\frac{d^3}{c^5}$                       d.  $c^2 d^4$

What is the simplified form of the expression?

186.  $\left(\frac{4k^4}{7c^3}\right)^3$   
 a.  $28k^{12}c^9$                       b.  $\frac{64k^{12}}{343c^9}$                       c.  $\frac{12k^{12}}{21c^9}$                       d.  $\frac{64k^{12}}{7c}$

187.  $\left(\frac{m^{-1}m^5}{m^{-2}}\right)^{-3}$   
 a.  $\frac{3m^4}{m^{-2}}$                       b.  $\frac{1}{m^{18}}$                       c.  $m^{18}$                       d.  $-m^{216}$

188.  $\left(\frac{3x^5}{8j^4}\right)^{-3}$   
 a.  $24x^{15}j^{12}$                       b.  $\frac{512j^{12}}{27x^{15}}$                       c.  $\frac{-24x^{15}}{9j^{12}}$                       d.  $\frac{512x^{15}}{8j}$

189. Suppose a population of 40 crickets doubles in size every month. The function  $f(x) = 40 \cdot 2^x$  gives the population after  $x$  months. How many crickets will there be after 3 years?  
 a. 2,880 crickets                      c. 320 crickets  
 b. 240 crickets                      d. 2,748,779,069,440 crickets

190. Suppose an investment of \$3,800 doubles in value every decade. The function  $f(x) = 3,800 \cdot 2^x$  gives the value of the investment after  $x$  decades. How much is the investment worth after 2 decades?  
 a. \$152,000                      c. \$76,000  
 b. \$15,200                      d. \$15,200

What is the graph of the function?

191.  $y = 3 \cdot 5^x$

a.

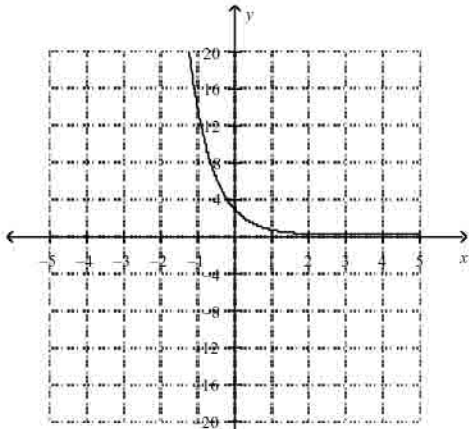

c.

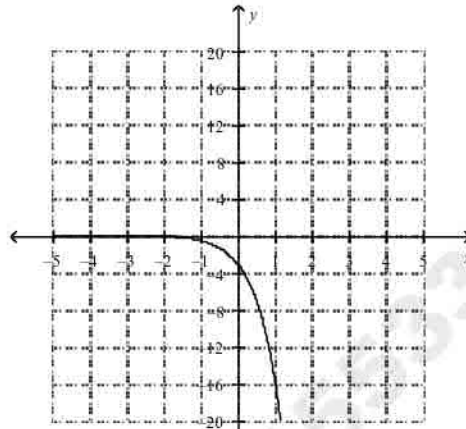

b.

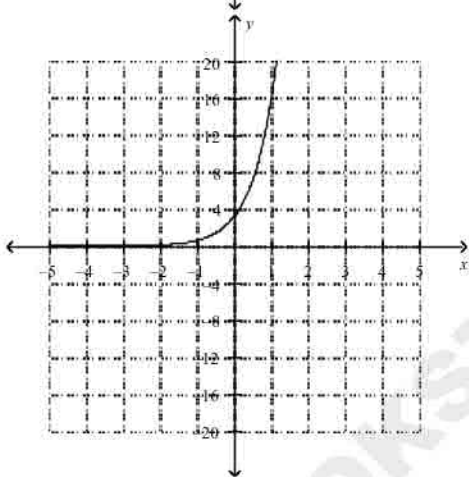

d.

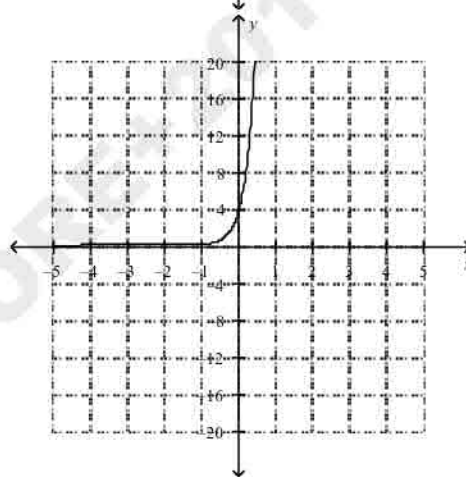

192.  $y = -4 \cdot 5^x$

a.

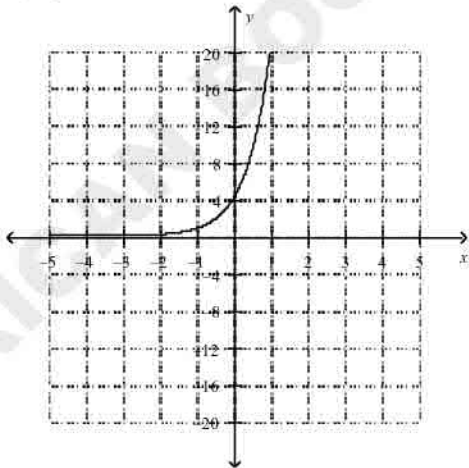

c.

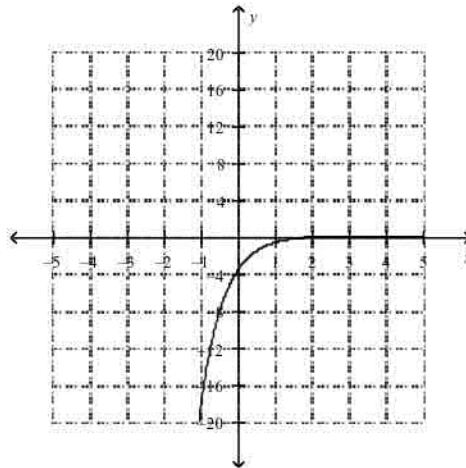

b.

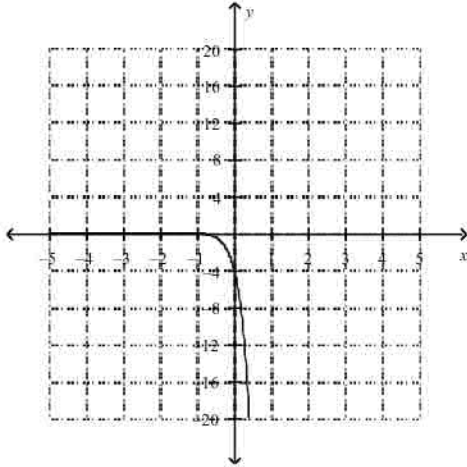

d.

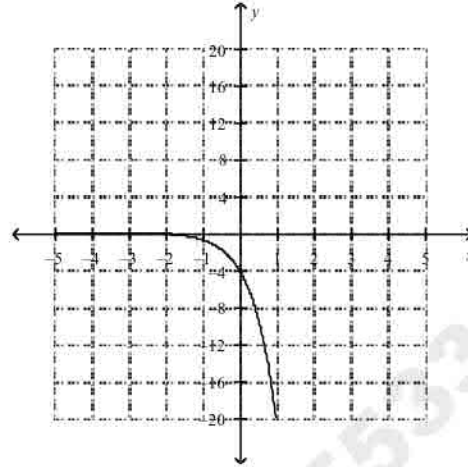

193.  $y = \frac{1}{5} \cdot 2^x$

a.

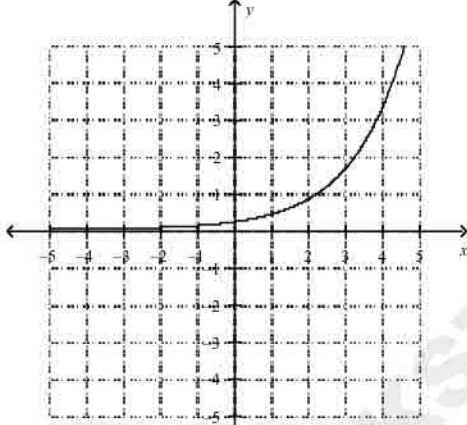

c.

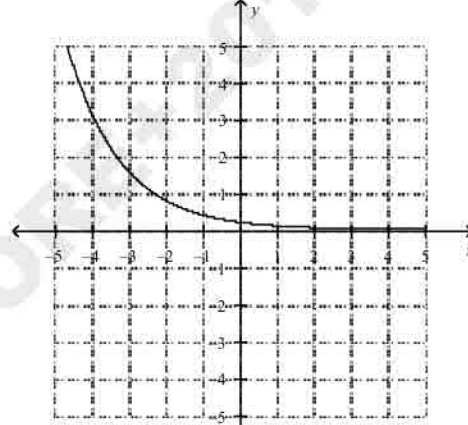

b.

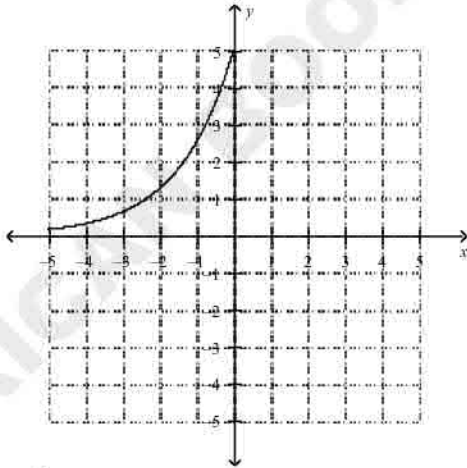

d.

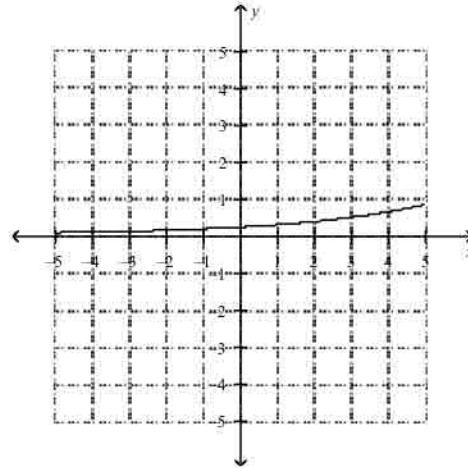

194.  $y = -\frac{1}{5} \cdot 4^x$

AMERICANSTATISTOR 1553389184

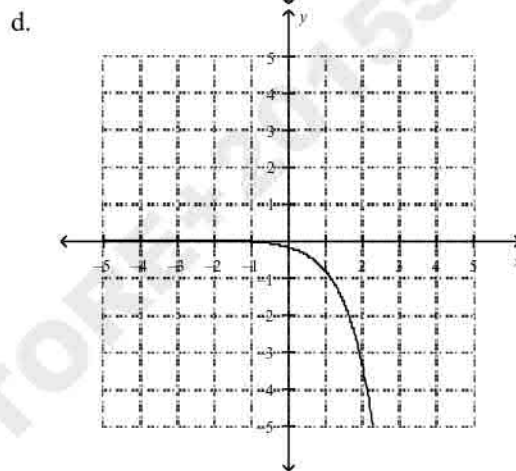
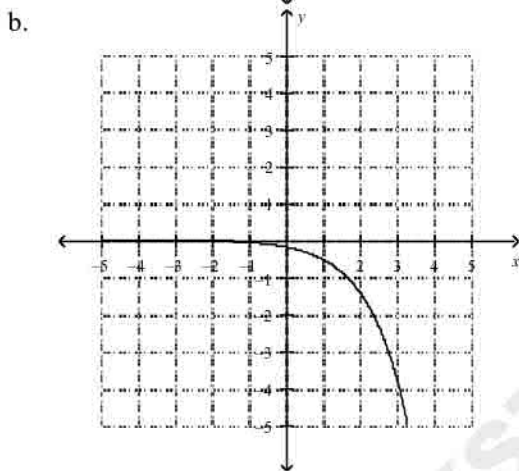
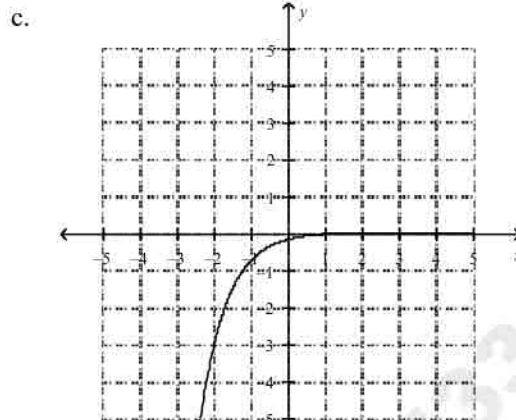
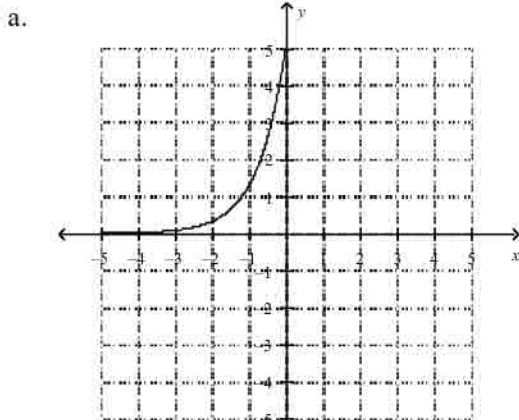

195. Suppose the population of a town is 8,600 and is growing 3% each year. Predict the population after 3 years.

- a. about 77,400 people
- b. about 9,397 people
- c. about 26574 people
- d. about 232,200 people

What is the degree of each monomial?

196.  $7m^6n^5$
- a. 5
  - b. 11
  - c. 6
  - d. 7

Simplify the sum.

197.  $(2u^3 + 6u^2 + 3) + (2u^3 - 7u + 6)$
- a.  $9 - 7u + 6u^2 + 4u^3$
  - b.  $0u^3 + 6u^2 - 7u + 9$
  - c.  $0u^3 - 7u^2 + 6u - 9$
  - d.  $4u^3 + 6u^2 - 7u + 9$

Simplify the difference.

198.  $(-7x - 5x^4 + 5) - (-7x^4 - 5 - 9x)$

- a.  $2x^4 + 2x + 8$   
 b.  $-14x^4 + 10x + 10$   
 c.  $-14x^4 - 10x + 10$   
 d.  $2x^4 + 2x + 10$

**Simplify the product.**

199.  $2n(n^2 + 3n + 4)$   
 a.  $2n^3 + 6n^2 + 8n$   
 b.  $2n^3 + 3n + 4$   
 c.  $2n^3 + 6n + 8$   
 d.  $n^2 + 5n + 4$

**Factor the polynomial.**

200.  $2x^3 + 4x^2 + 8x$   
 a.  $2x(x^2 + 2x + 4)$   
 b.  $2x(x + 2)(x + 4)$   
 c.  $2x(x^2 + 2x + 8)$   
 d.  $2x^3 + 4x^2 + 8x$
201.  $54c^3d^4 + 9c^4d^2$   
 a.  $9c^3d^2(d^2 + 6c)$   
 b.  $9c^3d^2(6d^2 + c)$   
 c.  $9c^4d^2(d^2 + 6)$   
 d.  $9c^4d^2(6d^2 + 1)$

**Simplify the product using the distributive property.**

202.  $(3h - 7)(3h - 6)$   
 a.  $9h^2 + 3h - 42$   
 b.  $9h^2 - 3h - 42$   
 c.  $9h^2 - 39h + 42$   
 d.  $9h^2 + 39h + 42$

203. A sphere has a radius of  $2x + 5$ . Which polynomial in standard form best describes the total surface area of the sphere? Use the formula  $S = 4\pi r^2$  for the surface area of a sphere.  
 a.  $16\pi x^2 + 80\pi x + 100\pi$   
 b.  $16\pi x^2 - 80\pi x - 100\pi$   
 c.  $16\pi x^2 + 80\pi x - 100\pi$   
 d.  $16\pi x^2 - 80\pi x + 100\pi$

**What is a simpler form of the expression?**

204.  $(2n^2 + 5n + 3)(4n - 5)$   
 a.  $8n^3 + 10n^2 - 13n - 15$   
 b.  $8n^3 + 30n^2 - 37n - 15$   
 c.  $8n^3 - 10n^2 + 37n - 15$   
 d.  $8n^3 + 13n^2 - 10n - 15$

**What is a simpler form of each product?**

205.  $(2x - 6)^2$   
 a.  $4x^2 - 24x + 36$   
 b.  $4x^2 - 8x + 36$   
 c.  $4x^2 + 36$   
 d.  $4x^2 - 12x + 36$

206. A square painting is surrounded by a frame. The outside edges of the frame are  $x$  inches in length and there is a 4-inch border between the painting and the frame. What is the total area of the border?

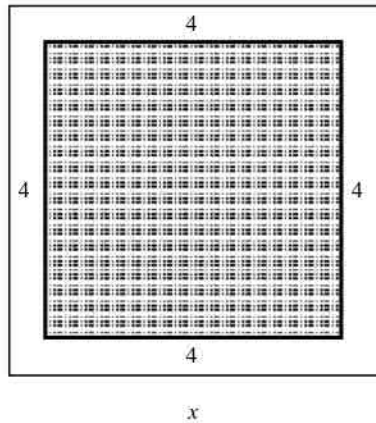

- a.  $16x - 64$   
b.  $-16x - 64$

- c.  $x^2 + 16x + 64$   
d.  $-8x + 16$

207. What is  $58^{27}$ ? Use mental math.

- a. 2,500                      b. 1,764

- c. 2,964                      d. 3,364

**What is a simpler form of the following expressions?**

208.  $(2n + 2)(2n - 2)$

- a.  $4n^2 - 4$   
b.  $4n^2 - 4n - 4$

- c.  $4n^2 + 2n - 4$   
d.  $4n^2 + 4n - 4$

209. What is  $55 \cdot 45$ ?

- a. 2515  
b. 2475

- c. 2535  
d. 2465

210. What is  $109 \cdot 91$ ?

- a. 10099  
b. 10063

- c. 9901  
d. 9919

**What is the factored form of the following expressions?**

211.  $w^2 + 18w + 77$

- a.  $(w - 7)(w + 11)$   
b.  $(w - 7)(w - 11)$

- c.  $(w + 7)(w + 11)$   
d.  $(w + 1)(w + 77)$

212.  $d^2 + 16d + 63$

- a.  $(d - 7)(d - 9)$   
b.  $(d + 7)(d - 9)$

- c.  $(d + 7)(d + 9)$   
d.  $(d - 7)(d + 9)$

213.  $d^2 - 19d + 90$

- a.  $(d + 10)(d + 9)$   
b.  $(d - 10)(d - 9)$

- c.  $(d - 10)(d + 9)$   
d.  $(d + 10)(d - 9)$

214.  $d^2 - 14d + 45$

- a.  $(d + 9)(d + 5)$   
b.  $(d + 9)(d - 5)$

- c.  $(d - 9)(d + 5)$   
d.  $(d - 9)(d - 5)$

215.  $d^2 + 2d - 48$

- a.  $(d + 6)(d + 8)$   
b.  $(d + 6)(d - 8)$

- c.  $(d - 6)(d + 8)$   
d.  $(d - 6)(d - 8)$



What are the coordinates of the vertex of the graph? Is it a maximum or minimum?

226.

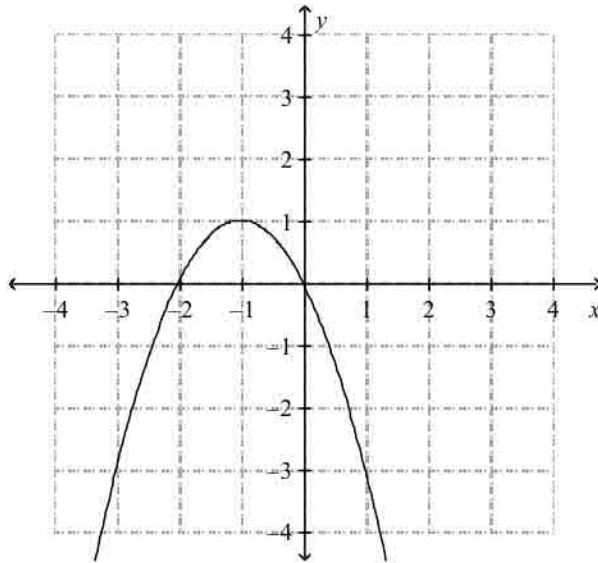

- a.  $(-1, 1)$ ; minimum  
 b.  $(1, -1)$ ; maximum  
 c.  $(1, -1)$ ; minimum  
 d.  $(-1, 1)$ ; maximum

227.

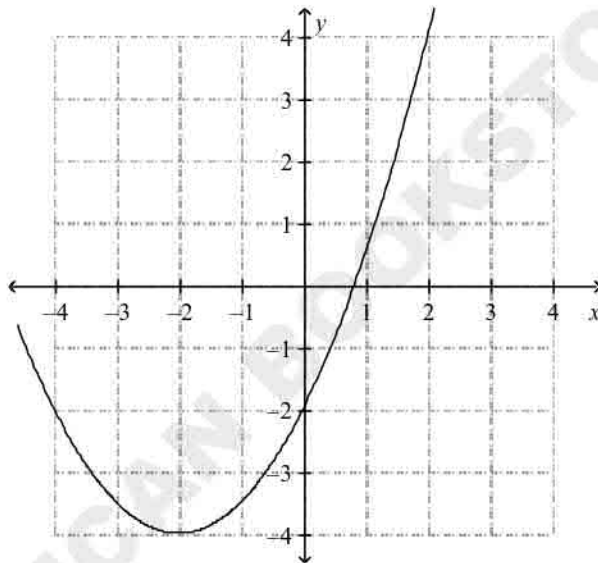

- a.  $(-4, -2)$ ; minimum  
 b.  $(-2, -4)$ ; maximum  
 c.  $(-2, -4)$ ; minimum  
 d.  $(-4, -2)$ ; maximum

Order the group of quadratic functions from widest to narrowest graph.

228.

$y = 3x^2, y = x^2, y = 2x^2$

- a.  $y = 3x^2, y = 2x^2, y = x^2$   
 b.  $y = 2x^2, y = x^2, y = 3x^2$   
 c.  $y = x^2, y = 2x^2, y = 3x^2$   
 d.  $y = x^2, y = 3x^2, y = 2x^2$

229.  $y = -4x^2$ ,  $y = -3x^2$ ,  $y = -5x^2$
- a.  $y = -3x^2$ ,  $y = -5x^2$ ,  $y = -4x^2$       c.  $y = -3x^2$ ,  $y = -4x^2$ ,  $y = -5x^2$   
 b.  $y = -5x^2$ ,  $y = -4x^2$ ,  $y = -3x^2$       d.  $y = -4x^2$ ,  $y = -3x^2$ ,  $y = -5x^2$
230. How is the graph of  $y = 3x^2 + 3$  different from the graph of  $y = 3x^2$ ?
- a. It is shifted 3 unit(s) up.      c. It is shifted 3 unit(s) left.  
 b. It is shifted 3 unit(s) down.      d. It is shifted 3 unit(s) right.
231. How is the graph of  $y = -4x^2 - 5$  different from the graph of  $y = -4x^2$ ?
- a. It is shifted 5 unit(s) right.      c. It is shifted 5 unit(s) up.  
 b. It is shifted 5 unit(s) left.      d. It is shifted 5 unit(s) down.
232. If an object is dropped from a height of 116 feet, the function  $h(t) = -16t^2 + 116$  gives the height of the object after  $t$  seconds. When will the object hit the ground?
- a. 1.35 s      c. 10.77 s  
 b. 5.39 s      d. 2.69 s

**Graph the function. Identify the vertex and axis of symmetry.**

233.  $f(x) = x^2 + 4x + 1$

a.

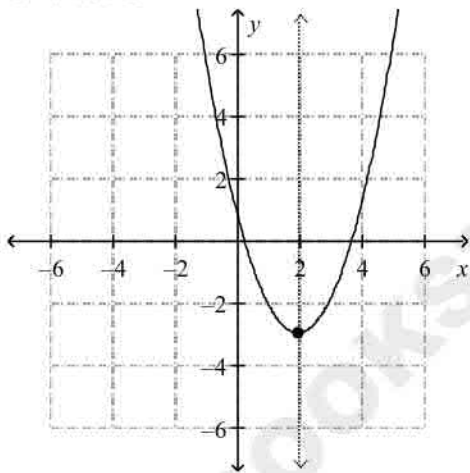

axis of symmetry:  $x = 2$   
 vertex:  $(2, -3)$

b.

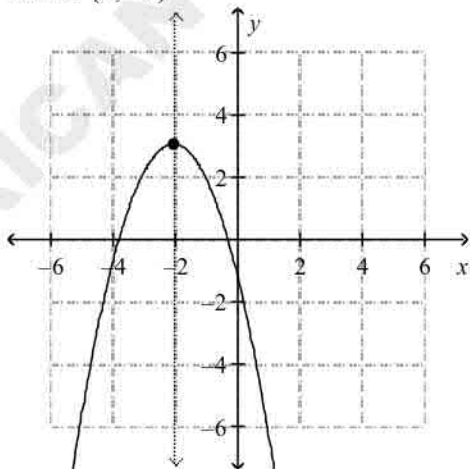

c.

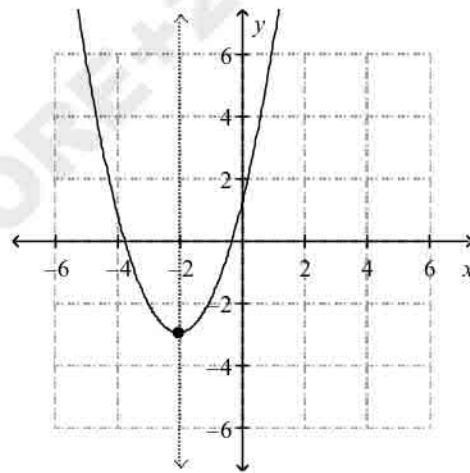

axis of symmetry:  $x = -2$   
 vertex:  $(-2, -3)$

d.

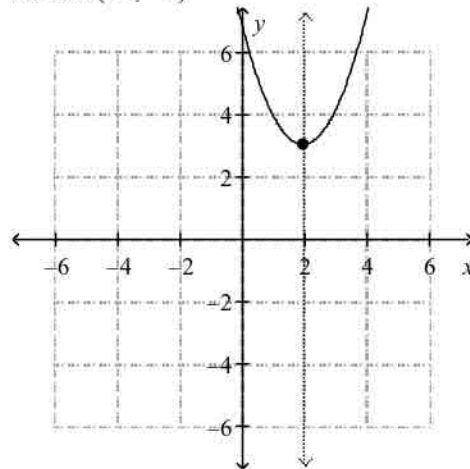

axis of symmetry:  $x = -2$   
vertex:  $(-2, 3)$

axis of symmetry:  $x = 2$   
vertex:  $(2, 3)$

234.  $f(x) = -2x^2 + 2x - 1$

a.

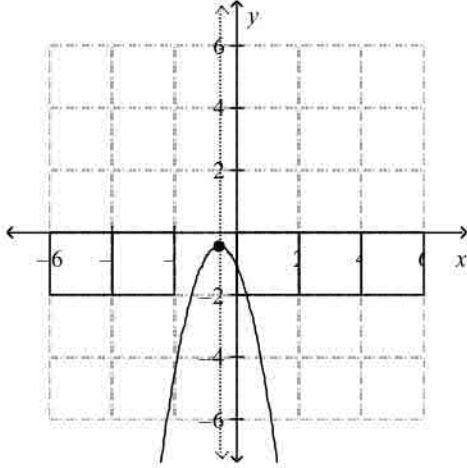

c.

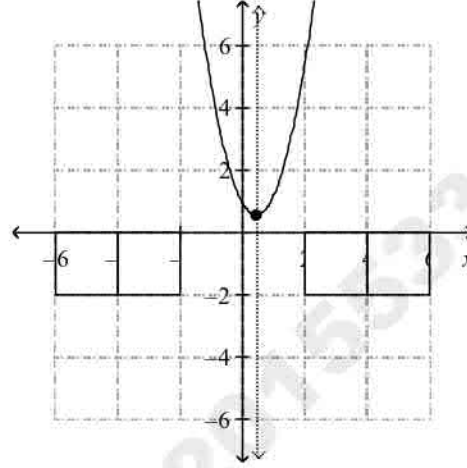

axis of symmetry:  $x = -0.5$   
vertex:  $(-0.5, -0.5)$

axis of symmetry:  $x = 0.5$   
vertex:  $(0.5, 0.5)$

b.

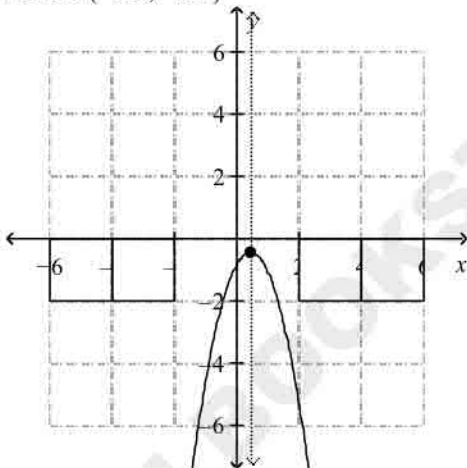

d.

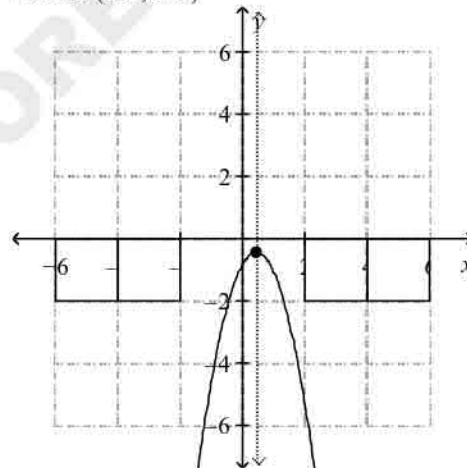

axis of symmetry:  $x = 0.5$   
vertex:  $(0.5, -0.5)$

axis of symmetry:  $x = 0.5$   
vertex:  $(0.5, 0.5)$

**Solve the equation using square roots.**

235.  $x^2 - 9 = 0$

- a.  $-3, 3$   
b.  $-9, 9$

- c.  $-\sqrt{3}, \sqrt{3}$   
d. no real number solutions

**Solve the equation using the Zero-Product Property.**

236.  $(x - 2)(x + 7) = 0$

- a.  $2, -7$

- c.  $-1, 1$

237.  $(2x-4)(2x-1) = 0$

- a.  $2, -\frac{1}{2}$       d.  $-2, -7$   
 b.  $2, \frac{1}{2}$       c.  $-2, 2$   
 c.  $2, -\frac{1}{2}$       d.  $-2, \frac{1}{2}$

238. What is the value of  $c$  such that  $x^2 + 14x + c$  is a perfect-square trinomial?

- a. 7      b. 98      c. 196      d. 49

239. What is the value of  $c$  such that  $x^2 - 11x + c$  is a perfect-square trinomial?

- a.  $-\frac{11}{2}$       b. 121      c.  $\frac{121}{2}$       d.  $\frac{121}{4}$

240. Which kind of function best models the data in the table? Use differences or ratios.

$x$	$y$
0	-1
1	-1.5
2	-2
3	-2.5
4	-3

- a. linear      c. exponential  
 b. quadratic      d. none of these

241. Which kind of function best models the data in the table? Use differences or ratios.

$x$	$y$
0	1.6
1	3.2
2	6.4
3	12.8
4	25.6

- a. linear      c. exponential  
 b. quadratic      d. none of these

242. Write an equation to model the data in the table.

$x$	$y$
0	3
1	-0.5
2	-4
3	-7.5
4	-11

- a.  $y = -3.5 \cdot 3^x$       c.  $y = -3.5x + 3$   
 b.  $y = 3x$       d.  $y = -3.5x^2 + 3$

243. Write an equation to model the data in the table.

$x$	$y$
-----	-----

0	-3.8
1	-19
2	-95
3	-475
4	-2375

- a.  $y = -3.8 \cdot 5^x$   
 b.  $y = -3.8x + 5$

- c.  $y = -3.8x^2 + 5$   
 d.  $y = 5x$

What are the solutions of the system? Solve by graphing.

244.  $y = x^2 - 3x + 3$   
 $y = 2x - 3$

a.

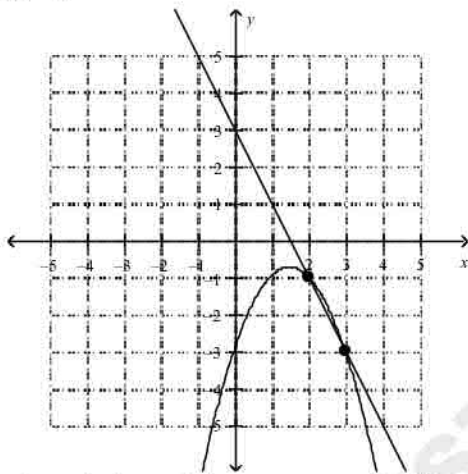

The solutions of the system are  $(2, -1)$  and  $(3, -3)$ .

b.

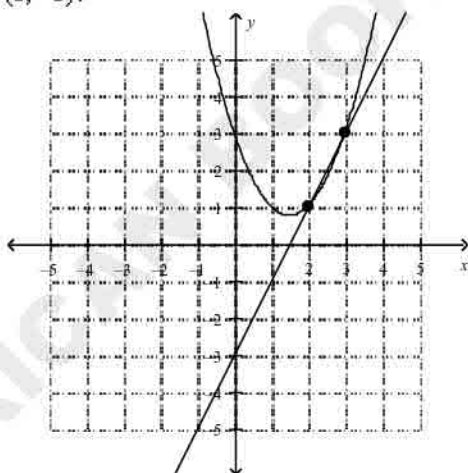

The solutions of the system are  $(2, 1)$  and  $(3, 3)$ .

245.  $y = x^2 - 2x - 1$   
 $y = -2$

c.

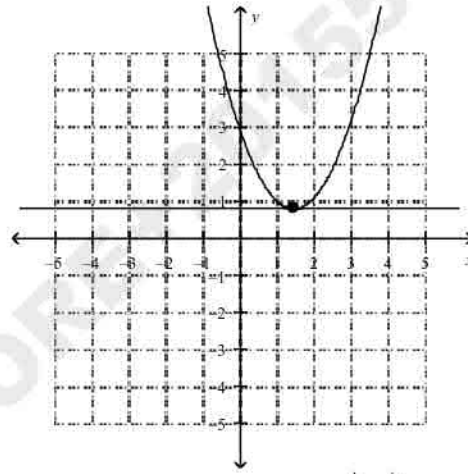

The solution of the system is  $(\frac{3}{2}, \frac{3}{4})$ .

d.

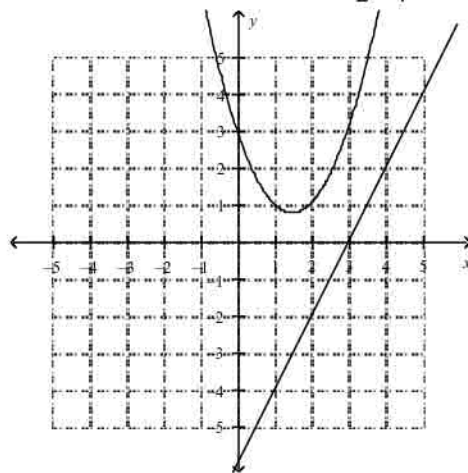

The system has no solution.

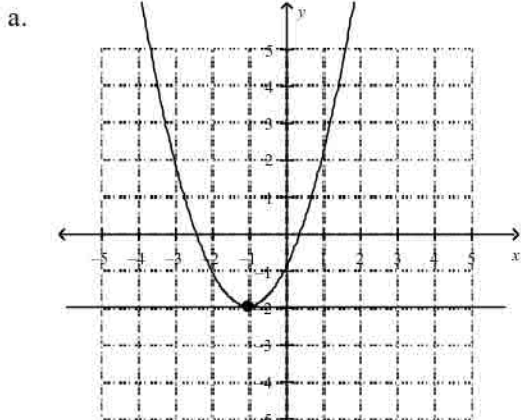

The solution of the system is  $(-1, -2)$ .

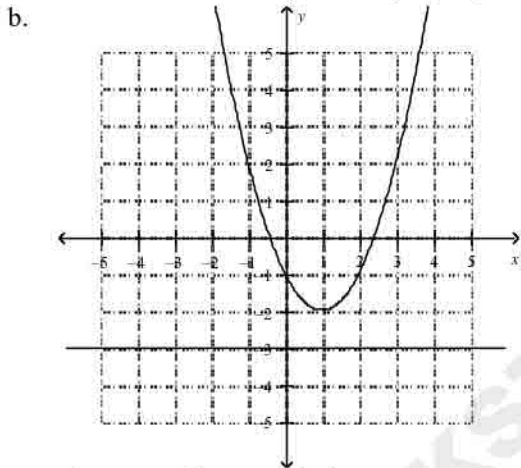

The system has no solution.

246.  $y = x^2 - 3x - 2$

$y = -2x - 5$

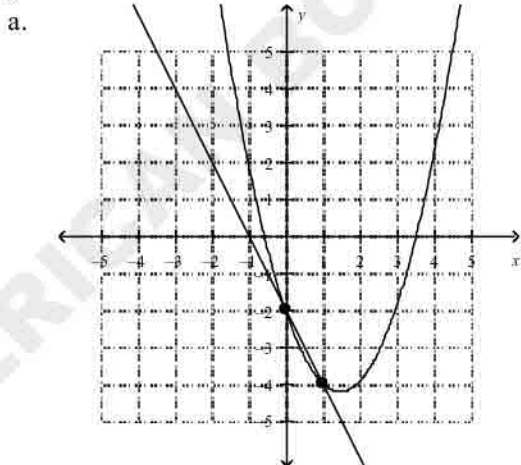

The solutions of the system are  $(0, -2)$  and  $(1, -4)$ .

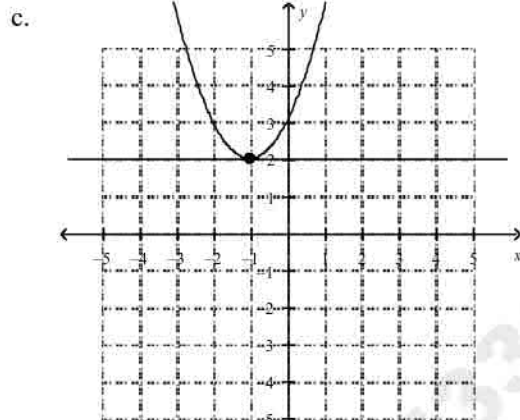

The solution of the system is  $(-1, 2)$ .

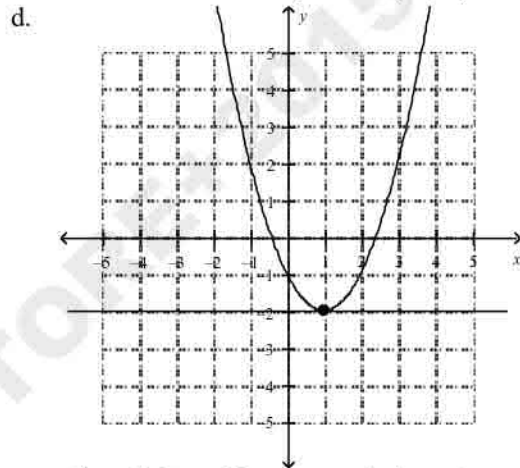

The solution of the system is  $(1, -2)$ .

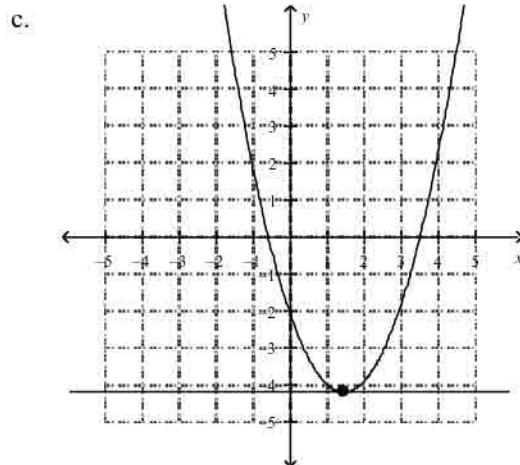

The solution of the system is  $(\frac{3}{2}, -\frac{17}{4})$ .

b.

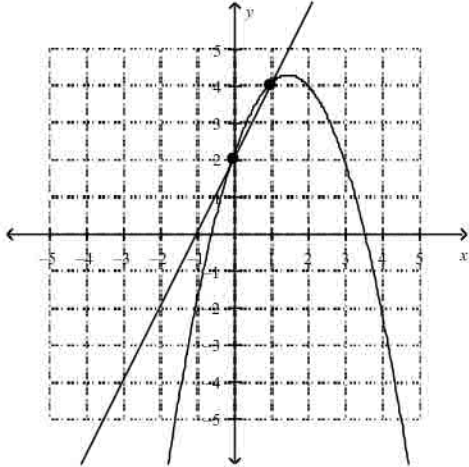

The solutions of the system are  $(0, 2)$  and  $(1, 4)$ .

d.

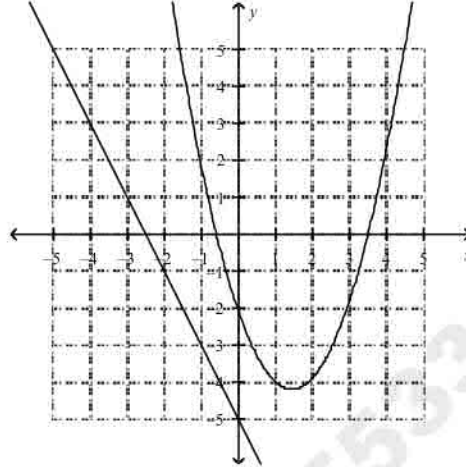

The system has no solution.

**Answer Section**

**MULTIPLE CHOICE**

1. ANS: B
2. ANS: D
3. ANS: B
4. ANS: B
5. ANS: D
6. ANS: B
7. ANS: B
8. ANS: B
9. ANS: B
10. ANS: A
11. ANS: A
13. ANS: A
14. ANS: A
15. ANS: C
16. ANS: C
17. ANS: D
18. ANS: C
19. ANS: D
20. ANS: C
21. ANS: B
22. ANS: D
23. ANS: A
25. ANS: D
26. ANS: A
27. ANS: B
28. ANS: D
29. ANS: A
30. ANS: A
31. ANS: D
32. ANS: A
33. ANS: D
34. ANS: D
35. ANS: D
36. ANS: B
37. ANS: A
38. ANS: A
39. ANS: B
40. ANS: C
41. ANS: C
42. ANS: B

ALL QUESTIONS HAVE BEEN COLLECTED FROM PEARSON

43. ANS: D
44. ANS: D
45. ANS: D
46. ANS: D
47. ANS: D
48. ANS: A
49. ANS: A
50. ANS: C
51. ANS: C
52. ANS: D
53. ANS: C
54. ANS: D
55. ANS: C
56. ANS: B
57. ANS: D
58. ANS: B
59. ANS: C
60. ANS: B
61. ANS: D
62. ANS: D
63. ANS: D
64. ANS: D
65. ANS: A
66. ANS: A
67. ANS: D
68. ANS: C
69. ANS: B
70. ANS: C
71. ANS: D
72. ANS: C
73. ANS: A
74. ANS: C
75. ANS: C
76. ANS: D
77. ANS: A
78. ANS: A
79. ANS: C
80. ANS: C
81. ANS: C
82. ANS: D
83. ANS: B
84. ANS: D
85. ANS: A
86. ANS: D
87. ANS: C
88. ANS: B
89. ANS: C

ALL QUESTIONS HAVE BEEN COLLECTED FROM PEARSON

- 90. ANS: C
- 91. ANS: A
- 92. ANS: C
- 93. ANS: D
- 94. ANS: A
- 95. ANS: C
- 96. ANS: D
- 97. ANS: B
- 98. ANS: D
- 99. ANS: A
- 101. ANS: D
- 102. ANS: C
- 103. ANS: A
- 104. ANS: D
- 105. ANS: A
- 106. ANS: B
- 107. ANS: C
- 108. ANS: B
- 109. ANS: C
- 110. ANS: B
- 111. ANS: B
- 112. ANS: B
- 113. ANS: C
- 114. ANS: A
- 115. ANS: D
- 116. ANS: B
- 117. ANS: B
- 118. ANS: C
- 119. ANS: D
- 120. ANS: D
- 121. ANS: C
- 122. ANS: A
- 123. ANS: C
- 124. ANS: A
- 125. ANS: D
- 126. ANS: A
- 127. ANS: B
- 128. ANS: C
- 129. ANS: A
- 130. ANS: B
- 131. ANS: B
- 132. ANS: C
- 133. ANS: D
- 134. ANS: D
- 135. ANS: B
- 136. ANS: C
- 137. ANS: C

ALL QUESTIONS HAVE BEEN COLLECTED FROM PEARSON

- 138. ANS: B
- 139. ANS: C
- 140. ANS: A
- 141. ANS: A
- 142. ANS: B
- 143. ANS: A
- 144. ANS: A
- 145. ANS: B
- 146. ANS: C
- 147. ANS: A
- 148. ANS: C
- 149. ANS: A
- 150. ANS: B
- 151. ANS: A
- 152. ANS: A
- 153. ANS: D
- 154. ANS: D
- 155. ANS: D
- 156. ANS: D
- 157. ANS: B
- 158. ANS: D
- 159. ANS: A
- 160. ANS: D
- 161. ANS: C
- 162. ANS: B
- 163. ANS: B
- 164. ANS: D
- 165. ANS: C
- 166. ANS: A
- 167. ANS: D
- 168. ANS: B
- 169. ANS: C
- 170. ANS: C
- 171. ANS: D
- 172. ANS: B
- 173. ANS: A
- 174. ANS: A
- 175. ANS: A
- 176. ANS: B
- 177. ANS: A
- 178. ANS: A
- 179. ANS: D
- 180. ANS: A
- 181. ANS: C
- 182. ANS: C
- 183. ANS: D
- 184. ANS: C

ALL QUESTIONS HAVE BEEN COLLECTED FROM PEARSON

- 185. ANS: C
- 186. ANS: B
- 187. ANS: B
- 188. ANS: B
- 189. ANS: D
- 190. ANS: B
- 191. ANS: B
- 192. ANS: D
- 193. ANS: A
- 194. ANS: D
- 195. ANS: B
- 196. ANS: B
- 197. ANS: D
- 198. ANS: D
- 199. ANS: A
- 200. ANS: A
- 201. ANS: B
- 202. ANS: C
- 203. ANS: A
- 204. ANS: A
- 205. ANS: A
- 206. ANS: A
- 207. ANS: D
- 208. ANS: A
- 209. ANS: B
- 210. ANS: D
- 211. ANS: C
- 212. ANS: C
- 213. ANS: B
- 214. ANS: D
- 215. ANS: C
- 216. ANS: A
- 217. ANS: A
- 218. ANS: D
- 219. ANS: B
- 220. ANS: D
- 221. ANS: C
- 222. ANS: A
- 223. ANS: B
- 224. ANS: D
- 225. ANS: D
- 226. ANS: D
- 227. ANS: C
- 228. ANS: C
- 229. ANS: C
- 230. ANS: A
- 231. ANS: D

ALL QUESTIONS HAVE BEEN COLLECTED FROM PEARSON

- 232. ANS: D
- 233. ANS: C
- 234. ANS: B
- 235. ANS: A
- 236. ANS: A
- 237. ANS: B
- 238. ANS: D
- 239. ANS: D
- 240. ANS: A
- 241. ANS: C
- 242. ANS: C
- 243. ANS: A
- 244. ANS: B
- 245. ANS: D
- 246. ANS: D

AMERICAN BOOKSTORE+201553389184

**Multiple Choice**

Identify the choice that best completes the statement or answers the question.

What is the length of the hypotenuse of the right triangle shown?

1.

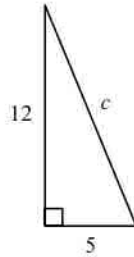

- a. 17                      b. 13                      c. 7                      d. 4.1

What is the side length  $b$  in the triangle below?

2.

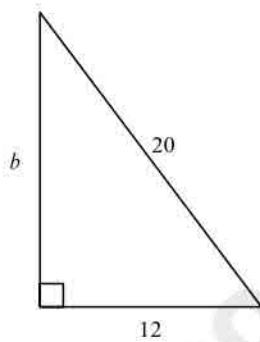

- a. 8                      b. 16                      c. 2.8                      d. 23.3

Can the set of lengths be the side lengths of a right triangle?

3. 18 m, 24 m, 30 m  
 a. yes                      b. no
4. 7 ft, 12 ft, 17 ft  
 a. no                      b. yes

Simplify the radical expression.

5.  $\sqrt{12h^4}$   
 a.  $2\sqrt{3h^4}$                       c.  $2h^2\sqrt{3}$   
 b.  $h\sqrt{6}$                       d.  $4\sqrt{3h^4}$

6.  $\sqrt{20h^6k^4}$   
 a.  $4\sqrt{5h^6k^4}$   
 b.  $2\sqrt{5h^6k^4}$   
 c.  $2h^3k^2\sqrt{5}$   
 d.  $hk\sqrt{10}$

7.  $2\sqrt{10} \cdot 3\sqrt{12}$   
 a.  $12\sqrt{60}$   
 b.  $5\sqrt{120}$   
 c.  $12\sqrt{30}$   
 d.  $6\sqrt{120}$

8.  $\sqrt{14q} \cdot 2\sqrt{4q}$   
 a.  $3\sqrt{56q^2}$   
 b.  $4q\sqrt{14}$   
 c.  $2\sqrt{56q^2}$   
 d.  $4\sqrt{14q^2}$

Simplify the radical expression.

9.  $\sqrt{\frac{80w^3}{9}}$   
 a.  $\frac{w\sqrt{80w}}{3}$   
 b.  $\frac{4w\sqrt{5w}}{3}$   
 c.  $\frac{\sqrt{80w^3}}{3}$   
 d.  $3\sqrt{w^3}$

10.  $\sqrt{\frac{10}{121}}$   
 a.  $\frac{\sqrt{10}}{61}$   
 b.  $11\sqrt{10}$   
 c.  $\frac{\sqrt{10}}{11}$   
 d.  $\frac{10}{11}$

11.  $\sqrt{\frac{63x^{15}y^9}{7xy^{11}}}$   
 a.  $\frac{8x^7y^4\sqrt{xy}}{\sqrt{7xy^{11}}}$   
 b.  $\frac{3x^7}{y}$   
 c.  $\frac{9x^7}{y}$   
 d.  $9x^7y$

Simplify the radical expression by rationalizing the denominator.

12.  $\frac{3}{\sqrt{11}}$   
 a.  $3\sqrt{11}$   
 b.  $\frac{3\sqrt{11}}{11}$   
 c.  $11\sqrt{3}$   
 d.  $\frac{\sqrt{121}}{11}$

Simplify the expression.

13.  $5\sqrt{2} + \sqrt{18}$   
 a.  $8\sqrt{2}$   
 b.  $6\sqrt{18}$   
 c.  $14\sqrt{2}$   
 d.  $8\sqrt{18}$

14.  $7\sqrt{7} - 2\sqrt{28}$   
 a.  $3\sqrt{28}$   
 b.  $-\sqrt{7}$   
 c.  $5\sqrt{28}$   
 d.  $3\sqrt{7}$



d. no solution

Match the function with its graph.

22.  $y = \sqrt{x} + 3$

a.

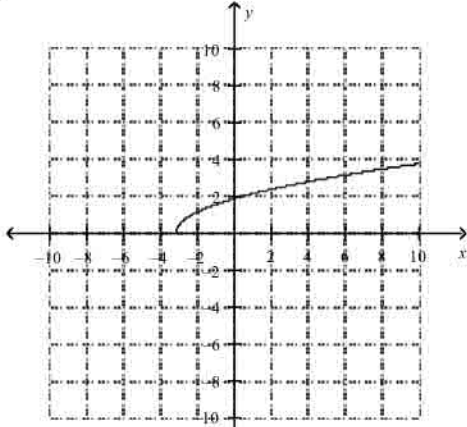

c.

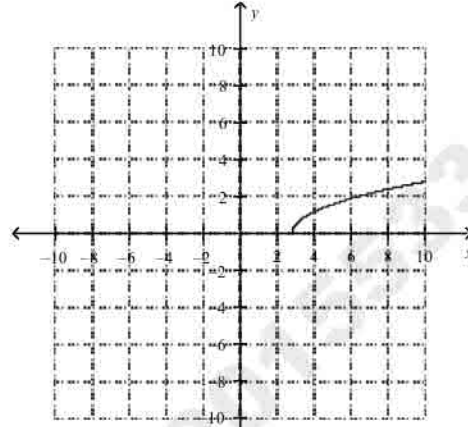

b.

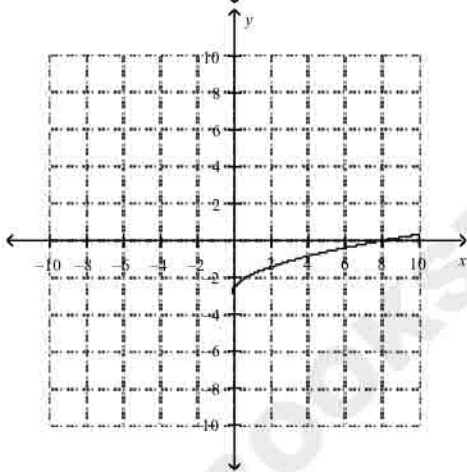

d.

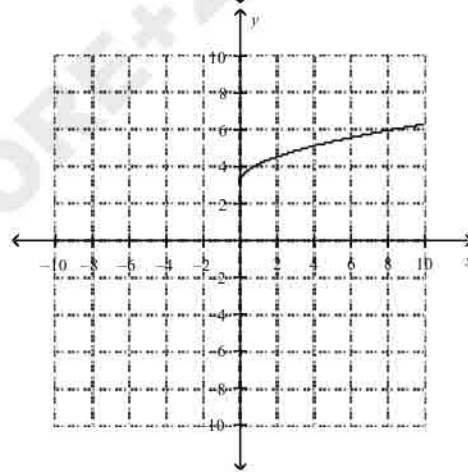

23.  $y = \sqrt{x} - 3$

a.

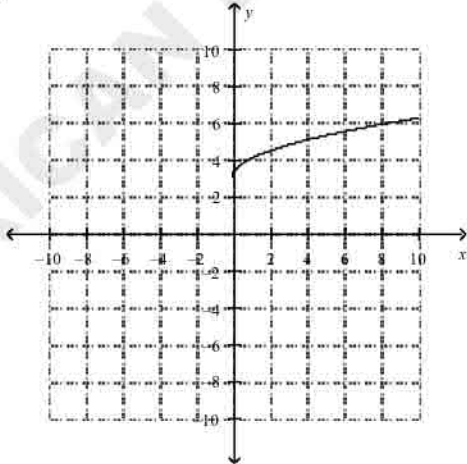

c.

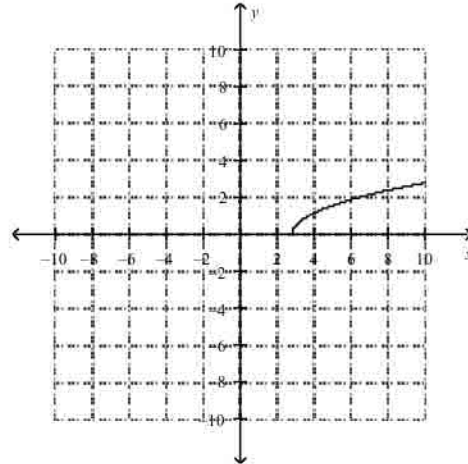

b.

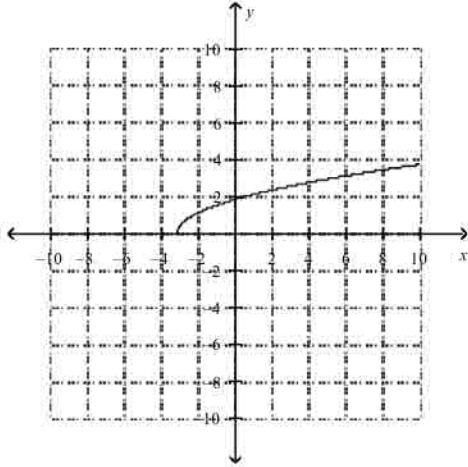

d.

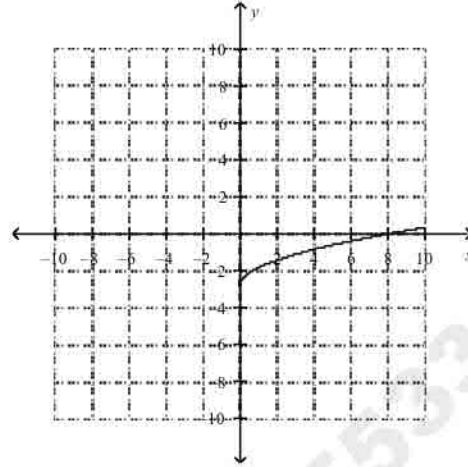

24.  $y = \sqrt{x+4}$

a.

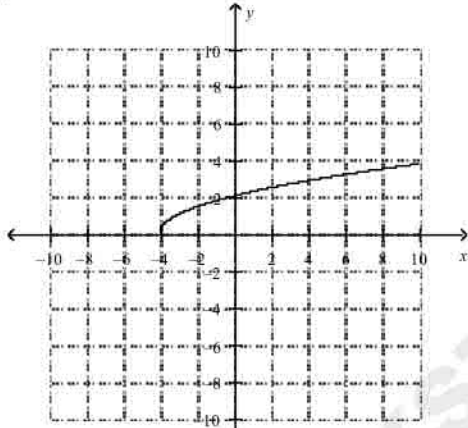

c.

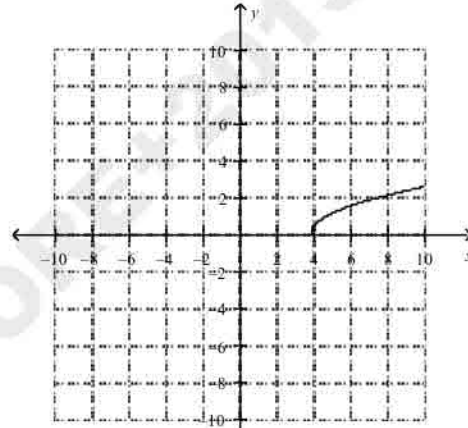

b.

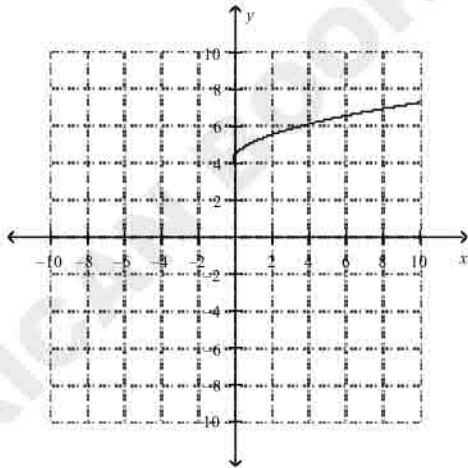

d.

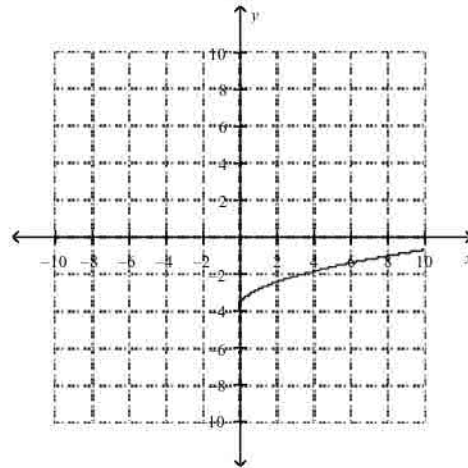

25.  $y = \sqrt{x-2}$

AMERICAN PSYCHOTON 1553389184

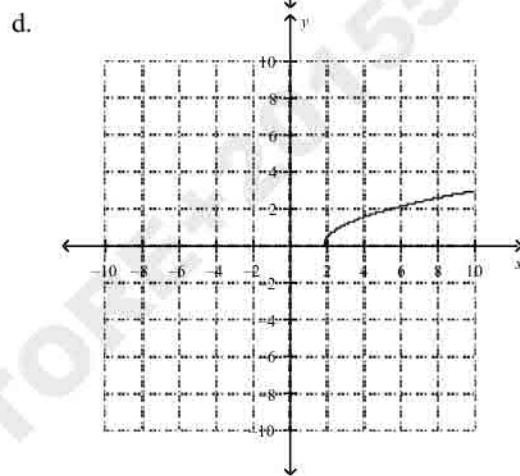
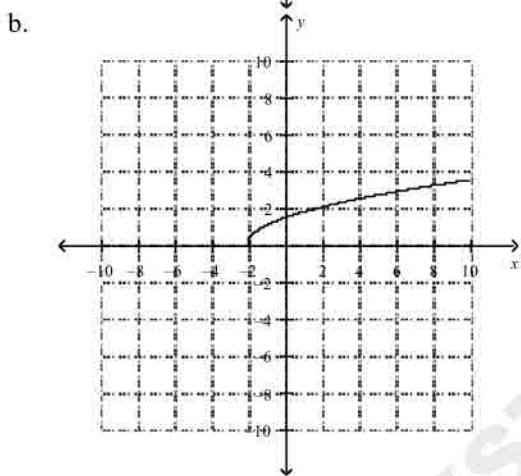
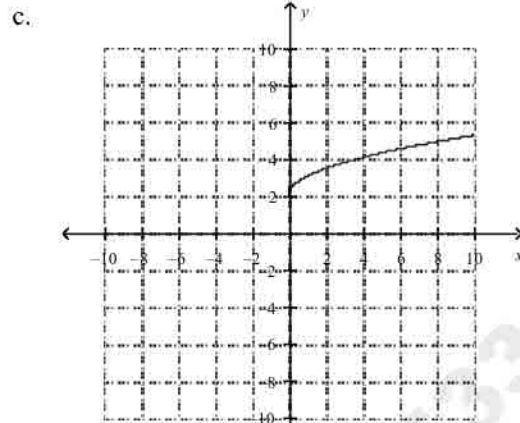
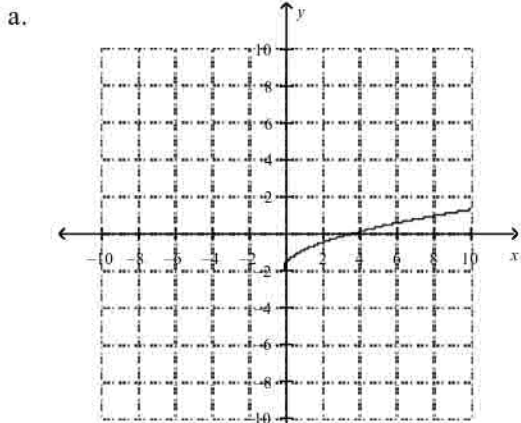

26. What is  $\sin A$  for the triangle shown?

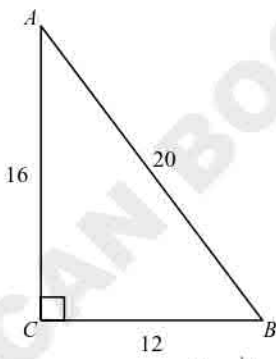

a.  $\frac{3}{4}$

b.  $\frac{3}{5}$

c.  $\frac{5}{3}$

d.  $\frac{4}{5}$

27. What is  $\cos A$  for the triangle shown?

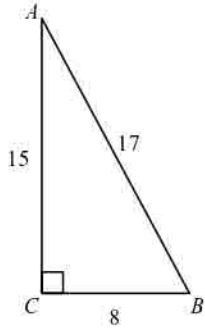

- a.  $\frac{8}{17}$       b.  $\frac{15}{17}$       c.  $\frac{8}{15}$       d.  $\frac{17}{8}$

28. What is  $\tan A$  for the triangle shown?

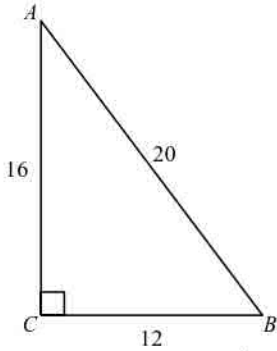

- a.  $\frac{4}{5}$       b.  $\frac{3}{4}$       c.  $\frac{5}{3}$       d.  $\frac{3}{5}$

Find the value of  $x$  to the nearest tenth.

29.

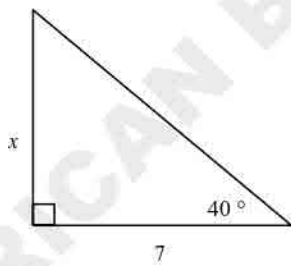

- a. 5.4      b. 5.9      c. -7.8      d. 4.5

30.

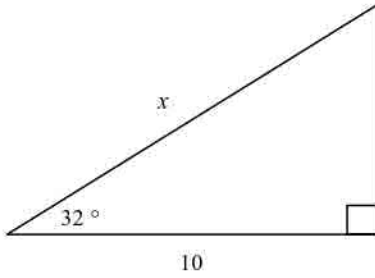

- a. 11.8                      b. 6.2                      c. 16                      d. 12

31. What is the measure of angle  $A$  in the triangle below?

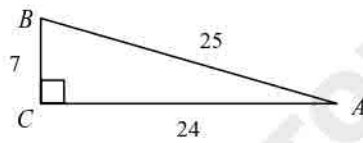

- a.  $73.7^\circ$                       b.  $16.3^\circ$                       c.  $25.2^\circ$                       d.  $90^\circ$

32. What is the measure of angle  $B$  in the triangle below?

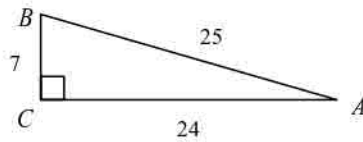

- a.  $73.7^\circ$                       b.  $90^\circ$                       c.  $25.2^\circ$                       d.  $16.3^\circ$

**Simplify the rational expression. State any excluded values.**

33.  $\frac{3x - 6}{x - 2}$
- a.  $\frac{3}{-2}$
- b. 6; where  $x \neq 3$
- c. 3; where  $x \neq 2$
- d.  $x$
34.  $\frac{2x - 4}{2x + 8}$
- a.  $\frac{x - 2}{x + 4}$ ; where  $x \neq -4$
- b.  $2\left(\frac{x + 2}{x - 4}\right)$ ; where  $x \neq 4$
- c.  $\frac{x + 4}{x - 2}$ ; where  $x \neq 2$
- d.  $\frac{x - 2}{2x + 8}$ ; where  $x \neq -4$
35.  $\frac{-14x^3}{x^3 - 3x^4}$
- a.  $\frac{-14x}{1 - 3x}$ ; where  $x \neq \frac{1}{3}$
- b.  $\frac{-14}{3x - 1}$ ; where  $x \neq \frac{1}{3}, 0$
- c.  $\frac{1 - 3x}{-14x}$ ; where  $x \neq 0$
- d.  $\frac{-14}{1 - 3x}$ ; where  $x \neq \frac{1}{3}, 0$
36.  $\frac{x - 2}{x^2 + 3x - 10}$
- a.  $x^2$
- b.  $x + 5$ ; where  $x \neq -5$
- c.  $\frac{1}{x^2}$ ; where  $x \neq -2$
- d.  $\frac{1}{x + 5}$ ; where  $x \neq -5, 2$
37.  $\frac{x^2 - 12x + 35}{x^2 - 3x - 10}$
- a.  $\frac{x - 5}{x - 2}$ ; where  $x \neq 2$
- b.  $\frac{x + 7}{x - 2}$ ; where  $x \neq 2$
- c.  $\frac{x - 7}{x + 2}$ ; where  $x \neq -2, 5$
- d.  $\frac{x - 7}{x - 5}$  where  $x \neq 5$
38.  $\frac{x^2 - 3x - 10}{-2 - x}$
- a.  $-x + 2$ ; where  $x \neq -5$
- b.  $x + 2$ ; where  $x \neq 5$
- c.  $-x + 5$ ; where  $x \neq -2$
- d.  $x + 5$ ; where  $x \neq 2$
39. Suppose that a sphere with radius  $5a$  has the same volume as a cone of radius  $3a$ . What is the height of the cone? Give your answer in terms of  $a$ . Use the formulas  $V = \frac{4}{3}\pi r^3$  and  $V = \frac{1}{3}\pi r^2 h$  for the volumes of a sphere and cone respectively.
- a.  $\frac{9}{500}a$
- b.  $\frac{500}{9}a^2$
- c.  $\frac{9}{500}a^2$
- d.  $\frac{500}{9}a$
40. Suppose that a sphere with radius  $5a$  has the same volume as a cylinder of radius  $2a$ . What is the height of the cylinder? Give your answer in terms of  $a$ . Use the formulas  $V = \frac{4}{3}\pi r^3$  and  $V = \pi r^2 h$  for the volumes of a sphere and cylinder respectively.

a.  $\sqrt[3]{125a^2}$

b.  $\sqrt[3]{125^a}$

c.  $\sqrt[3]{125} a$

d.  $\sqrt[3]{125} a^2$

**Multiply.**

41.  $\frac{y^2 - 16}{2y} \cdot \frac{5y}{y - 4}$

a.  $\frac{5(y + 4)}{2}$

b.  $\frac{5(y - 4)}{2}$

c.  $\frac{y + 4}{2}$

d.  $\frac{(y - 4)}{2}$

42.  $\frac{k + 3}{4k - 2} \cdot (12k^2 - 3)$

a.  $\frac{3(k + 3)}{2}$

b.  $\frac{3(k + 3)(2k - 1)}{2}$

c.  $\frac{3(k + 3)(2k + 1)}{2}$

d.  $3(k + 3)(2k + 1)$

**Divide.**

43.  $\frac{s^2 + 5s}{s^2 + 9s + 20} \div \frac{s - 3}{s + 4}$

a.  $\frac{s + 5}{s - 3}$

b.  $\frac{s - 3}{s}$

c.  $\frac{s}{s - 3}$

d.  $\frac{s + 5}{s^2 - 3s}$

44.  $\frac{x^2 + 2x + 1}{x - 2} \div \frac{x^2 - 1}{x^2 - 4}$

a.  $\frac{(x + 1)(x + 2)}{x - 1}$

b.  $\frac{(x - 1)(x - 2)}{x + 1}$

c.  $\frac{(x - 1)(x + 2)}{x + 1}$

d.  $\frac{(x + 1)(x - 2)}{x - 1}$

45.  $(14m^9 - 4m^8 + 8m^6) \div 2m^3$

a.  $7m^6 - 4m^8 + 8m^3$

b.  $7m^9 - 2m^8 + 4m^6$

c.  $7m^6 - 2m^5 + 4m^3$

d.  $7m^6 - 2m^5 + 8m^6$

46.  $(x^2 - 9x + 25) \div (x - 5)$

a.  $x - 9 - \frac{25}{x - 5}$

b.  $x - 4 - \frac{5}{x - 5}$

c.  $x - 4 + \frac{5}{x - 5}$

d.  $x - 9 - 5$

47.  $(x^3 - 11x - 6) \div (x + 3)$

a.  $-x^2 + 3x - 2$

b.  $x^2 - 3x - 2$

c.  $-x^2 - 3x + 2$

d.  $x^2 + 3x + 2$

48. The width  $w$  of a rectangular swimming pool is  $2x + 2$ . The area  $A$  of the pool is  $12x^3 - 26x - 14$ . What is an expression for the length of the pool?
- a.  $6x^2 - 6x + 7$                       c.  $6x^2 + 6x - 7$   
 b.  $6x^2 - 6x - 7$                       d.  $6x^2 + 6x + 7$

**Add or subtract.**

49.  $\frac{8}{x+3} - \frac{3}{x-2}$
- a.  $\frac{5x}{(x+3)(x-2)}$                       c.  $\frac{5x+25}{(x+3)(x-2)}$   
 b.  $\frac{5x-25}{(x+3)(x-2)}$                       d.  $\frac{-5x-25}{(x+3)(x-2)}$

50.  $\frac{5}{x-4} + \frac{3}{x+4}$
- a.  $\frac{8x-8}{(x-4)(x+4)}$                       c.  $\frac{8x}{(x-4)(x+4)}$   
 b.  $\frac{-8x+8}{(x-4)(x+4)}$                       d.  $\frac{8x+8}{(x-4)(x+4)}$

51.  $\frac{5}{x-1} - \frac{-1}{x+4}$
- a.  $\frac{6}{x-5}$                                       c.  $\frac{6x+19}{(x-1)(x+4)}$   
 b.  $\frac{19}{(x-1)(x+4)}$                       d.  $\frac{6}{(x-1)(x+4)}$

52. What is the graph of  $y = \frac{3}{x}$ ?

a.

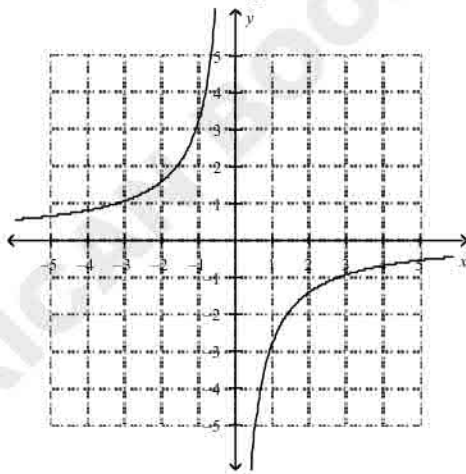

c.

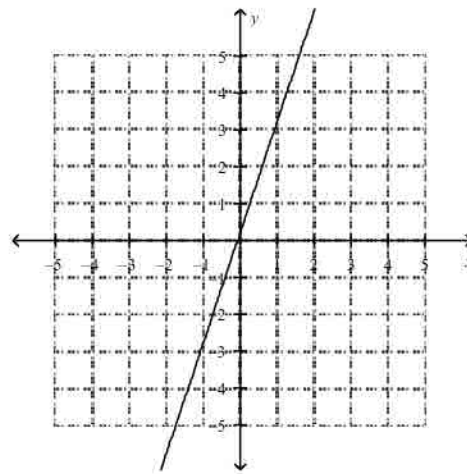

b.

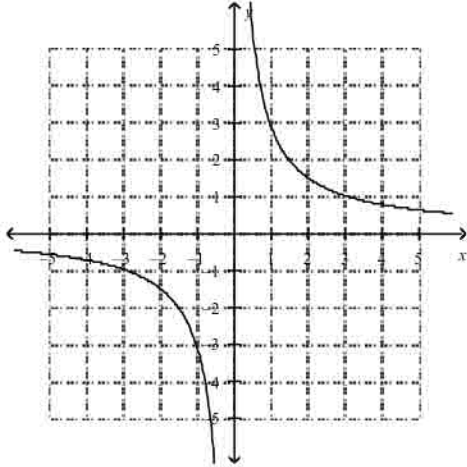

d.

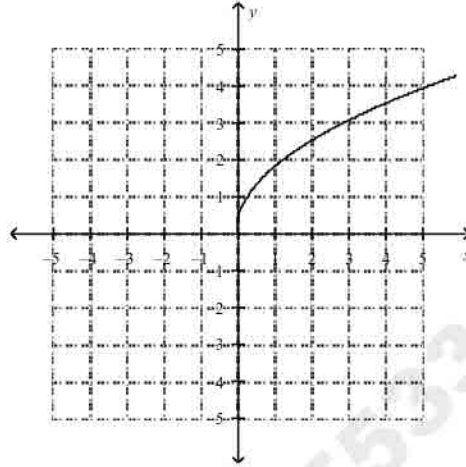

53. What is the graph of  $y = -\frac{2}{x}$ ?

a.

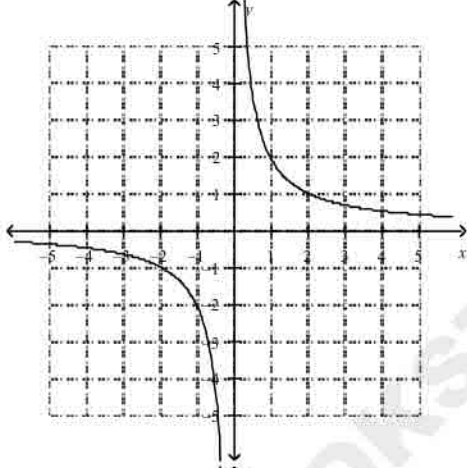

c.

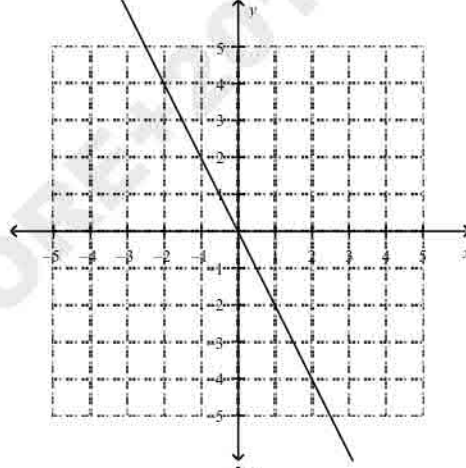

b.

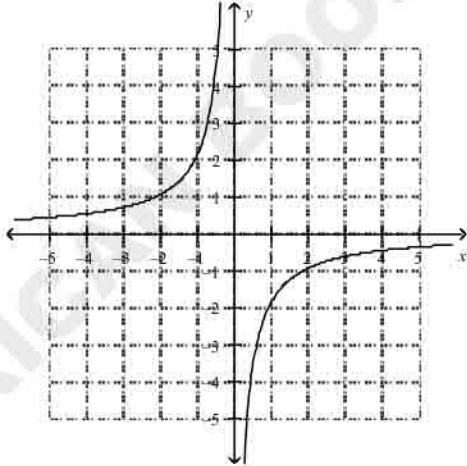

d.

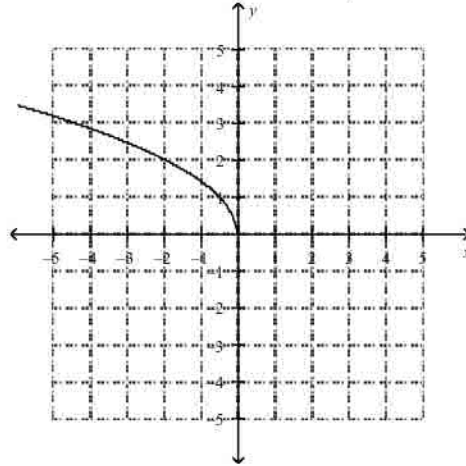

Do the data in the table represent a direct variation or an inverse variation? Write an equation to model the data in the table.

54.

$x$	5	10	15	20
-----	---	----	----	----

y	50	100	150	200
---	----	-----	-----	-----

- a. inverse variation;  $xy = 10$   
 b. direct variation;  $y = 10x$

- c. direct variation;  $y = \frac{1}{10}x$   
 d. inverse variation;  $xy = \frac{1}{10}$

55.

x	2	4	8	12
y	4	2	1	$\frac{2}{3}$

- a. direct variation;  $y = \frac{8}{x}$   
 b. inverse variation;  $\frac{y}{x} = 8$

- c. direct variation;  $y = 8x$   
 d. inverse variation;  $xy = 8$

Graph the function and identify the vertical asymptote.

56.  $y = \frac{1}{x-1} - 3$

a.

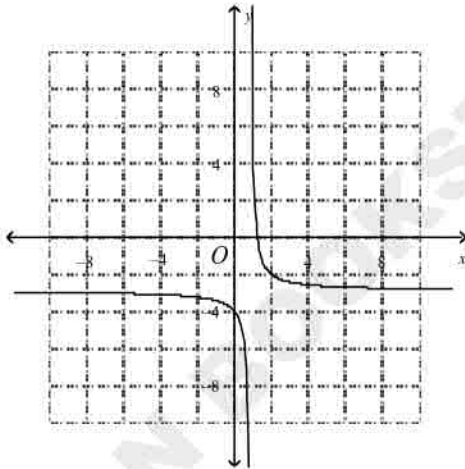

$x = 1$

c.

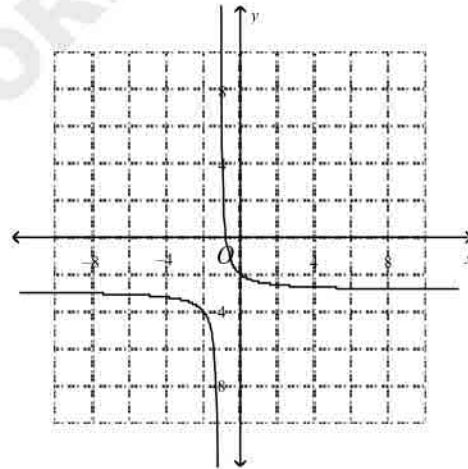

$x = -1$

y

b.

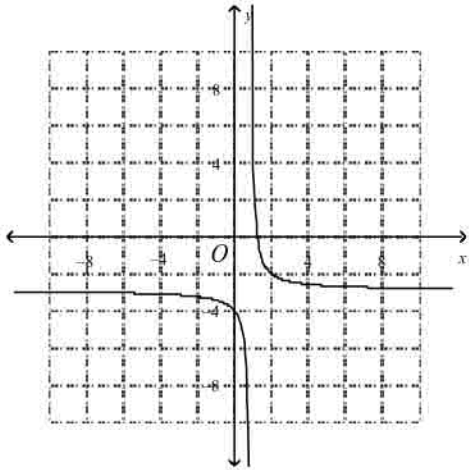

d.

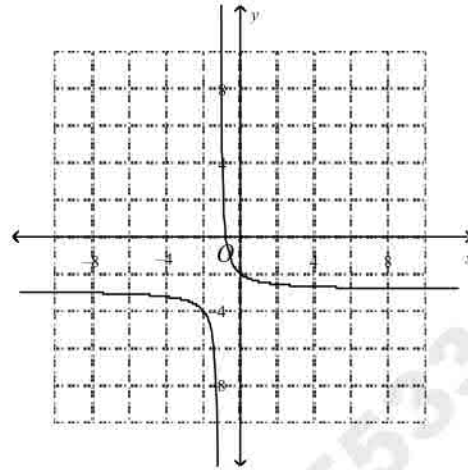

$y = 1$

$y$

$x = -1$

57.  $y = \frac{1}{x+1} - 2$

a.

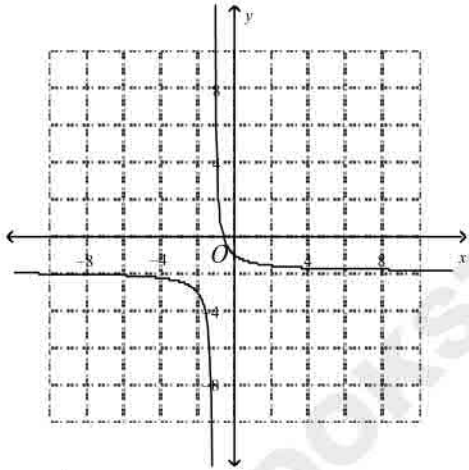

c.

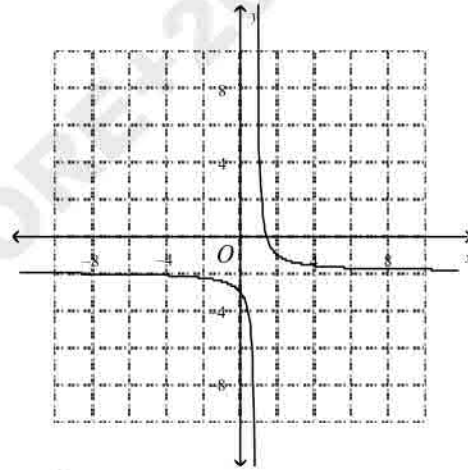

$x = -1$

$x = 1$

b.

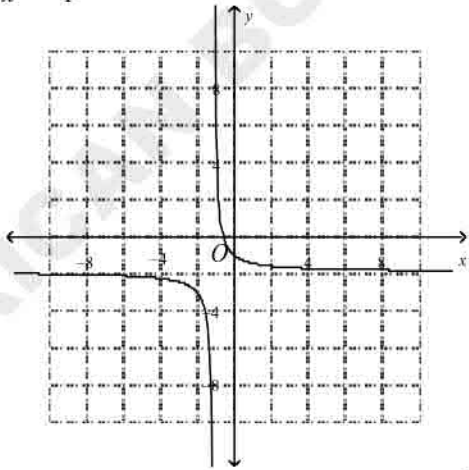

d.

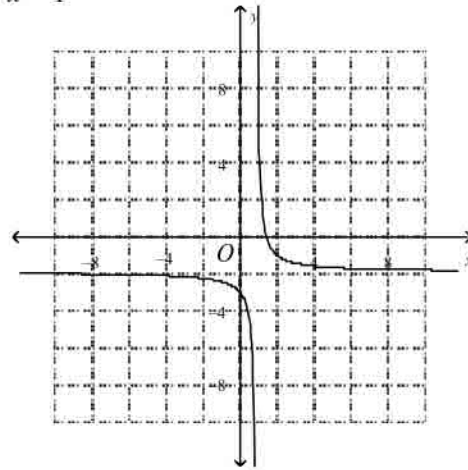

$y = -1$

$y$

$y = 1$

$y$

Identify the asymptotes of the graph.

58.  $y = \frac{1}{x+1} - 2$

a.

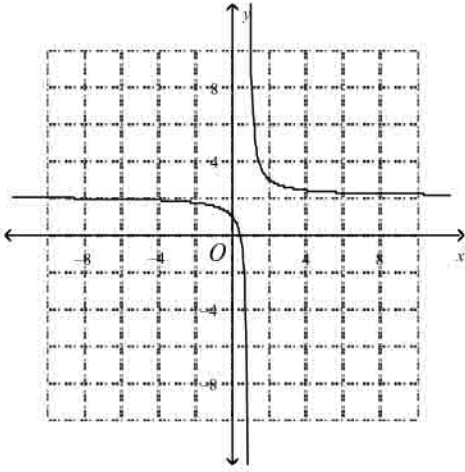

c.

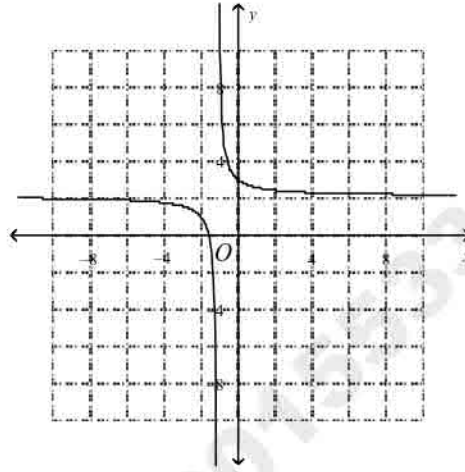

$x = 1, y = 2$

b.

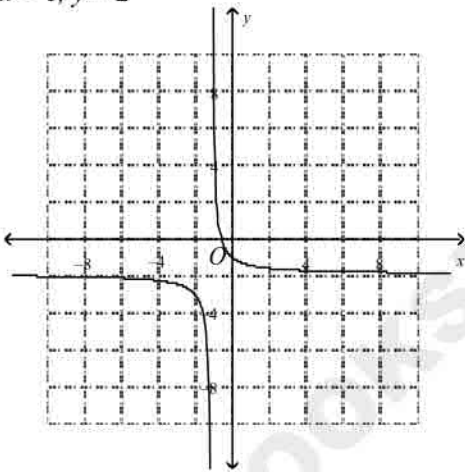

$x = -1, y = 2$

d.

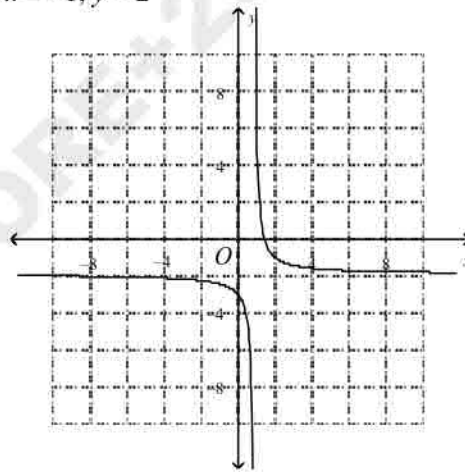

$x = -1, y = -2$

$x = 1, y = 2$

59.  $y = \frac{1}{x-2} - 4$

a.

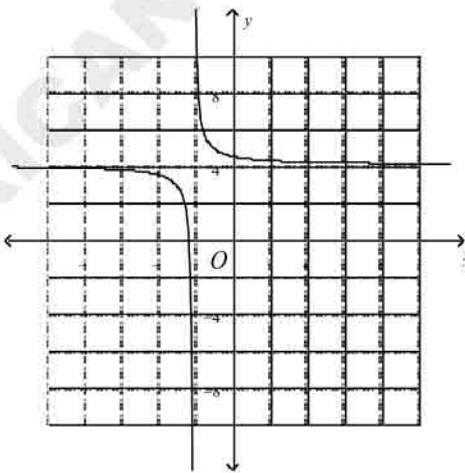

c.

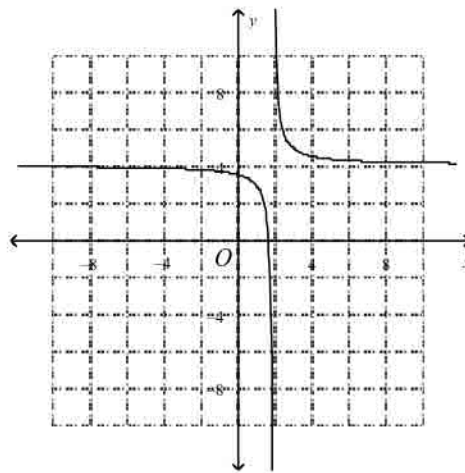

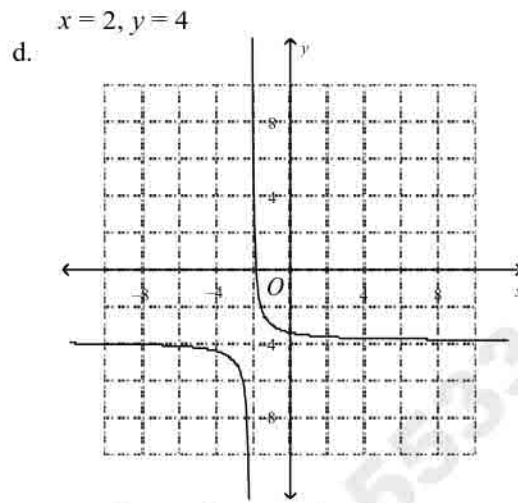
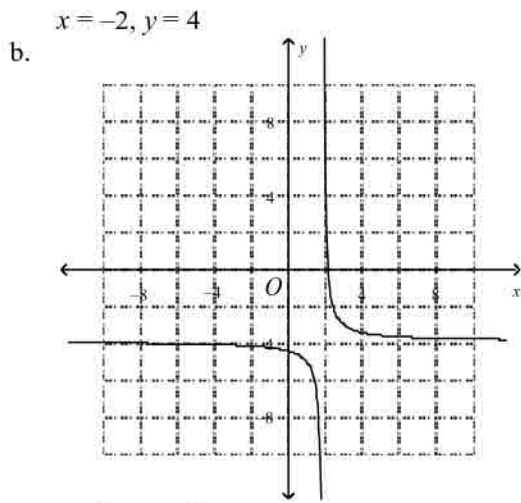

$x = 2, y = -4$

$x = -2, y = -4$

60. The number of hours a group of contestants spent preparing for a quiz show are listed below. What is a frequency table that represents the data?

60 25 86 56 45 48 90 75 30 67 90 36 80 15 32 65 61

a.

Hours	Frequency
0 - 9	0
10 - 19	1
20 - 29	1
30 - 39	3
40 - 49	2
50 - 59	1
60 - 69	4
70 - 79	1
80 - 89	2
90 - 99	2

c.

Hours	Frequency
0 - 9	0
10 - 19	1
20 - 29	2
30 - 39	1
40 - 49	2
50 - 59	1
60 - 69	4
70 - 79	1
80 - 89	1
90 - 99	1

b.

Hours	Frequency
0 – 9	4
10 – 19	1
20 – 29	1
30 – 39	2
40 – 49	3
50 – 59	4
60 – 69	1
70 – 79	1
80 – 89	1
90 – 99	1

d.

Hours	Frequency
0 – 9	1
10 – 19	2
20 – 29	1
30 – 39	2
40 – 49	2
50 – 59	3
60 – 69	3
70 – 79	1
80 – 89	0
90 – 99	2

61. The data below shows the average number of text messages a group of students send per day. What is a histogram that represents the data?

20 5 8 22 10 1 7 15 16 12 15 6 13 8

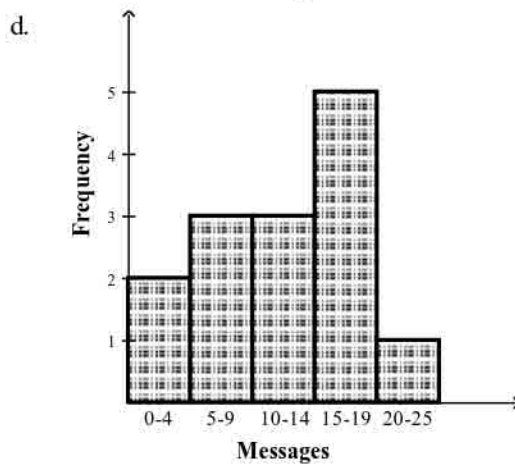
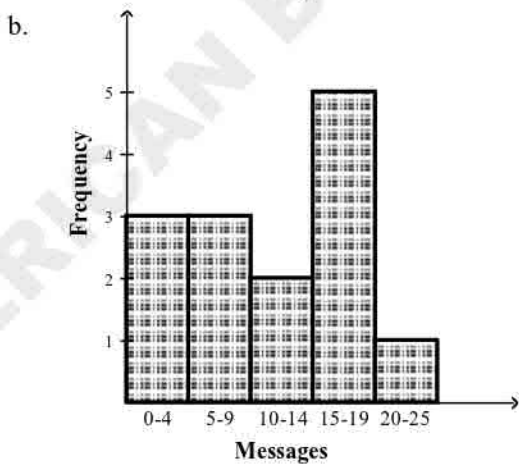
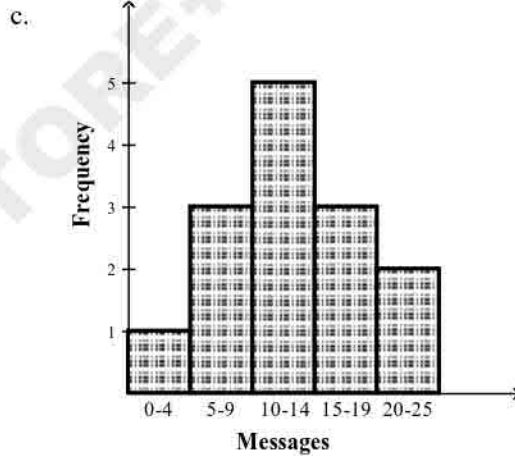
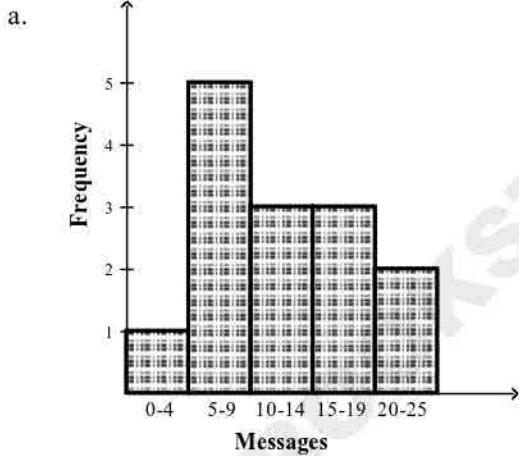

62. The data below show the number of games won by a football team in each of the last 15 seasons. What is a histogram that represents the data?

3 4 8 12 7 2 1 15 16 6 10 13 4 1 5

a.

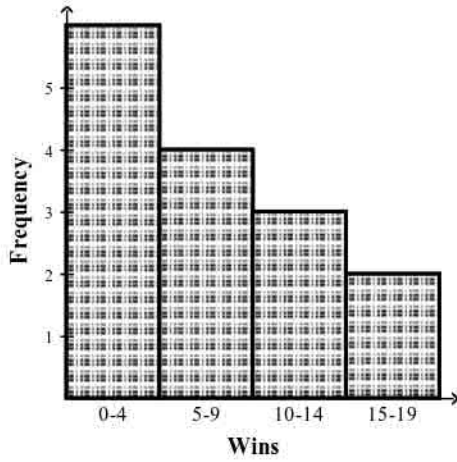

c.

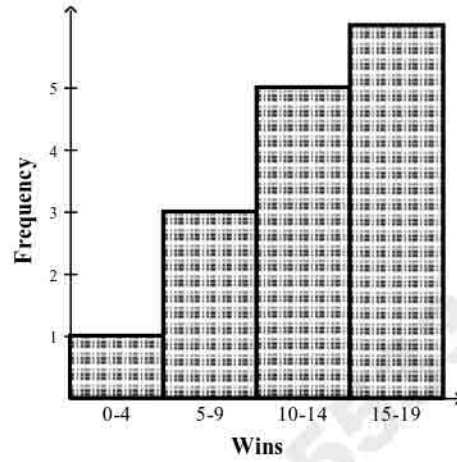

b.

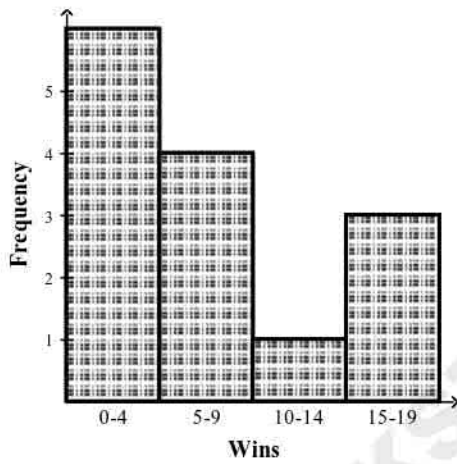

d.

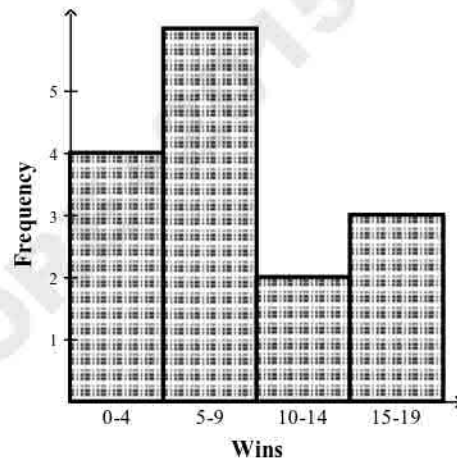

63. The data below shows the number of kilowatt hours of electricity used by the tenants of a small apartment building in a given month. What is a cumulative frequency table that represents the data?

80 85 86 90 96 75 66 70  
99 65 70 99 70 73 64 92  
72 81 88 91 93 69 77 82

a.

Kilowatt Hours	Frequency	Cumulative Frequency
60 – 69	7	7
70 – 79	4	11
80 – 89	7	18
90 – 99	6	24

b.

Kilowatt Hours	Frequency	Cumulative Frequency
60 – 69	4	4
70 – 79	7	11
80 – 89	6	17
90 – 99	7	24

c.

Kilowatt Hours	Frequency	Cumulative Frequency
60 – 69	7	24
70 – 79	4	24
80 – 89	5	24
90 – 99	6	24

d.

Kilowatt Hours	Frequency	Cumulative Frequency
60 – 69	4	4
70 – 79	6	10
80 – 89	7	17
90 – 99	7	24

Find the mean, median, and mode of the data set. Round to the nearest tenth.

64. 15, 1, 4, 4, 8, 7, 15, 4, 15, 4, 5  
 a. mean = 6.8, median = 5, mode = 4  
 b. mean = 7.5, median = 5, mode = 4  
 c. mean = 7.5, median = 8, mode = 4  
 d. mean = 6.8, median = 5, mode = 8
65. Find  $x$  if the average of 20, 20, 19, 13, and  $x$  is 16.  
 a. 8  
 b. 9  
 c. 10  
 d. 6
66. The table shows the number of hours that a group of students spent studying for the SAT during their first week of preparation. The students each add 3 hours to their study times in the second week. What are the mean, median, mode, and range of times for the second week?

Student	Hours
Bob	20
James	10
Karen	10
Rosario	11
Antoine	13
Julio	17
Maria	15

- |  |  |
|--|--|
| a. mean = 13<br>median = 16<br>mode = 16.7<br>range = 10   | c. mean = 16.7<br>median = 16<br>mode = 13<br>range = 10   |
| b. mean = 16<br>median = 16.7<br>mode = 13<br>range = -0.7 | d. mean = 16.7<br>median = 16<br>mode = 13<br>range = -0.7 |

What are the minimum, first quartile, median, third quartile, and maximum of the data set?

67. 9, 20, 4, 18, 4, 18, 20, 9
- minimum 4; first quartile 10; median 16.25; third quartile 19.5; maximum 20
  - minimum 4; first quartile 6.5; median 13.5; third quartile 19.5; maximum 20
  - minimum 4; first quartile 6.5; median 13.5; third quartile 19; maximum 20
  - minimum 4; first quartile 5.25; median 16.25; third quartile 19; maximum 20

Make a box-and-whisker plot of the data.

68. 21, 27, 22, 22, 25, 14, 16, 10
- - 
  - 
  -

69. The two box-and-whisker plots below show the times in seconds for two teams in a 100 m dash. What do the interquartile ranges tell you about the two teams?

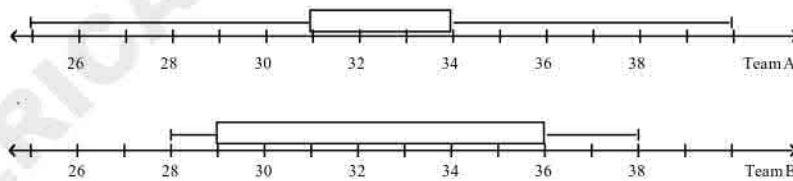

- Team A has more consistent times
  - Team B has more consistent times
  - Overall team A is faster than team B
  - Overall team B is faster than team A
70. You roll a standard number cube. Find  $P(\text{number greater than 5})$

ALL QUESTIONS HAVE BEEN COLLECTED FROM PEARSON

- a.  $\frac{2}{5}$                       b.  $\frac{5}{6}$                       c.  $\frac{1}{3}$                       d.  $\frac{1}{6}$

\_\_\_\_ 71. You have the numbers 1–25 written on slips of paper. If you choose one slip at random, what is the probability that you will select a number which is divisible by 4?

- a.  $\frac{1}{5}$                       b.  $\frac{6}{25}$                       c.  $\frac{4}{25}$                       d.  $\frac{2}{3}$

\_\_\_\_ 72. You have the numbers 1–24 written on slips of paper. If you choose one slip at random, what is the probability that you will NOT select a number which is divisible by 3?

- a.  $\frac{3}{8}$                       b.  $\frac{1}{3}$                       c.  $\frac{5}{8}$                       d.  $\frac{2}{3}$

AMERICAN BOOKSTORE+201553389184

**Answer Section**

**MULTIPLE CHOICE**

1. ANS: B
2. ANS: B
3. ANS: A
4. ANS: A
5. ANS: C
6. ANS: C
7. ANS: C
8. ANS: B
9. ANS: B
10. ANS: C
11. ANS: B
12. ANS: B
13. ANS: A
14. ANS: D
15. ANS: C
16. ANS: B
17. ANS: B
18. ANS: A
19. ANS: C
20. ANS: C
21. ANS: D
22. ANS: D
23. ANS: D
24. ANS: A
25. ANS: D
26. ANS: B
27. ANS: B
28. ANS: B
29. ANS: B
30. ANS: A
31. ANS: B
32. ANS: A
33. ANS: C
34. ANS: A
35. ANS: D
36. ANS: D
37. ANS: C
38. ANS: C
39. ANS: D
40. ANS: C

ALL QUESTIONS HAVE BEEN COLLECTED FROM PEARSON

- 41. ANS: A
- 42. ANS: C
- 43. ANS: C
- 44. ANS: A
- 45. ANS: C
- 46. ANS: C
- 47. ANS: B
- 48. ANS: B
- 49. ANS: B
- 50. ANS: D
- 51. ANS: C
- 52. ANS: B
- 53. ANS: B
- 54. ANS: B
- 55. ANS: D
- 56. ANS: A
- 57. ANS: A
- 58. ANS: B
- 59. ANS: B
- 60. ANS: A
- 61. ANS: A
- 62. ANS: A
- 63. ANS: B
- 64. ANS: B
- 65. ANS: A
- 66. ANS: C
- 67. ANS: C
- 68. ANS: C
- 69. ANS: A
- 70. ANS: D
- 71. ANS: B
- 72. ANS: D

AMERICAN BOOKSTORE+201553389184



**Multiple Choice**

Identify the choice that best completes the statement or answers the question.

**What is the simplified form of each expression?**

- \_\_\_ 1.  $(-4.2)^0$   
 a.  $-1$                       b.  $1$                       c.  $-4.2$                       d.  $0$
- \_\_\_ 2.  $-(4)^{-2}$   
 a.  $-\frac{1}{-2^4}$                       b.  $4^2$                       c.  $\frac{1}{4^2}$                       d.  $-\frac{1}{4^2}$
- \_\_\_ 3.  $(-3)^{-2}$   
 a.  $-\frac{1}{9}$                       b.  $9$                       c.  $\frac{1}{9}$                       d.  $6$
- \_\_\_ 4.  $\frac{1}{a^{-5}}$   
 a.  $a^5$                       b.  $-a^5$                       c.  $5a$                       d.  $-\frac{5}{a}$

**What is each expression written using each base only once?**

- \_\_\_ 5.  $(-5)^{-5} \cdot (-5)^6$   
 a.  $-5$                       b.  $5^{11}$                       c.  $1$                       d.  $11$
- \_\_\_ 6.  $7^{10} \cdot 7^{-4} \cdot 7^7$   
 a.  $7^{13}$                       b.  $21^{13}$                       c.  $7^{-280}$                       d.  $343^{13}$

**What is the simplified form of each expression?**

- \_\_\_ 7.  $7x^{-8} \cdot 6x^3$   
 a.  $\frac{42}{x^5}$                       b.  $\frac{1}{42x^5}$                       c.  $42x^{11}$                       d.  $13x^{-5}$

**What is the simplified form of the expression?**

- \_\_\_ 8.  $(x^{-2})^4$   
 a.  $\frac{1}{x^8}$                       b.  $\frac{1}{x^{16}}$                       c.  $x^8$                       d.  $\frac{x}{8}$

**What is the simplified form of each expression?**

- \_\_\_ 9.  $\frac{t^{11}}{t^2}$   
 a.  $t^{13}$                       b.  $t^{22}$                       c.  $\frac{1}{t^9}$                       d.  $t^9$

10.  $\frac{y^{-2}}{y^5}$

a.  $\frac{1}{y^3}$                       b.  $y^7$                       c.  $\frac{1}{y^7}$                       d.  $y^3$

11.  $\frac{c^9 d^{-7}}{c^{14} d^{-10}}$

a.  $\frac{d^2}{d^4}$                       b.  $c^5 d^3$                       c.  $\frac{d^3}{c^5}$                       d.  $c^2 d^4$

What is the simplified form of the expression?

12.  $\left(\frac{4k^4}{7c^3}\right)^3$

a.  $28k^{12}c^9$                       b.  $\frac{64k^{12}}{343c^9}$                       c.  $\frac{12k^{12}}{21c^9}$                       d.  $\frac{64k^{12}}{7c}$

13.  $\left(\frac{m^{-1}m^5}{m^{-2}}\right)^{-3}$

a.  $\frac{3m^4}{m^{-2}}$                       b.  $\frac{1}{m^{18}}$                       c.  $m^{18}$                       d.  $-m^{216}$

14.  $\left(\frac{3x^5}{8j^4}\right)^{-3}$

a.  $24x^{15}j^{12}$                       b.  $\frac{512j^{12}}{27x^{15}}$                       c.  $\frac{-24x^{15}}{9j^{12}}$                       d.  $\frac{512x^{15}}{8j}$

What is the graph of the function?

15.  $y = 3 \cdot 5^x$

a.

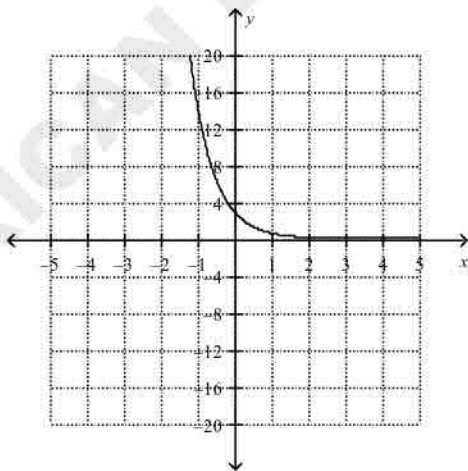

c.

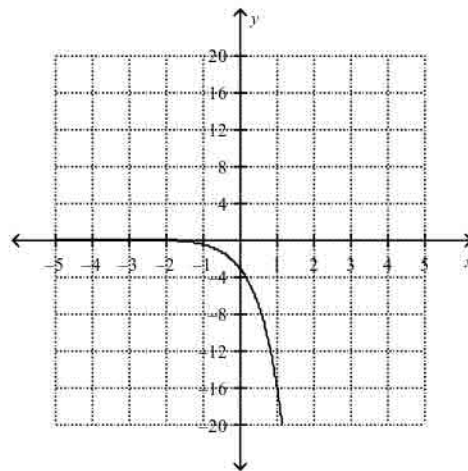

b.

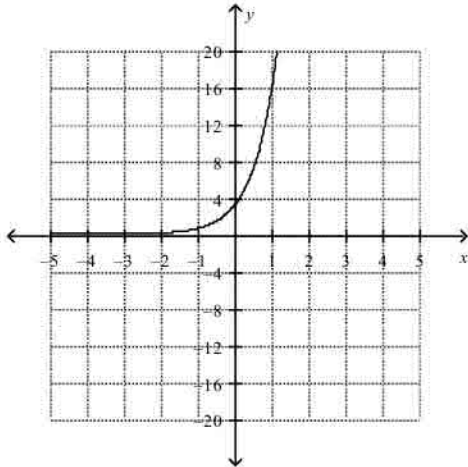

d.

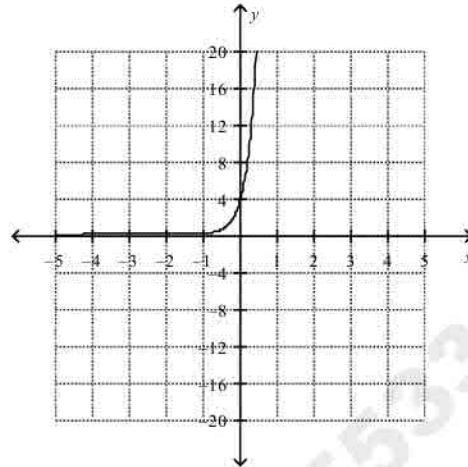

16.  $y = -4 \cdot 5^x$

a.

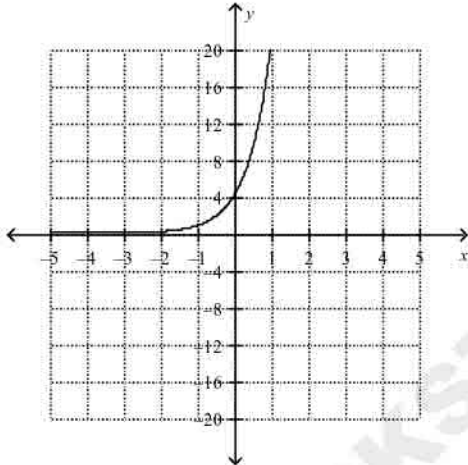

c.

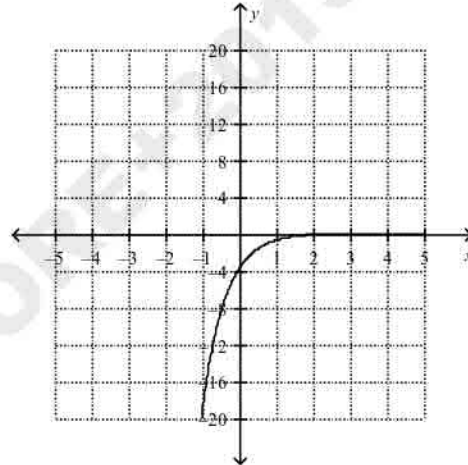

b.

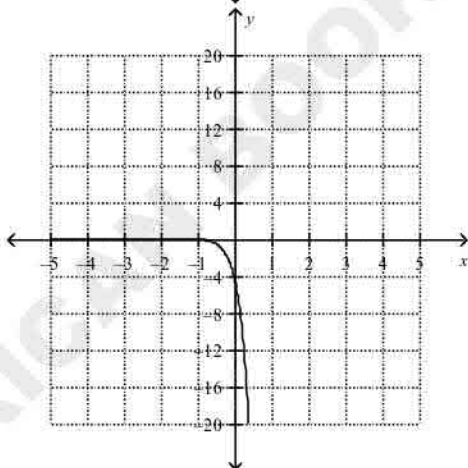

d.

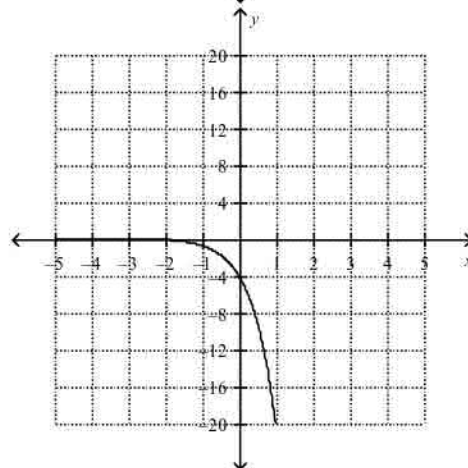

17. Suppose the population of a town is 8,600 and is growing 3% each year. Predict the population after 3 years.

- a. about 77,400 people
- b. about 9,397 people
- c. about 26574 people
- d. about 232,200 people

18. Suppose that the population of deer in a state is 1,500 and is growing 2% each year. Predict the population after 4 years.
- a. about 12,000 deer
  - b. about 1,624 deer
  - c. about 3,110 deer
  - d. about 24,000 deer

What are the coordinates of the vertex of the graph? Is it a maximum or minimum?

19.

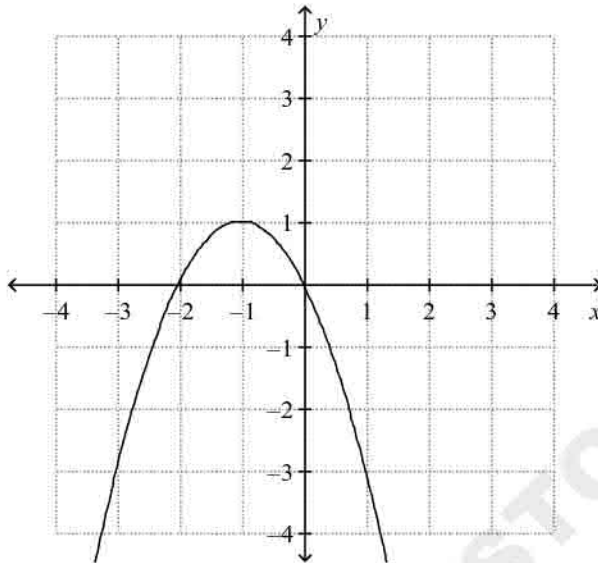

- a.  $(-1, 1)$ ; minimum
- b.  $(1, -1)$ ; maximum
- c.  $(1, -1)$ ; minimum
- d.  $(-1, 1)$ ; maximum

20.

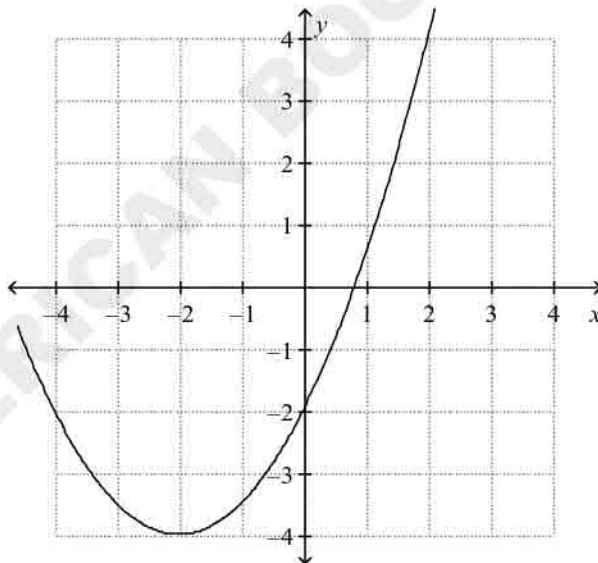

- a.  $(-4, -2)$ ; minimum
- c.  $(-2, -4)$ ; minimum

b.  $(-2, -4)$ ; maximum

d.  $(-4, -2)$ ; maximum

Order the group of quadratic functions from widest to narrowest graph.

21.  $y = 3x^2, y = x^2, y = 2x^2$   
 a.  $y = 3x^2, y = 2x^2, y = x^2$   
 b.  $y = 2x^2, y = x^2, y = 3x^2$   
 c.  $y = x^2, y = 2x^2, y = 3x^2$   
 d.  $y = x^2, y = 3x^2, y = 2x^2$
22.  $y = -4x^2, y = -3x^2, y = -5x^2$   
 a.  $y = -3x^2, y = -5x^2, y = -4x^2$   
 b.  $y = -5x^2, y = -4x^2, y = -3x^2$   
 c.  $y = -3x^2, y = -4x^2, y = -5x^2$   
 d.  $y = -4x^2, y = -3x^2, y = -5x^2$
23. How is the graph of  $y = 3x^2 + 3$  different from the graph of  $y = 3x^2$ ?  
 a. It is shifted 3 unit(s) up.  
 b. It is shifted 3 unit(s) down.  
 c. It is shifted 3 unit(s) left.  
 d. It is shifted 3 unit(s) right.
24. How is the graph of  $y = -4x^2 - 5$  different from the graph of  $y = -4x^2$ ?  
 a. It is shifted 5 unit(s) right.  
 b. It is shifted 5 unit(s) left.  
 c. It is shifted 5 unit(s) up.  
 d. It is shifted 5 unit(s) down.
25. If an object is dropped from a height of 144 feet, the function  $h(t) = -16t^2 + 144$  gives the height of the object after  $t$  seconds. When will the object hit the ground?  
 a. 9 s  
 b. 6 s  
 c. 1.5 s  
 d. 3 s

Graph the function. Identify the vertex and axis of symmetry.

26.  $f(x) = x^2 + 4x + 1$

a.

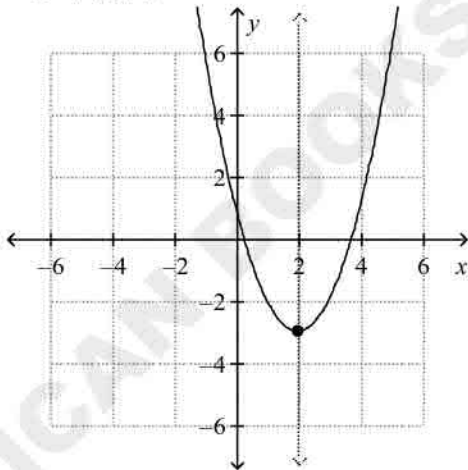

axis of symmetry:  $x = 2$   
 vertex:  $(2, -3)$

c.

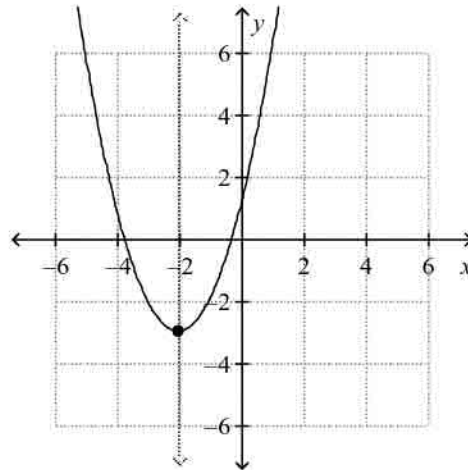

axis of symmetry:  $x = -2$   
 vertex:  $(-2, -3)$

b.

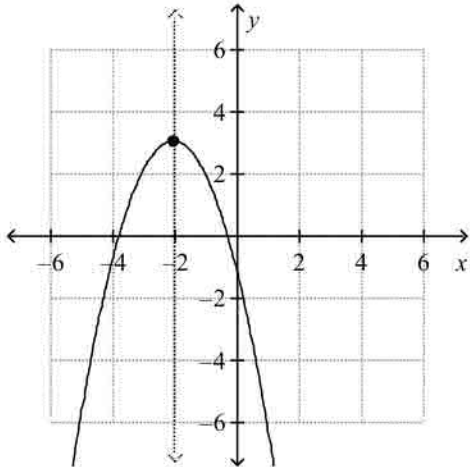

axis of symmetry:  $x = -2$   
vertex:  $(-2, 3)$

d.

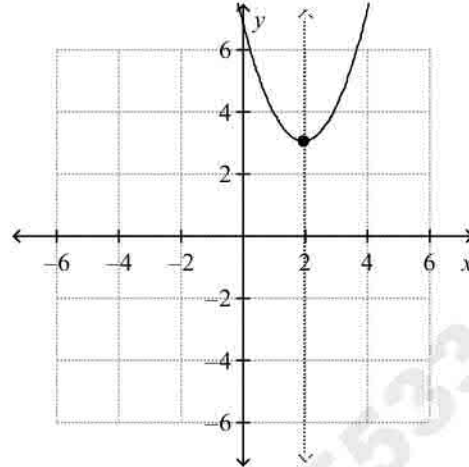

axis of symmetry:  $x = 2$   
vertex:  $(2, 3)$

27.  $f(x) = -2x^2 + 2x - 1$

a.

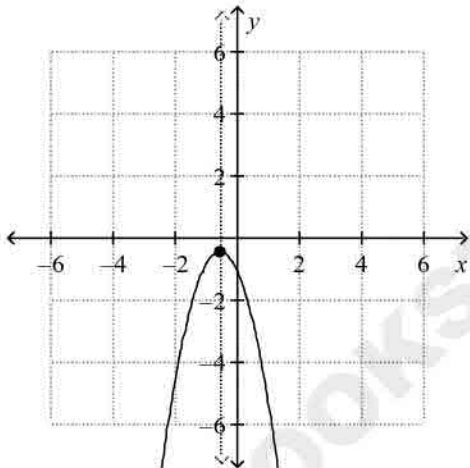

axis of symmetry:  $x = -0.5$   
vertex:  $(-0.5, -0.5)$

c.

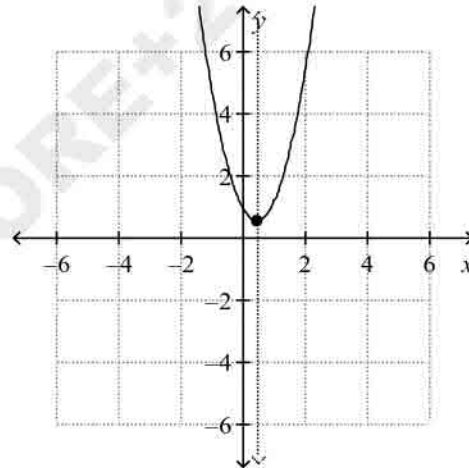

axis of symmetry:  $x = 0.5$   
vertex:  $(0.5, 0.5)$

b.

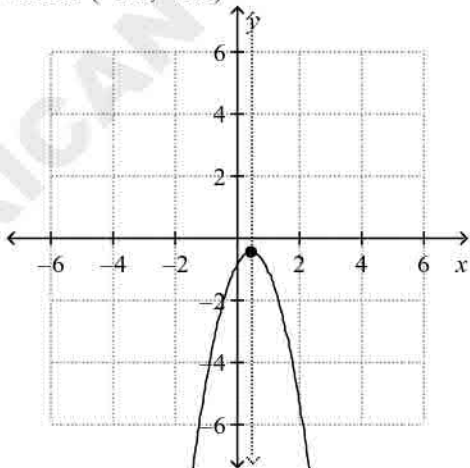

d.

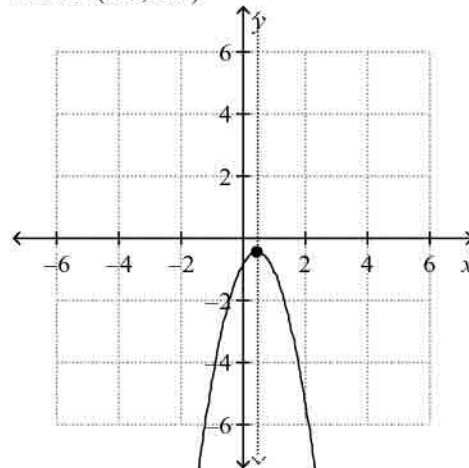

axis of symmetry:  $x = 0.5$   
vertex:  $(0.5, -0.5)$

axis of symmetry:  $x = 0.5$   
vertex:  $(0.5, 0.5)$

Solve the equation using square roots.

28.  $x^2 - 9 = 0$   
a.  $-3, 3$   
b.  $-9, 9$

- c.  $-\sqrt{3}, \sqrt{3}$   
d. no real number solutions

What are the solutions of the equation?

29.  $c^2 - 10c = 0$   
a.  $1, -\sqrt{10}$   
b.  $0, -10$

- c.  $0, \sqrt{10}$   
d.  $0, 10$

30. A rocket is launched from atop a 65-foot cliff with an initial velocity of 113 ft/s. The height of the rocket above the ground at time  $t$  is given by  $h = -16t^2 + 113t + 65$ . When will the rocket hit the ground after it is launched? Round to the nearest tenth of a second.  
a. 0.5 s  
b. 7.6 s

- c. 3.5 s  
d. 7.1 s

31. A campground consists of 8 square campsites arranged in a line along a beach. The distance from the edge of a campsite to the water at the end of the beach is 5 yd. The area of the campground, including the beach, is 1220 sq yd. What is the width of one campsite?

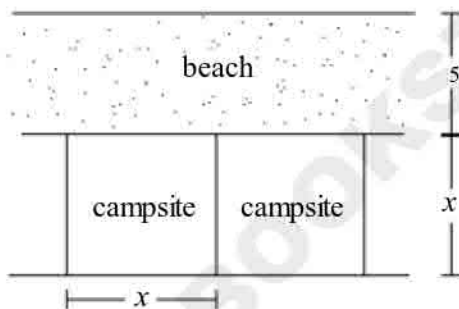

- a. 8.32 yd  
b. 10.1 yd

- c. 13.32 yd  
d. 12.6 yd

Simplify the rational expression. State any excluded values.

32.  $\frac{3x - 6}{x - 2}$   
a.  $-\frac{3}{2}$

- c. 3; where  $x \neq 2$

- b. 6; where  $x \neq 3$

- d.  $x$

33.  $\frac{2x}{-5x + x^2}$   
a.  $-\frac{2}{5}$

- c.  $\frac{2}{x - 5}$ ; where  $x \neq 5, 0$

b.  $\frac{2}{x}$ ; where  $x \neq 0$

d.  $-\frac{2}{5} + \frac{1}{x}$ ; where  $x \neq 0$

34.  $\frac{x-2}{x^2+3x-10}$

a.  $x^2$

c.  $\frac{1}{x^2}$ ; where  $x \neq -2$

b.  $x+5$ ; where  $x \neq -5$

d.  $\frac{1}{x+5}$ ; where  $x \neq -5, 2$

35. Suppose that a sphere with radius  $5a$  has the same volume as a cylinder of radius  $2a$ . What is the height of the cylinder? Give your answer in terms of  $a$ . Use the formulas  $V = \frac{4}{3}\pi r^3$  and  $V = \pi r^2 h$  for the volumes of a sphere and cylinder respectively.

a.  $\frac{3}{125}a^2$

b.  $\frac{3}{125}a$

c.  $\frac{125}{3}a$

d.  $\frac{125}{3}a^2$

**Multiply. State any excluded values.**

36.  $\frac{q+5}{-3} \cdot \frac{-3q}{q+2}$

a.  $\frac{-3q^2-15q}{-3}$ ; where  $q \neq 3$

c.  $\frac{q^2-15q}{-3q}$ ; where  $q \neq 0$

b.  $\frac{-3q-15q^2}{2q-6}$ ; where  $q \neq 3$

d.  $\frac{-3q^2-15q}{-3q-6}$ ; where  $q \neq -2$

**Multiply.**

37.  $\frac{x^2-8x+15}{3x} \cdot \frac{8x}{x-3}$

a.  $\frac{8(x-3)}{3}$

c.  $\frac{3(x-5)}{8}$

b.  $\frac{8(x-5)}{3}$

d.  $\frac{3(x-3)}{8}$

38.  $\frac{k+3}{4k-2} \cdot (12k^2-3)$

a.  $\frac{3(k+3)}{2}$

c.  $\frac{3(k+3)(2k+1)}{2}$

b.  $\frac{3(k+3)(2k-1)}{2}$

d.  $3(k+3)(2k+1)$

**Divide.**

39.  $(14m^9 - 4m^8 + 8m^6) \div 2m^3$

a.  $7m^6 - 4m^8 + 8m^3$

c.  $7m^6 - 2m^5 + 4m^3$

b.  $7m^9 - 2m^8 + 4m^6$

d.  $7m^6 - 2m^5 + 8m^6$

40.  $(25x^2 - 40x + 18) \div (5x - 3)$

a.  $5x - 8 - 6$

b.  $5x - 8 - \frac{18}{5x - 3}$

c.  $5x - 5 + \frac{3}{5x - 3}$

d.  $5x - 5 - \frac{3}{5x - 3}$

41.  $(x^3 - 11x - 6) \div (x + 3)$

a.  $-x^2 + 3x - 2$

b.  $x^2 - 3x - 2$

c.  $-x^2 - 3x + 2$

d.  $x^2 + 3x + 2$

**Divide.**

42.  $(-6x + x^2 + 12) \div (-2 + x)$

a.  $x - 6 - 6$

b.  $x - 4 + \frac{4}{x - 2}$

c.  $x - 6 - \frac{12}{x - 2}$

d.  $x - 4 - \frac{4}{x - 2}$

**Add or subtract.**

43.  $\frac{8}{x + 3} - \frac{3}{x - 2}$

a.  $\frac{5x}{(x + 3)(x - 2)}$

b.  $\frac{5x - 25}{(x + 3)(x - 2)}$

c.  $\frac{5x + 25}{(x + 3)(x - 2)}$

d.  $\frac{-5x - 25}{(x + 3)(x - 2)}$

44.  $\frac{5}{x - 4} + \frac{3}{x + 4}$

a.  $\frac{8x - 8}{(x - 4)(x + 4)}$

b.  $\frac{-8x + 8}{(x - 4)(x + 4)}$

c.  $\frac{8x}{(x - 4)(x + 4)}$

d.  $\frac{8x + 8}{(x - 4)(x + 4)}$

**Solve the equation.**

45.  $\frac{5}{x} + \frac{3}{x} = 5$

a.  $x = -\frac{2}{5}$

b.  $x = \frac{2}{5}$

c.  $x = \frac{8}{5}$

d.  $x = \frac{5}{8}$

46.  $\frac{1}{x - 1} - \frac{1}{x + 1} = \frac{1}{12}$

a.  $x = -\sqrt{11}, \sqrt{23}$

b.  $x = -\sqrt{23}, \sqrt{11}$

c.  $x = -5, 5$

d.  $x = 5$

47.  $\frac{a}{a^2 - 36} + \frac{2}{a - 6} = \frac{1}{a + 6}$

a.  $-9$

b.  $-6$

c.  $-9$  and  $-6$

d.  $6$

48.  $\frac{6}{x^2 - 9} - \frac{1}{x - 3} = 1$

a. -4

b. 2

c.  $\frac{-1 \pm \sqrt{73}}{2}$

d. 3 or -4

Solve the proportion.

49.  $\frac{5}{x + 4} = \frac{4x - 3}{x^2 - 16}$

a.  $x = 17$

b.  $x = 4, -4$

c.  $x = 17, -4$

d.  $x = 17, 4, -4$

50. What is the graph of  $y = \frac{3}{x}$ ?

a.

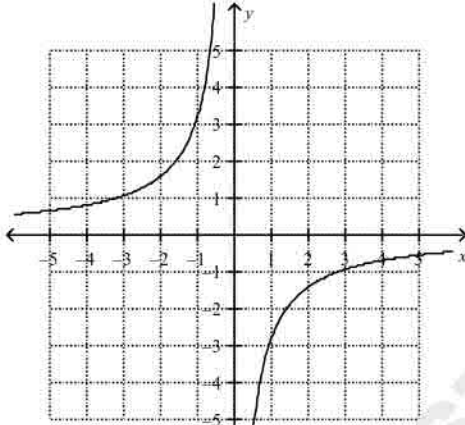

c.

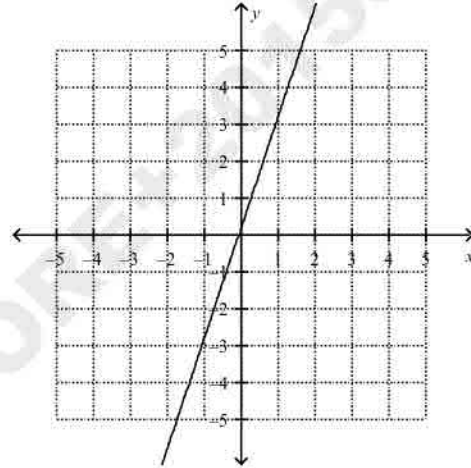

b.

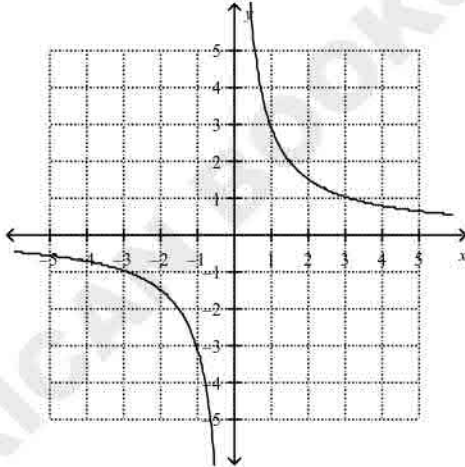

d.

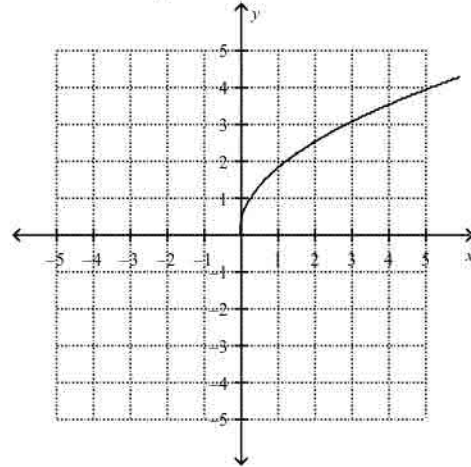

51. What is the graph of  $y = -\frac{2}{x}$ ?

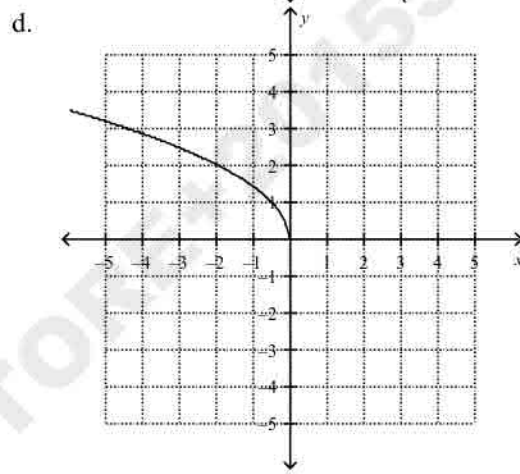
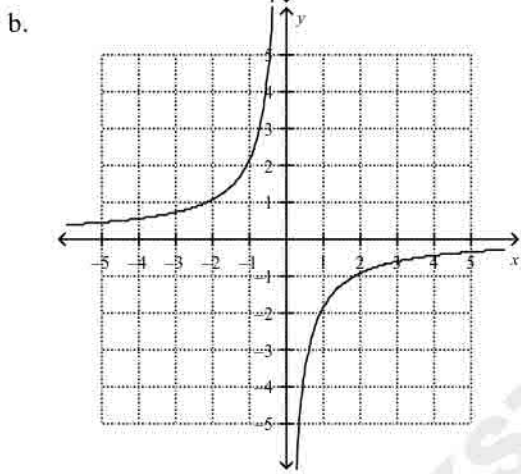
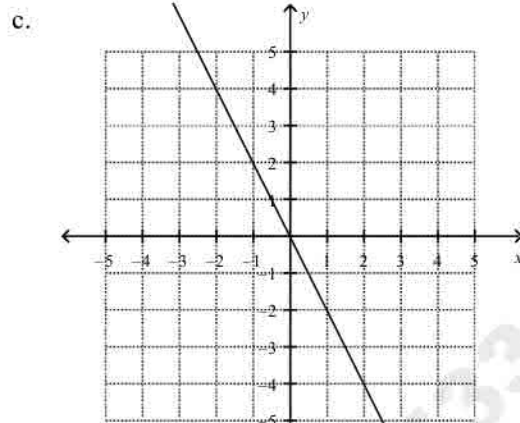
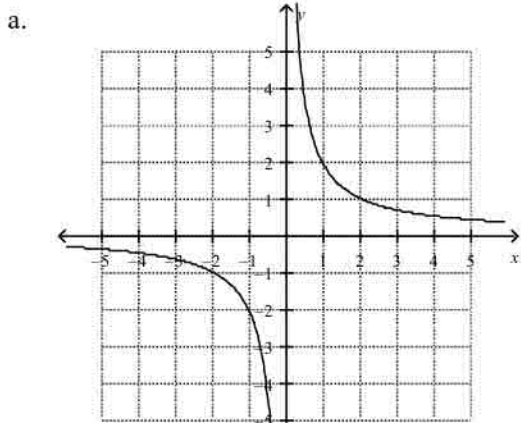

Graph the function and identify the vertical asymptote.

52.  $y = \frac{1}{x-1} - 3$

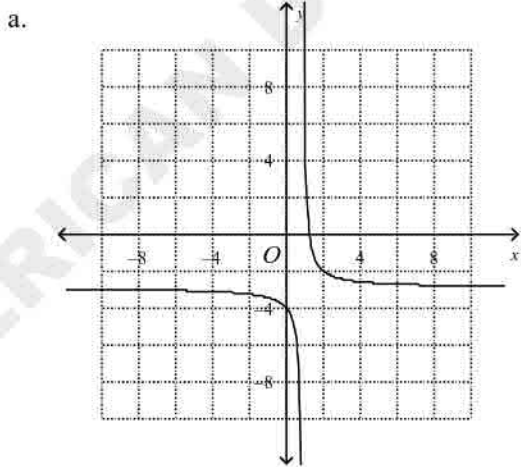

$x = 1$

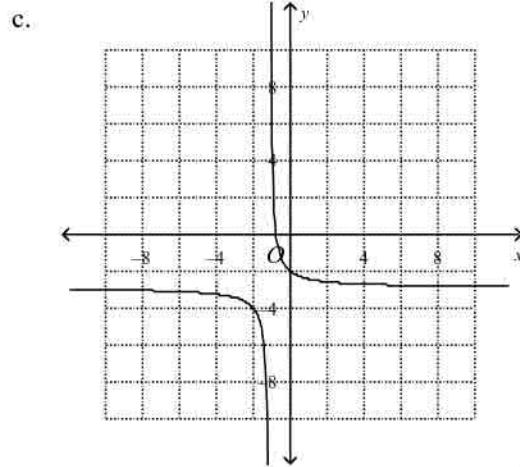

$x = -1$

$y = -1$

b.

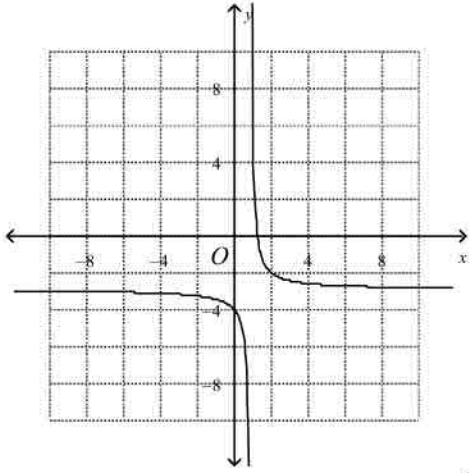

d.

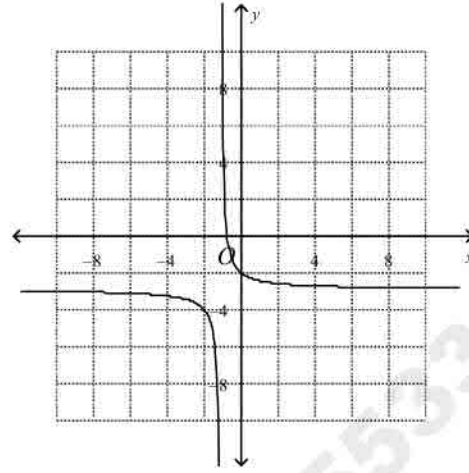

$= 1$

$x = -1$

53.  $y = \frac{1}{x+1} - 2$

a.

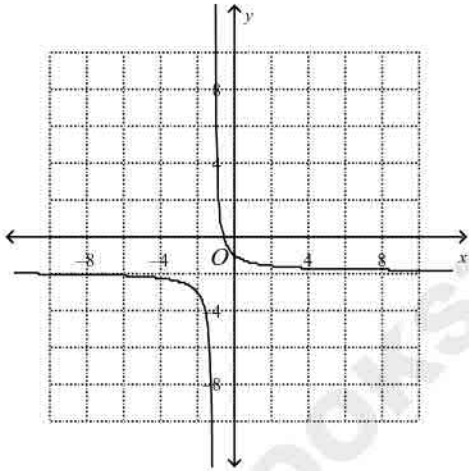

c.

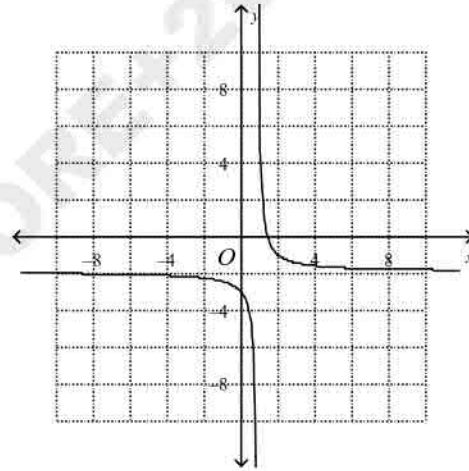

$x = -1$

$x = 1$

b.

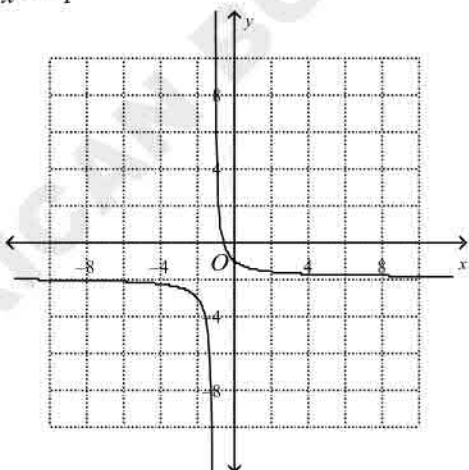

d.

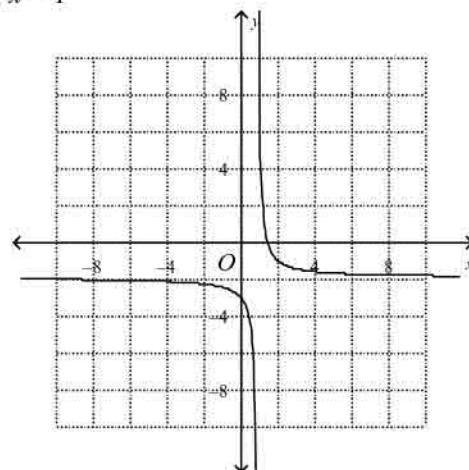

$= -1$

$= 1$

What is the graph of the function?

54.  $f(x) = 2x^2$

a.

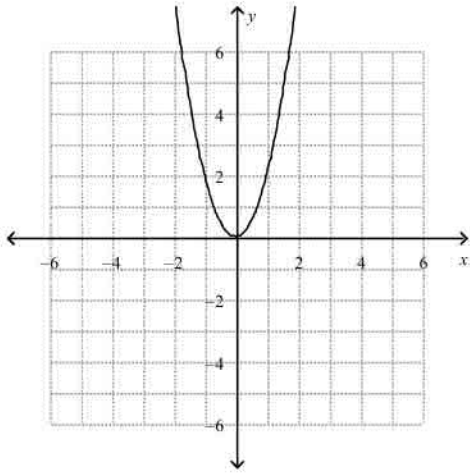

c.

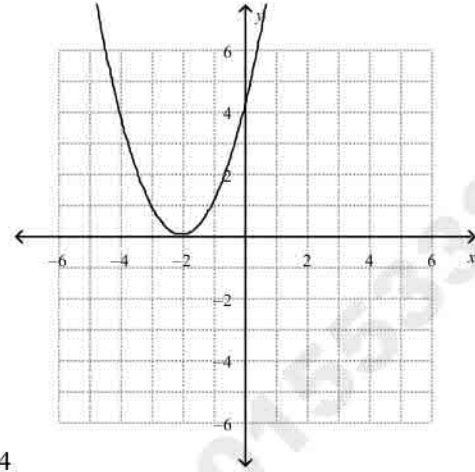

4

b.

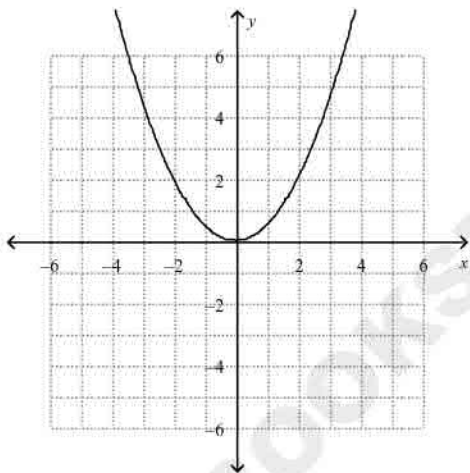

d.

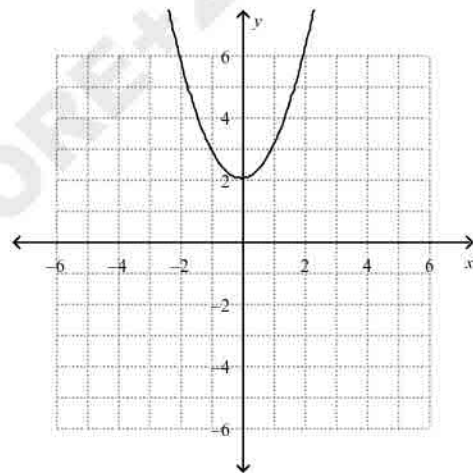

55.  $f(x) = \frac{1}{3}x^2$

a.

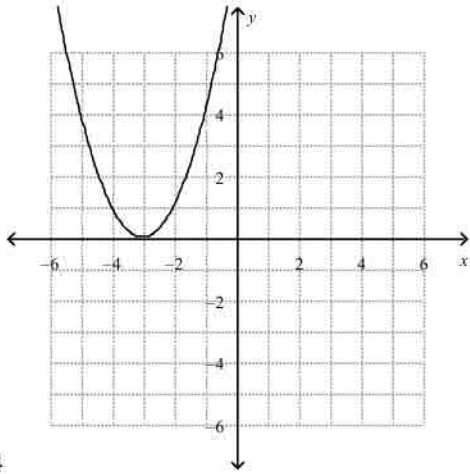

4

c.

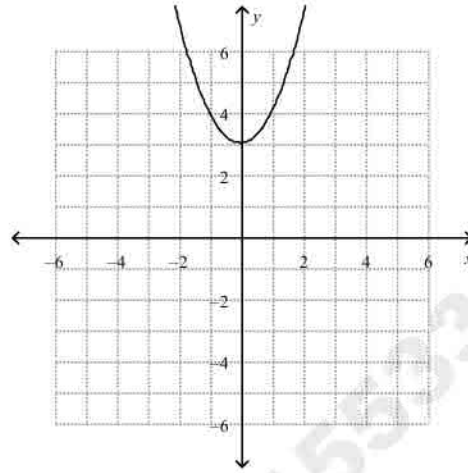

b.

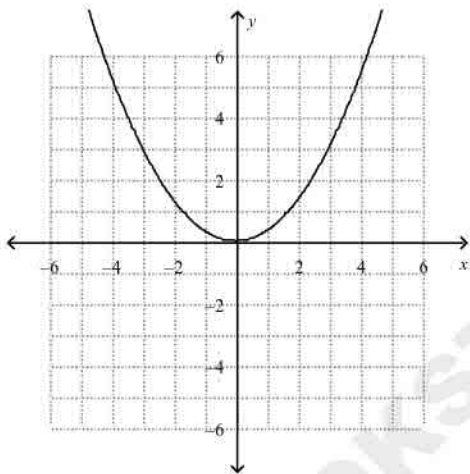

d.

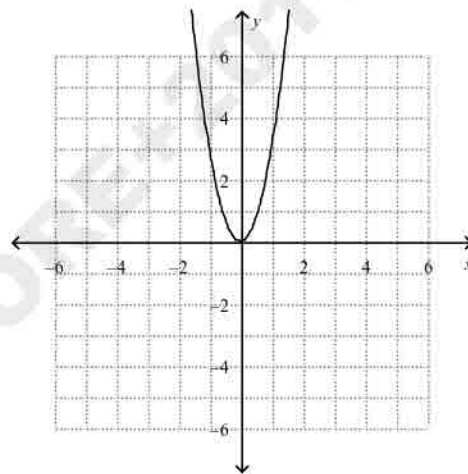

Graph each function. How is each graph a translation of  $f(x) = x^2$ ?

56.  $y = x^2 - 5$

a.

c.

AMERICAN BOOKSTORE 1553389184

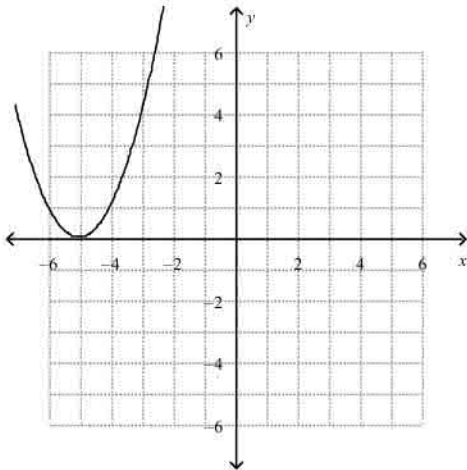

$f(x)$  translated to the left 5 unit(s)

b.

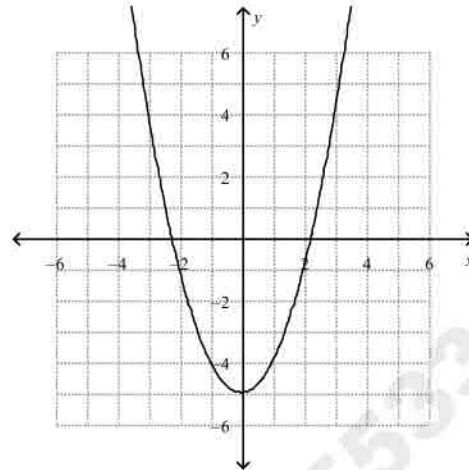

$f(x)$  translated down 5 unit(s)

d.

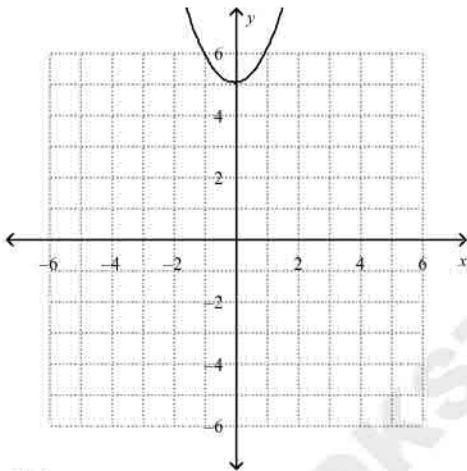

$f(x)$  translated up 5 unit(s)

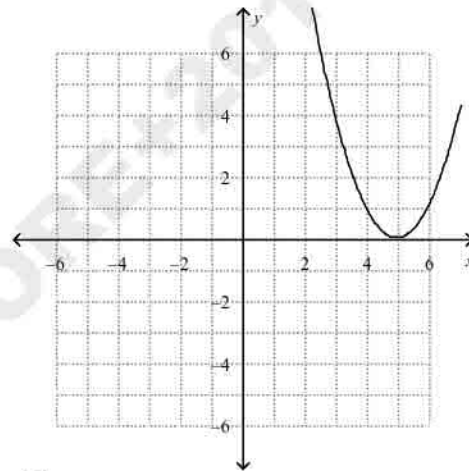

$f(x)$  translated to the right 5 unit(s)

57.  $y = (x - 2)^2$

a.

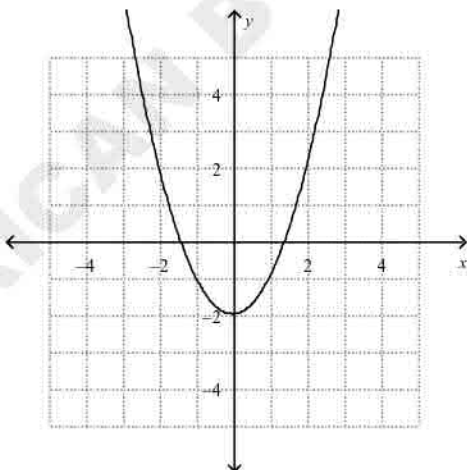

$f(x)$  translated down 2 unit(s)

b.

c.

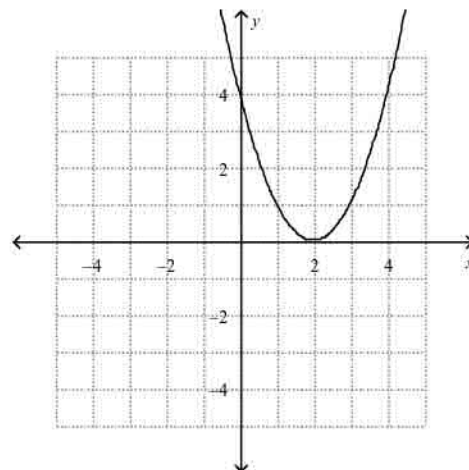

$f(x)$  translated to the right 2 unit(s)

d.

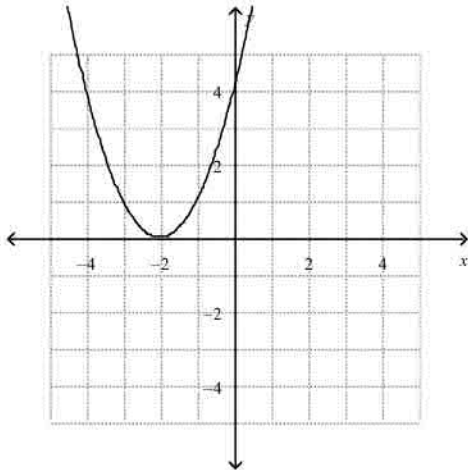

$f(x)$  translated to the left 2 unit(s)

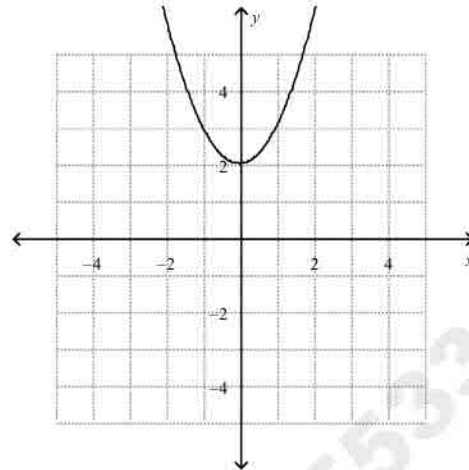

$f(x)$  translated up 2 unit(s)

58.  $y = (x + 3)^2 + 4$

a.

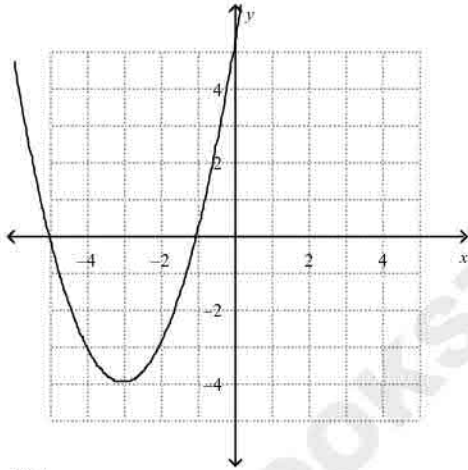

$f(x)$  translated down 4 unit(s) and translated to the left 3 unit(s)

b.

c.

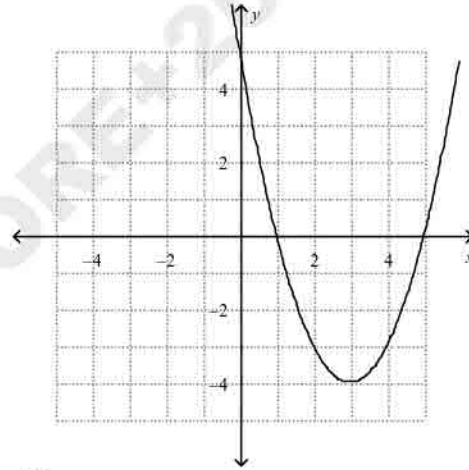

$f(x)$  translated down 4 unit(s) and translated to the right 3 unit(s)

d.

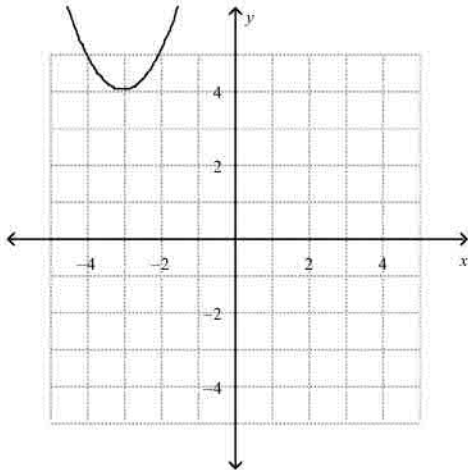

$f(x)$  translated up 4 unit(s) and translated to the left 3 unit(s).

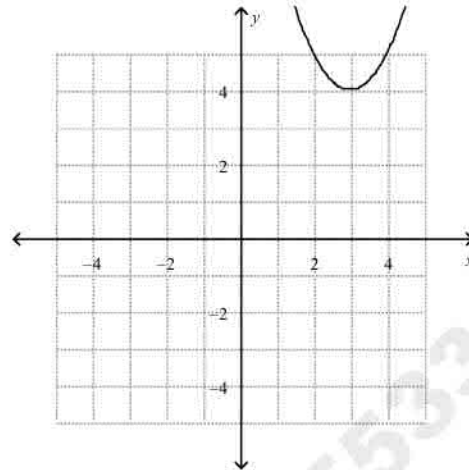

$f(x)$  translated up 4 unit(s) and translated to the right 3 unit(s).

59. Identify the vertex and the axis of symmetry of the graph of the function  $y = 2(x + 2)^2 - 4$ .
- vertex:  $(-2, 4)$ ;  
axis of symmetry:  $x = -2$
  - vertex:  $(2, -4)$ ;  
axis of symmetry:  $x = 2$
  - vertex:  $(-2, -4)$ ;  
axis of symmetry:  $x = -2$
  - vertex:  $(2, 4)$ ;  
axis of symmetry:  $x = 2$
60. Identify the maximum or minimum value and the domain and range of the graph of the function  $y = 2(x + 2)^2 - 3$ .
- minimum value: 3  
domain: all real numbers  $\geq 3$   
range: all real numbers
  - maximum value:  $-3$   
domain: all real numbers  $\leq -3$   
range: all real numbers
  - maximum value: 3  
domain: all real numbers  
range: all real numbers  $\leq 3$
  - minimum value:  $-3$   
domain: all real numbers  
range: all real numbers  $\geq -3$

**What is the graph of the equation?**

61.  $y = -2x^2 + 2x + 2$

a.

c.

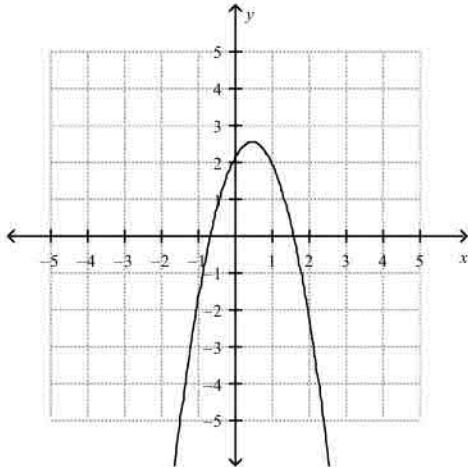

b.

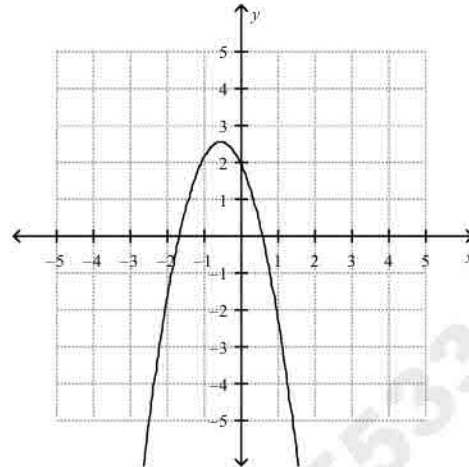
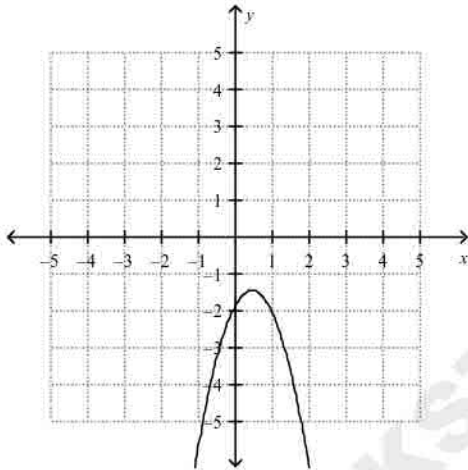

d.

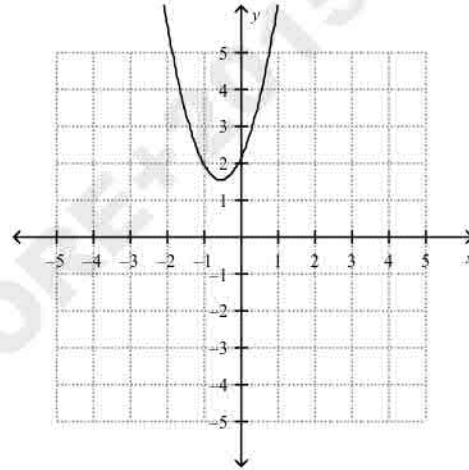

What is the vertex form of the equation?

62.  $y = x^2 - 2x + 8$

a.  $y = (x + 1)^2 + 7$

b.  $y = (x + 1)^2 - 7$

c.  $y = (x - 1)^2 + 7$

d.  $y = (x - 1)^2 - 7$

63.  $y = x^2 + 8x - 6$

a.  $y = (x - 4)^2 - 22$

b.  $y = (x - 4)^2 + 22$

c.  $y = (x + 4)^2 - 22$

d.  $y = (x + 4)^2 + 22$

What is the expression in factored form?

64.  $x^2 - 6x + 8$

a.  $(x + 4)(x + 2)$

b.  $(x - 2)(x - 4)$

c.  $(x - 4)(x + 2)$

d.  $(x - 2)(x + 4)$

What is the number of real solutions?

65.  $-x^2 + 9x + 7 = 0$

- a. one solution
- b. no real solutions
- c. two solutions
- d. cannot be determined

66.  $8x^2 - 11x = -3$

- a. one real solution
- b. two real solutions
- c. no real solutions
- d. cannot be determined

67.  $x^2 = -7x + 7$

- a. one solution
- b. no real solutions
- c. two solutions
- d. cannot be determined

Simplify the number using the imaginary unit  $i$ .

68.  $\sqrt{-144}$

- a. 12
- b. -12
- c.  $12i$
- d.  $144i$

69.  $\sqrt{-360}$

- a.  $6\sqrt{-10}$
- b.  $6i\sqrt{10}$
- c.  $i\sqrt{360}$
- d.  $-6\sqrt{10}$

70. Identify the graph of  $-1 + 2i$ .

a.

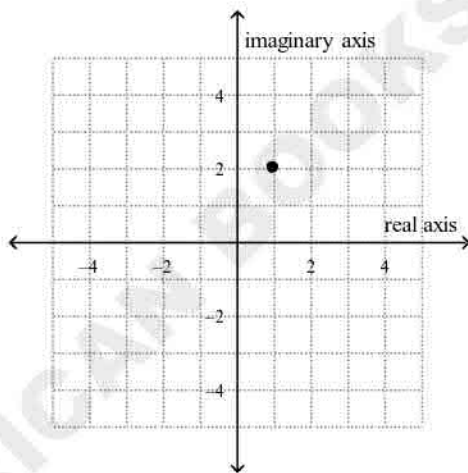

b.

c.

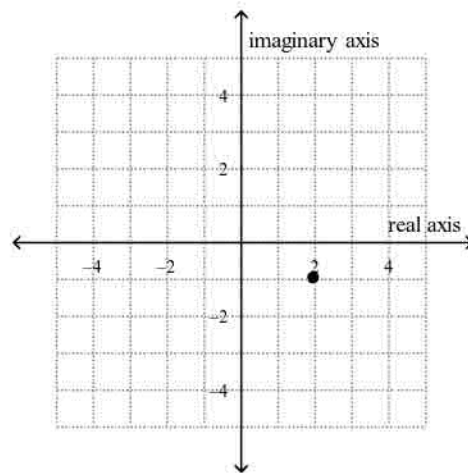

d.

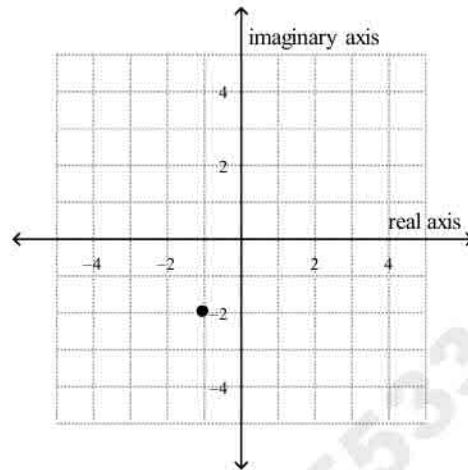
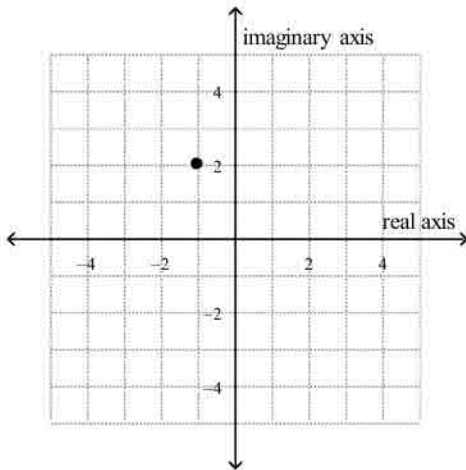

71. Identify the graph of  $-2i$

a.

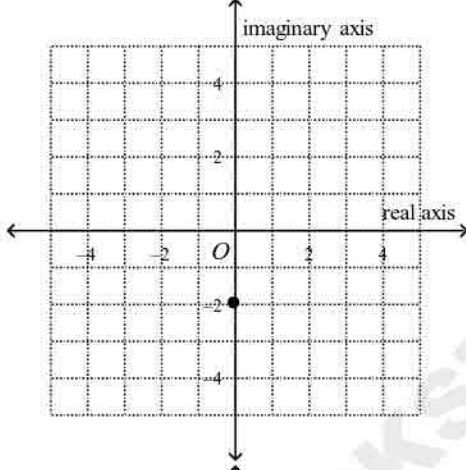

b.

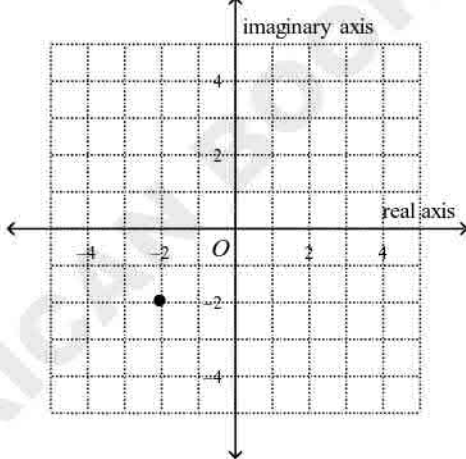

c.

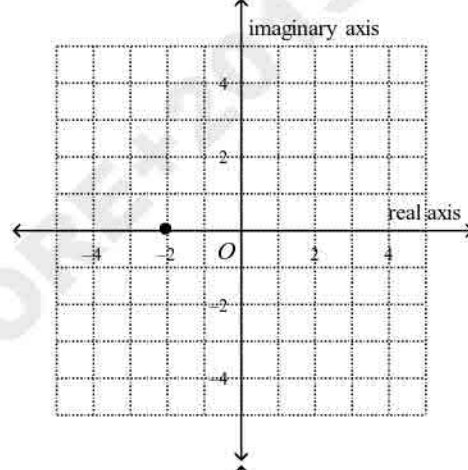

d.

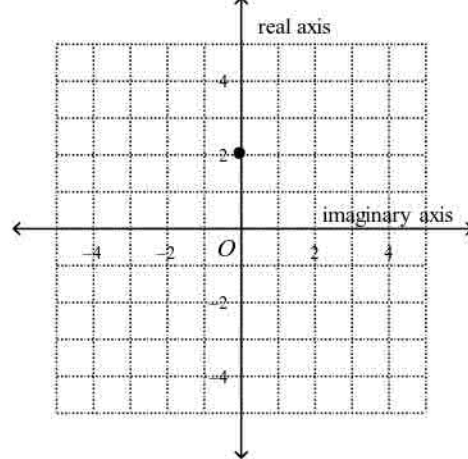

What is the absolute value of each number?

72.  $-1 + 3i$ .

a. 2

b. -8

c.  $\sqrt{10}$

d.  $\sqrt{-3}$

- \_\_\_ 73.  $-3i$   
 a.  $-3$   
 b.  $-9$   
 c.  $3$   
 d.  $\sqrt{0}$

**Simplify the expression.**

- \_\_\_ 74.  $(-1 + 6i) + (-4 + 2i)$   
 a.  $5 - 8i$   
 b.  $5 - 2i$   
 c.  $-5 + 8i$   
 d.  $3i$
- \_\_\_ 75.  $(1 + 2i) - (5 + 3i)$   
 a.  $-5i$   
 b.  $-4 - i$   
 c.  $6 + 5i$   
 d.  $4 + i$
- \_\_\_ 76.  $(-5i)(6i)$   
 a.  $-30$   
 b.  $-30i$   
 c.  $30$   
 d.  $30i$
- \_\_\_ 77.  $(6 - 4i)(-1 + 6i)$   
 a.  $-6 - 24i$   
 b.  $18 + 40i$   
 c.  $-6 + 40i$   
 d.  $-30 + 40i$
- \_\_\_ 78.  $\frac{-1 + 3i}{4 - i}$   
 a.  $\frac{-7 - 13i}{17}$   
 b.  $\frac{-7 + 11i}{15}$   
 c.  $\frac{-1 + 11i}{17}$   
 d.  $\frac{-7 + 11i}{17}$
- \_\_\_ 79.  $\frac{-5 + 4i}{-6i}$   
 a.  $\frac{-24 - 30i}{-36}$   
 b.  $\frac{-24 - 30i}{36}$   
 c.  $\frac{24 - 30i}{36}$   
 d.  $\frac{-24 - 30i}{36}$

**Graph the exponential function.**

- \_\_\_ 80.  $y = 4^x$

a.

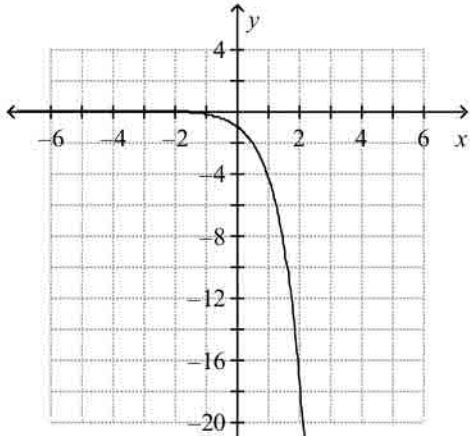

c.

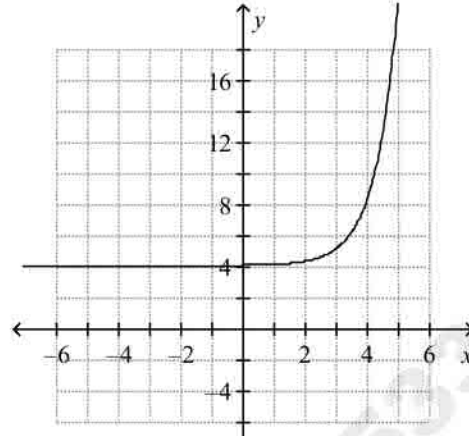

b.

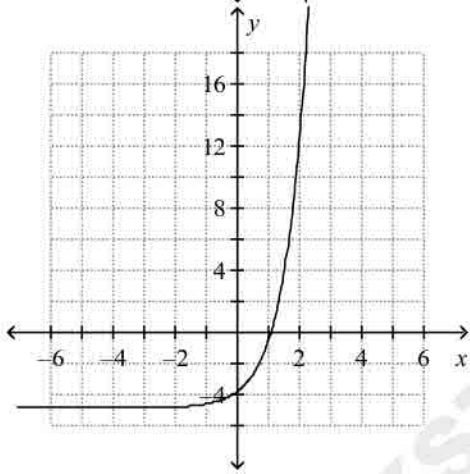

d.

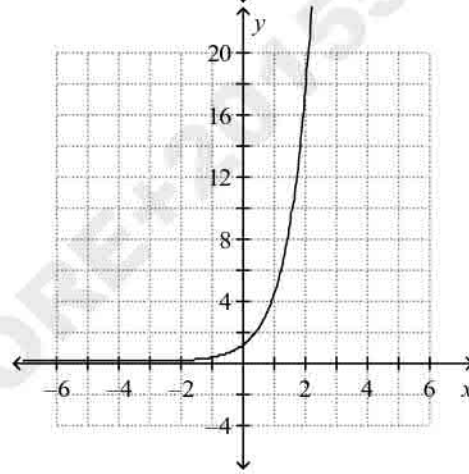

81.  $y = 4(3)^x$

a.

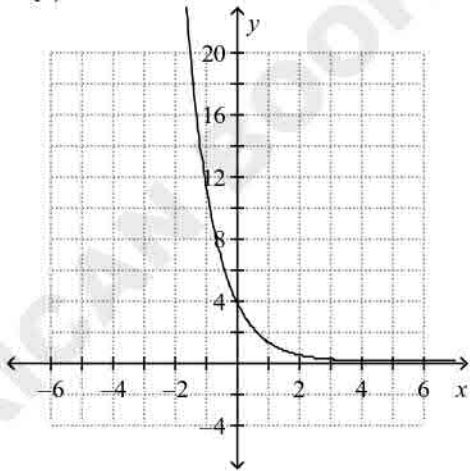

c.

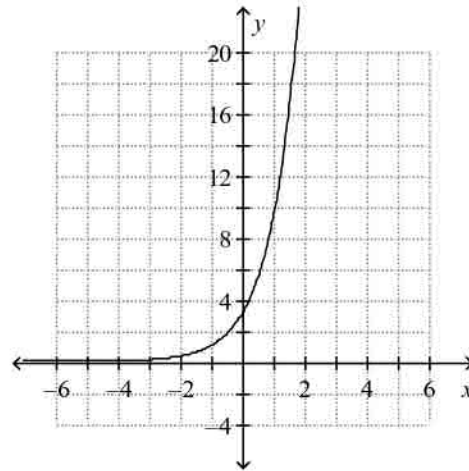

b.

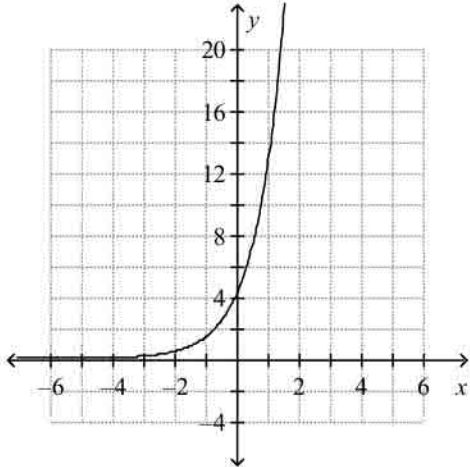

d.

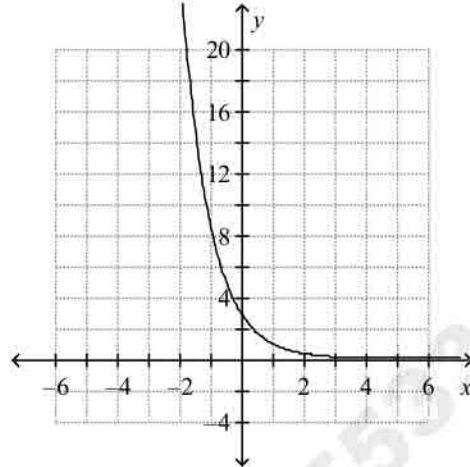

82.  $y = 3(1.9)^x$

a.

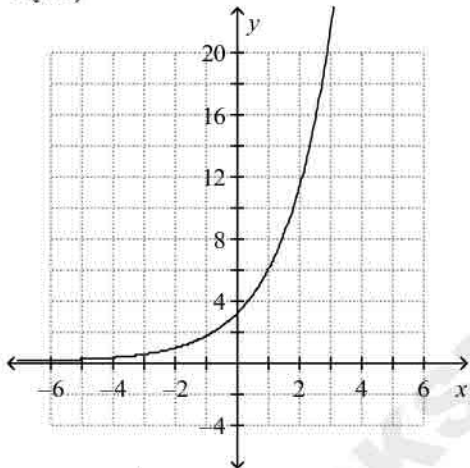

c.

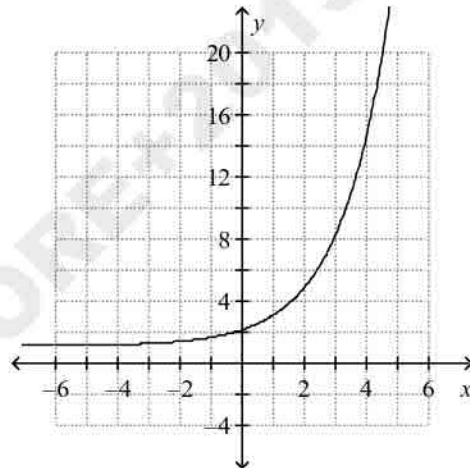

b.

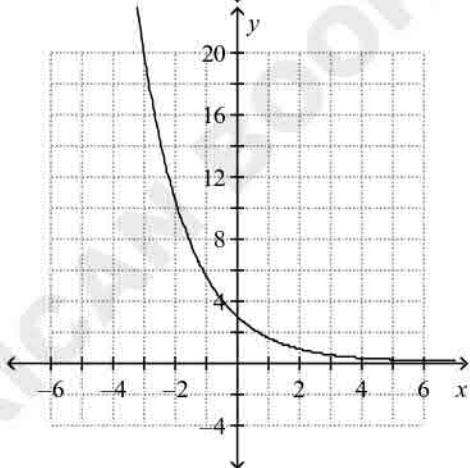

d.

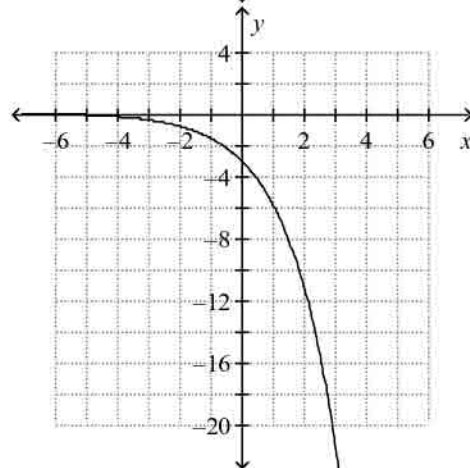

83. Find the annual percent increase or decrease that  $y = 0.35(2.3)^x$  models.

- a. 230% increase
- b. 130% increase
- c. 30% decrease
- d. 65% decrease

84. An initial population of 820 quail increases at an annual rate of 23%. Write an exponential function to model the quail population. What will the approximate population be after 3 years?

- a.  $f(x) = 820(1.23)^x$ ; 1526
- b.  $f(x) = 820(1.23)^x$ ; 1526
- c.  $f(x) = (820 \cdot 0.23)^x$ ; 6,708,494
- d.  $f(x) = (820 \cdot 0.23)^x$ ; 6,708,494

b.  $f(x) = 820(23)^x$ ; 9,976,940

d.  $f(x) = 820(0.23)^x$ ; 1526

85. The half-life of a certain radioactive material is 32 days. An initial amount of the material has a mass of 361 kg. Write an exponential function that models the decay of this material. Find how much radioactive material remains after 5 days. Round your answer to the nearest thousandth.

a.  $y = 361\left(\frac{1}{2}\right)^{\frac{32x}{32}}$ ; 0 kg

c.  $y = 2\left(\frac{1}{361}\right)^{\frac{1}{32}x}$ ; 0.797 kg

b.  $y = 361\left(\frac{1}{2}\right)^{\frac{1}{32}x}$ ; 323.945 kg

d.  $y = \frac{1}{2}\left(\frac{1}{361}\right)^{\frac{1}{32}x}$ ; 0.199 kg

86. The half-life of a certain radioactive material is 71 hours. An initial amount of the material has a mass of 722 kg. Write an exponential function that models the decay of this material. Find how much radioactive material remains after 17 hours. Round your answer to the nearest thousandth.

a.  $y = \frac{1}{2}\left(\frac{1}{722}\right)^{\frac{1}{71}x}$ ; 0.103 kg

c.  $y = 2\left(\frac{1}{722}\right)^{\frac{1}{71}x}$ ; 0.414 kg

b.  $y = 722\left(\frac{1}{2}\right)^{\frac{1}{71}x}$ ; 611.589 kg

d.  $y = 722\left(\frac{1}{2}\right)^{71x}$ ; 0 kg

**Solve the exponential equation.**

87.  $\frac{1}{16} = 64^{4x-3}$

a.  $\frac{1}{12}$

b.  $\frac{1}{4}$

c.  $\frac{7}{12}$

d.  $\frac{11}{12}$

88.  $4^{4x} = 8$

a.  $\frac{3}{4}$

b.  $\frac{8}{3}$

c.  $\frac{3}{8}$

d. 2

**Is the relationship between the variables in the table a direct variation, an inverse variation, or neither? If it is a direct or inverse variation, write a function to model it.**

89.

$x$	-9	-7	-2	-1
$y$	36	28	8	4

a. inverse variation;  $y = \frac{-324}{x}$

b. direct variation;  $y = -4x$

c. neither

90.

$x$	9	11	13	15
$y$	-17	-1	6	27

a. inverse variation;  $y = \frac{-153}{x}$

b. direct variation;  $y = -\frac{17}{9}x$

c. neither

91. Suppose that  $x$  and  $y$  vary inversely and that  $y = \frac{8}{3}$  when  $x = 8$ . Write a function that models the inverse variation and find  $y$  when  $x = 4$ .

a.  $y = \frac{1}{3x}; \frac{1}{24}$

c.  $y = \frac{8}{3x}; \frac{8}{3}$

b.  $y = \frac{8}{3x}; \frac{16}{3}$

d.  $y = \frac{64}{3x}; \frac{16}{3}$

Find any points of discontinuity for the rational function.

92.  $y = \frac{(x+3)(x-5)(x+7)}{(x+1)(x+4)}$

a.  $x = 1, x = 4$

c.  $x = 3, x = -5, x = 7$

b.  $x = -1, x = -4$

d.  $x = -3, x = 5, x = -7$

93.  $y = \frac{x+8}{x^2-9x+14}$

a.  $x = -2, x = -7$

c.  $x = -8$

b.  $x = 2, x = -7$

d.  $x = 2, x = 7$

94. What are the points of discontinuity? Are they all removable?

$y = \frac{(x-7)(x-3)}{x^2-10x+21}$

a.  $x = 1, x = -8, x = -2$ ; yes

c.  $x = -7, x = -3$ ; no

b.  $x = 7, x = 3$ ; yes

d.  $x = -1, x = 8, x = 2$ ; no

95. What are the points of discontinuity? Are they all removable?

$y = \frac{(x-5)}{x^2-6x+5}$

a.  $x = -1, x = -5, x = 8$ ; yes

c.  $x = -1, x = -5$ ; no

b.  $x = 6, x = -7, x = -8$ ; no

d.  $x = 1, x = 5$ ; no

Simplify the sum.

96.  $\frac{a^2+7a+10}{a^2+2a-15} + \frac{10}{a-3}$

a.  $\frac{a+12}{a-3}$

c.  $\frac{a^2+7a+20}{a^2+2a-15}$

b.  $\frac{a+2}{a-3}$

d.  $a+12$

97.  $\frac{d^2 + d - 30}{d^2 + 3d - 40} + \frac{d^2 + 14d + 48}{d^2 - 2d - 48}$

a.  $\frac{2d^2 + 15d + 18}{2d^2 + d - 88}$

b.  $\frac{d^2 + 14d + 16}{(d + 8)(d - 8)}$

c.  $\frac{2d^2 + 14d + 16}{(d + 8)(d - 8)}$

d.  $\frac{2d^2 + 15d + 18}{(d + 8)(d - 8)}$

AMERICAN BOOKSTORE+201553389184

Answer Section

MULTIPLE CHOICE

1. B
2. D
3. C
4. A
5. A
6. A
7. A
8. A
9. D
10. C
11. C
12. B
13. B
14. B
15. B
16. D
17. B
18. B
19. D
20. C
21. C
22. C
23. A
24. D
25. D
26. C
27. B
28. A
29. D
30. B
31. B
32. C
33. C
34. D
35. C
36. D
37. B
38. C
39. C
40. C
41. B
42. B
43. B
44. D
45. C

- 46. C
- 47. A
- 48. A
- 49. A
- 50. B
- 51. B
- 52. A
- 53. A
- 54. A
- 55. B
- 56. C
- 57. C
- 58. B
- 59. C
- 60. D
- 61. A
- 62. C
- 63. C
- 64. B
- 65. C
- 66. B
- 67. A
- 68. C
- 69. B
- 70. B
- 71. A
- 72. C
- 73. C
- 74. C
- 75. B
- 76. C
- 77. B
- 78. D
- 79. B
- 80. D
- 81. B
- 82. A
- 83. B
- 84. A
- 85. B
- 86. B
- 87. C
- 88. C
- 89. B
- 90. C
- 91. D
- 92. B
- 93. D
- 94. B
- 95. D
- 96. A



**Multiple Choice**

Identify the choice that best completes the statement or answers the question.

Use the diagram to find the following.

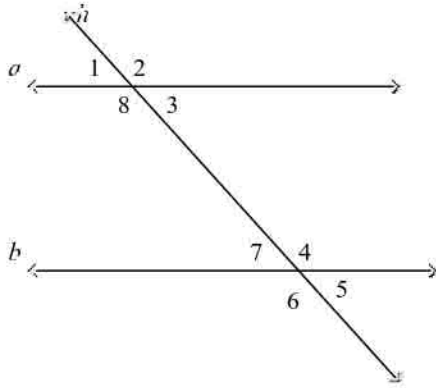

- \_\_\_ 1. Identify a pair of alternate exterior angles.
- a.  $\angle 3$  and  $\angle 4$
  - b.  $\angle 1$  and  $\angle 2$
  - c.  $\angle 1$  and  $\angle 6$
  - d.  $\angle 2$  and  $\angle 6$
- \_\_\_ 2. Which angles are corresponding angles?

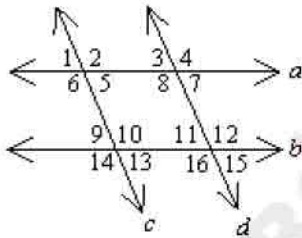

- a.  $\angle 8$  and  $\angle 16$
  - b.  $\angle 7$  and  $\angle 8$
  - c.  $\angle 4$  and  $\angle 8$
  - d. none of these
- \_\_\_ 3. What is the relationship between  $\angle 3$  and  $\angle 6$ ?

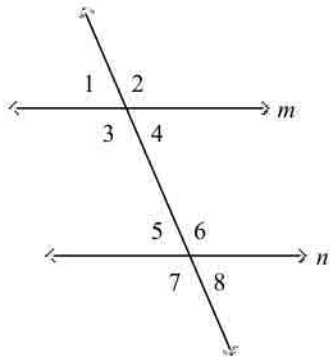

- a. corresponding angles
- b. same-side interior angles
- c. alternate interior angles
- d. alternate exterior angles

This diagram of airport runway intersections shows two parallel runways. A taxiway crosses both runways.

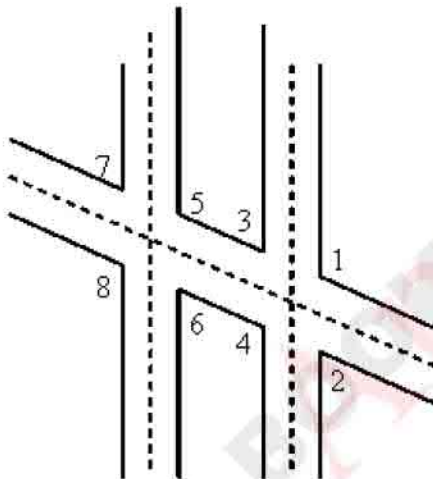

- 4. How are  $\angle 6$  and  $\angle 2$  related?
  - a. corresponding angles
  - b. alternate interior angles
  - c. same-side interior angles
  - d. none of these
- 5. Find  $m\angle Q$ . The diagram is not to scale.

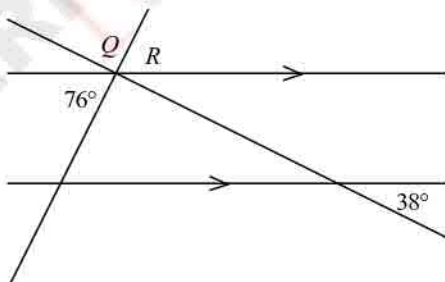

- a. 76                      b. 104                      c. 66                      d. 114

6. Find the values of  $x$  and  $y$ . The diagram is not to scale.

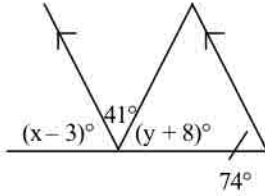

- a.  $x = 77, y = 59$                       c.  $x = 57, y = 77$   
 b.  $x = 77, y = 57$                       d.  $x = 41, y = 57$

7. State whether  $\triangle ABC$  and  $\triangle AED$  are congruent. Justify your answer.

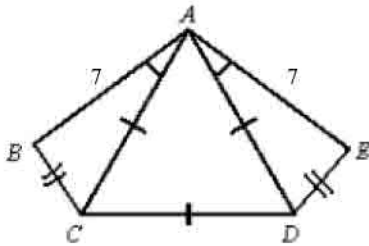

- a. yes, by either SSS or SAS  
 b. yes, by SSS only  
 c. yes, by SAS only  
 d. No; there is not enough information to conclude that the triangles are congruent.

8. Which pair of triangles is congruent by ASA?

a.

b.

c.

d.

9. Name the theorem or postulate that lets you immediately conclude  $\triangle ABD \cong \triangle CBD$ .

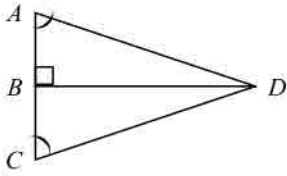

- a. AAS                      b. SAS                      c. ASA                      d. none of these

10. Find the value of  $x$ .

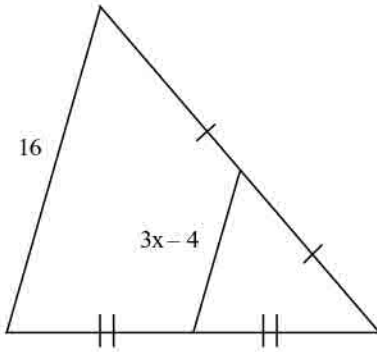

- a. 4                      b. 8                      c. 6.6                      d. 6

11. Find the value of  $x$ . The diagram is not to scale.

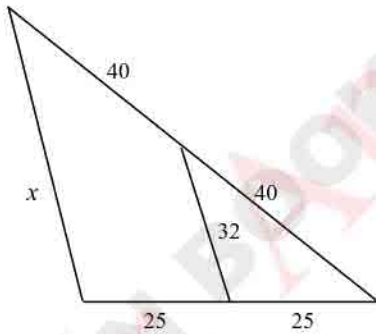

- a. 32                      b. 50                      c. 64                      d. 80

12. Find the length of the midsegment. The diagram is not to scale.

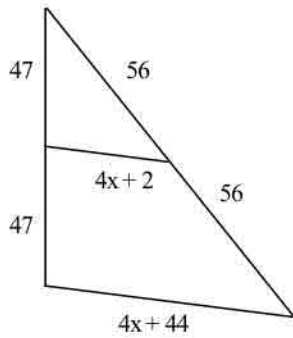

- a. 24                      b. 0                      c. 42                      d. 84

13. Use the information in the diagram to determine the height of the tree. The diagram is not to scale.

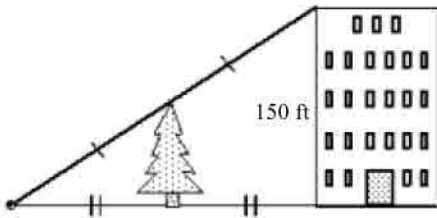

- a. 75 ft                      b. 150 ft                      c. 35.5 ft                      d. 37.5 ft

14. Use the information in the diagram to determine the measure of the angle formed by the line from the point on the ground to the top of the building and the side of the building. The diagram is not to scale.

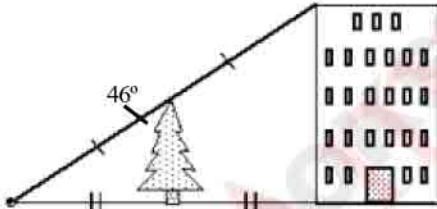

- a.  $46^\circ$                       b.  $23^\circ$                       c.  $92^\circ$                       d.  $44^\circ$

15. A triangular side of the Transamerica Pyramid Building in San Francisco, California, is 149 feet at its base. If the distance from a base corner of the building to its peak is 859 feet, how wide is the triangle halfway to the top?

Transamerica Pyramid

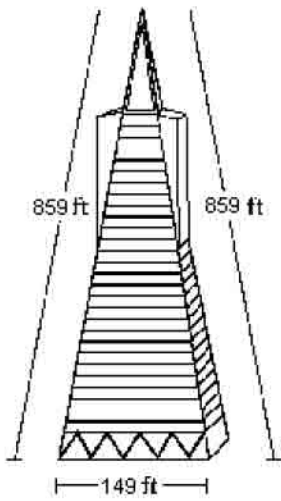

- a. 298 ft      b. 74.5 ft      c. 149 ft      d. 429.5 ft

16.  $Q$  is equidistant from the sides of  $\angle TSR$ . Find  $m\angle RST$ . The diagram is not to scale.

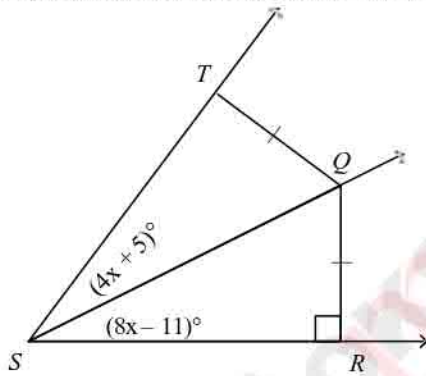

- a. 21      b. 42      c. 4      d. 8

17. Find the length of  $\overline{AB}$ , given that  $\overline{DB}$  is a median of the triangle and  $AC = 26$ .

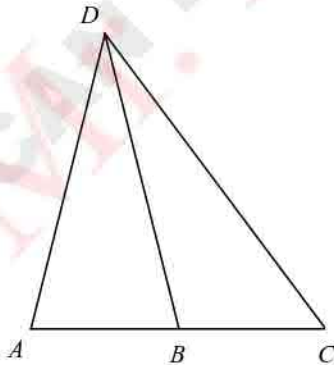

- a. 13      c. 52  
b. 26      d. not enough information

18. Find the sum of the measures of the angles of the figure.

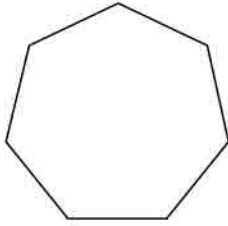

19. The sum of the angle measures of a polygon with  $s$  sides is 2520. Find  $s$ .  
 a. 900                      b. 1080                      c. 1620                      d. 1260
20. The Polygon Angle-Sum Theorem states: The sum of the measures of the angles of an  $n$ -gon is \_\_\_\_\_.  
 a.  $\frac{n-2}{180}$                       b.  $(n-1)180$                       c.  $\frac{180}{n-1}$                       d.  $(n-2)180$
21. Complete this statement: A polygon with all sides the same length is said to be \_\_\_\_\_.  
 a. regular                      b. equilateral                      c. equiangular                      d. convex
22. Find the value of  $x$ . The diagram is not to scale.

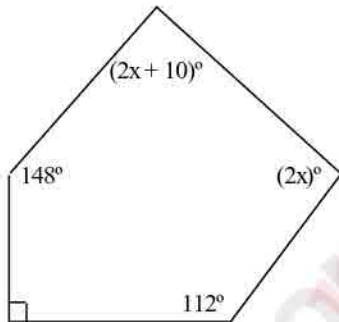

23. Find  $m\angle A$ . The diagram is not to scale.

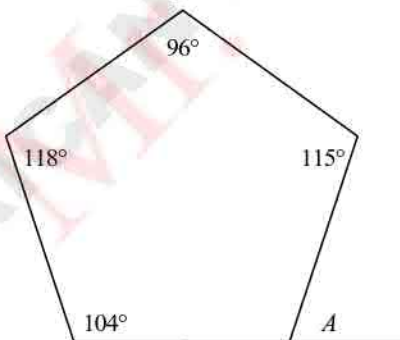

24. How many sides does a regular polygon have if each exterior angle measures 20°?  
 a. 17 sides                      b. 20 sides                      c. 21 sides                      d. 18 sides

25. In the figure, the horizontal lines are parallel and  $AB = BC = CD$ . Find  $KL$  and  $FG$ . The diagram is not to scale.

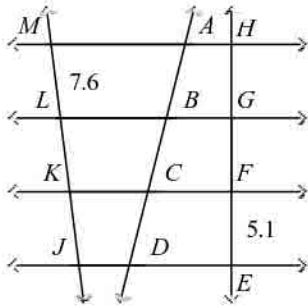

- a.  $KL = 7.6, FG = 7.6$                       c.  $KL = 5.1, FG = 5.1$   
 b.  $KL = 5.1, FG = 7.6$                       d.  $KL = 7.6, FG = 5.1$
26.  $\overline{LM}$  is the midsegment of  $\square ABCD$ .  $AB = 46$  and  $DC = 125$ . What is  $LM$ ?

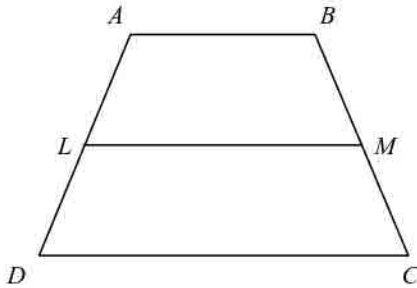

- a. 171                      b. 85.5                      c. 79                      d. 95.5
27.  $\overline{LM}$  is the midsegment of  $\square ABCD$ .  $AB = x + 8$ ,  $LM = 4x + 3$ , and  $DC = 201$ . What is the value of  $x$ ?

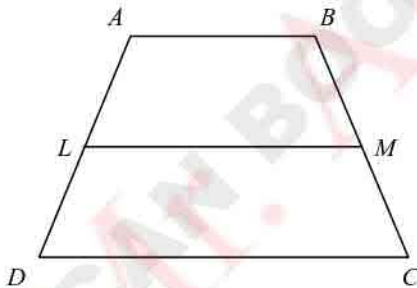

- a. 33                      b. 29                      c. 238                      d. 37
28. Which diagram shows the most useful positioning and accurate labeling of a kite in the coordinate plane?

a.

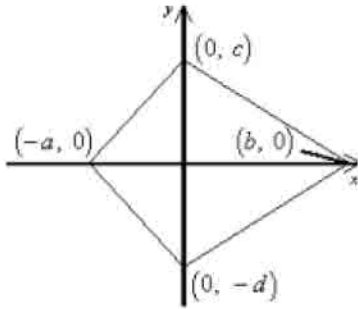

c.

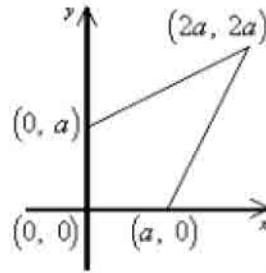

b.

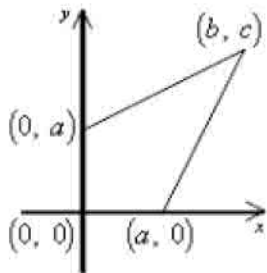

d.

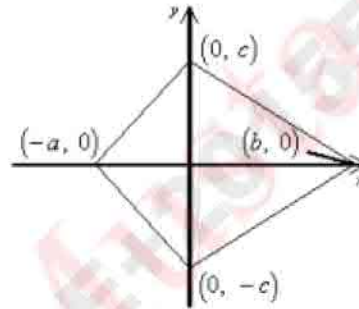

29. Which diagram shows the most useful positioning of a square in the first quadrant of a coordinate plane?

a.

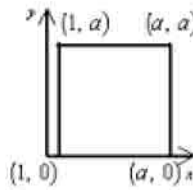

c.

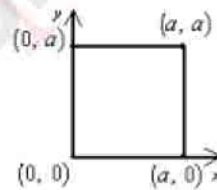

b.

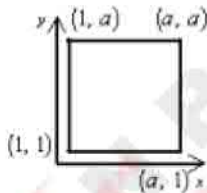

d.

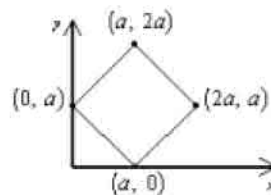

30. A model is made of a car. The car is 9 feet long and the model is 6 inches long. What is the ratio of the length of the car to the length of the model?

- a. 18 : 1      b. 1 : 18      c. 9 : 6      d. 6 : 9

31. The Sears Tower in Chicago is 1450 feet high. A model of the tower is 24 inches tall. What is the ratio of the height of the model to the height of the actual Sears Tower?

- a. 1 : 725      b. 725 : 1      c. 12 : 725      d. 725 : 12

32. Red and grey bricks were used to build a decorative wall. The  $\frac{\text{number of red bricks}}{\text{number of grey bricks}}$  was  $\frac{5}{2}$ . There were 175 bricks used in all. How many red bricks were used?

- a. 25      c. 50  
b. 125      d. 35



b.  $a = 18, b = 2\sqrt{17}$

d.  $a = 64, b = 68$

39. Find the length of the altitude drawn to the hypotenuse. The triangle is not drawn to scale.

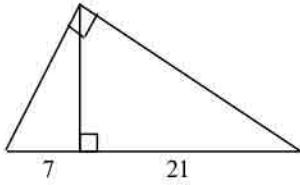

a. 28

b.  $7\sqrt{3}$

c. 147

d.  $2\sqrt{7}$

40. Jason wants to walk the shortest distance to get from the parking lot to the beach.

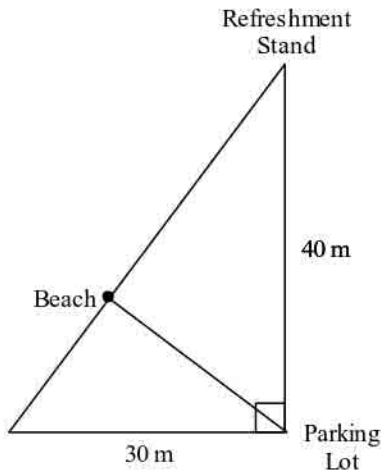

a. How far is the spot on the beach from the parking lot?

b. How far will his place on the beach be from the refreshment stand?

a. 24 m; 32 m

c. 34 m; 16 m

b. 38 m; 12 m

d. 24 m; 18 m

41. Kristen lives directly east of the park. The football field is directly south of the park. The library sits on the line formed between Kristen's home and the football field at the exact point where an altitude to the right triangle formed by her home, the park, and the football field could be drawn. The library is 2 miles from her home. The football field is 5 miles from the library.

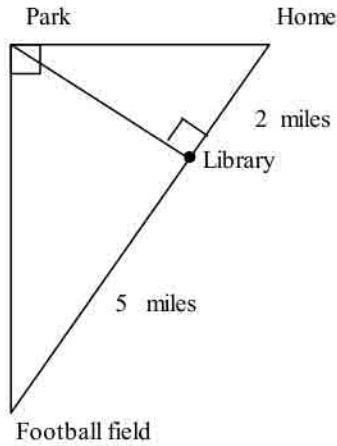

- a. How far is library from the park?  
 b. How far is the park from the football field?

- a.  $\sqrt{10}$  miles;  $\sqrt{35}$  miles  
 b.  $\sqrt{10}$  miles;  $2\sqrt{3}$  miles  
 c.  $\sqrt{7}$  miles;  $2\sqrt{3}$  miles  
 d. 4 miles; 6 miles

42. What is the value of  $x$ ?

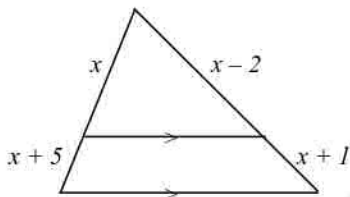

- a. 5                      b. 2.5                      c. 7.5                      d. 10

Find the length of the missing side. The triangle is not drawn to scale.

43.

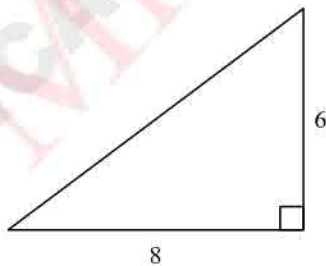

- a. 28                      b. 100                      c. 10                      d. 48

44.

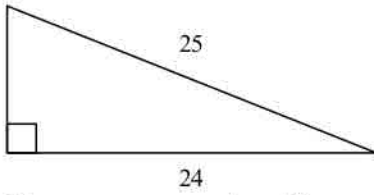

- a. 35                      b. 49                      c. 7                      d. 2

45. The figure is drawn on centimeter grid paper. Find the perimeter of the shaded figure to the nearest tenth.

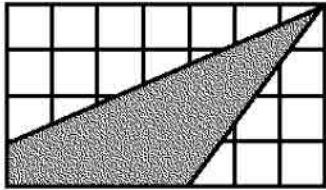

- a. 17.6 cm                      b. 10.8 cm                      c. 15.6 cm                      d. 18.0 cm

46. A triangle has sides of lengths 6, 8, and 10. Is it a right triangle? Explain.

- a. yes;  $6^2 + 8^2 \neq 10^2$                       c. no;  $6^2 + 8^2 \neq 10^2$   
 b. no;  $6^2 + 8^2 = 10^2$                       d. yes;  $6^2 + 8^2 = 10^2$

47. Find the length of the leg. If your answer is not an integer, leave it in simplest radical form.

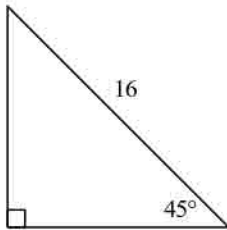

Not drawn to scale

- a. 128                      b.  $8\sqrt{2}$                       c. 16                      d.  $2\sqrt{2}$

48. Find the value of the variable. If your answer is not an integer, leave it in simplest radical form.

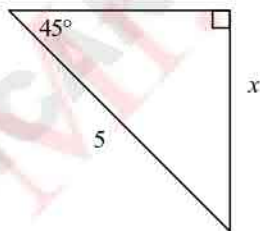

Not drawn to scale

- a.  $5\sqrt{2}$                       b.  $\frac{5\sqrt{3}}{2}$                       c.  $\frac{5\sqrt{2}}{2}$                       d.  $5\sqrt{3}$

49. The area of a square garden is  $242 \text{ m}^2$ . How long is the diagonal?

- a. 121 m                      b.  $11\sqrt{6}$  m                      c. 484 m                      d. 22 m

50. Find the value of  $x$  and  $y$  rounded to the nearest tenth.

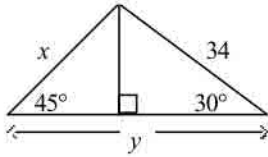

- a.  $x = 48.1, y = 46.4$                       c.  $x = 24.0, y = 139.3$   
 b.  $x = 48.1, y = 139.3$                     d.  $x = 24.0, y = 46.4$

Find the value of the variable(s). If your answer is not an integer, leave it in simplest radical form.

51.

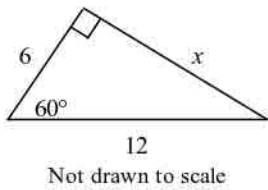

- a. 2                      b.  $12\sqrt{3}$                       c.  $\frac{1}{2}$                       d.  $6\sqrt{3}$

52.

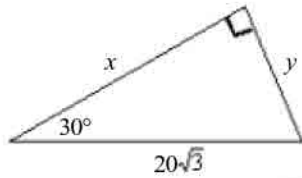

- a.  $x = 10\sqrt{3}, y = 30$                       c.  $x = 30\sqrt{3}, y = 10$   
 b.  $x = 10, y = 30\sqrt{3}$                     d.  $x = 30, y = 10\sqrt{3}$

53. Write the ratios for  $\sin X$  and  $\cos X$ .

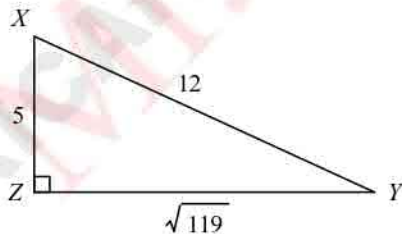

- a.  $\sin X = \frac{\sqrt{119}}{5}, \cos X = \frac{5}{\sqrt{119}}$                       c.  $\sin X = \frac{\sqrt{119}}{12}, \cos X = \frac{5}{12}$

b.  $\sin X = \frac{5}{\sqrt{119}}, \cos X = \frac{3}{\sqrt{119}}$

d.  $\sin X = \frac{5}{\sqrt{119}}, \cos X = \frac{3}{\sqrt{119}}$

54. Write the tangent ratios for  $\angle Y$  and  $\angle Z$ .

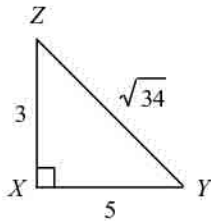

Not drawn to scale

a.  $\tan Y = \frac{5}{3}; \tan Z = \frac{3}{5}$

c.  $\tan Y = \frac{3}{\sqrt{34}}; \tan Z = \frac{5}{\sqrt{34}}$

b.  $\tan Y = \frac{\sqrt{34}}{3}; \tan Z = \frac{\sqrt{34}}{5}$

d.  $\tan Y = \frac{3}{5}; \tan Z = \frac{5}{3}$

Use a trigonometric ratio to find the value of  $x$ . Round your answer to the nearest tenth.

55.

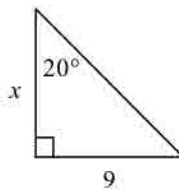

Not drawn to scale

a. 3.3

b. 3.1

c. 24.7

d. 8.5

56.

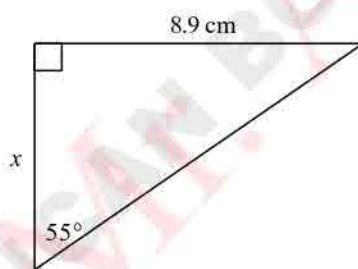

a. 6.2 cm

b. 12.7 cm

c. 15.5 cm

d. 10.9 cm

57.

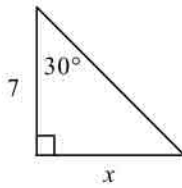

Not drawn to scale

- a. 3.5                      b. 12.1                      c. 6.1                      d. 4

Find the value of  $x$ . Round to the nearest degree.

58.

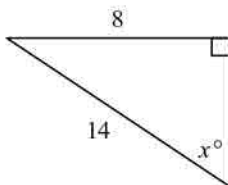

Not drawn to scale

- a. 55                      b. 35                      c. 30                      d. 34

Find the value of  $x$  to the nearest degree.

59.

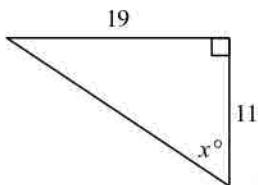

Not drawn to scale

- a. 30                      b. 60                      c. 70                      d. 85

60.

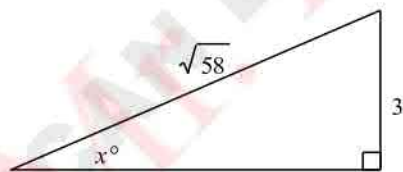

- a. 67                      b. 23                      c. 83                      d. 53

Find the area. The figure is not drawn to scale.

\_\_\_ 61.

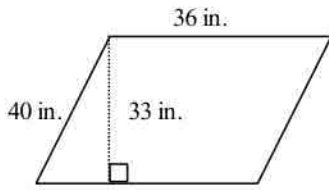

- a.  $1188 \text{ in.}^2$       b.  $69 \text{ in.}^2$       c.  $138 \text{ in.}^2$       d.  $1440 \text{ in.}^2$

\_\_\_ 62.

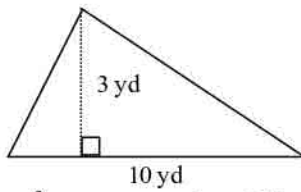

- a.  $30 \text{ yd}^2$       b.  $6.5 \text{ yd}^2$       c.  $13 \text{ yd}^2$       d.  $15 \text{ yd}^2$

\_\_\_ 63.

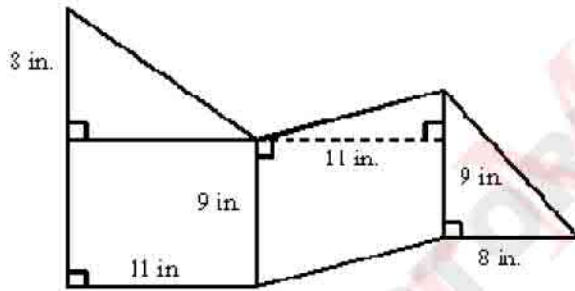

- a.  $188 \text{ in.}^2$       b.  $278 \text{ in.}^2$       c.  $322 \text{ in.}^2$       d. none of these

\_\_\_ 64.

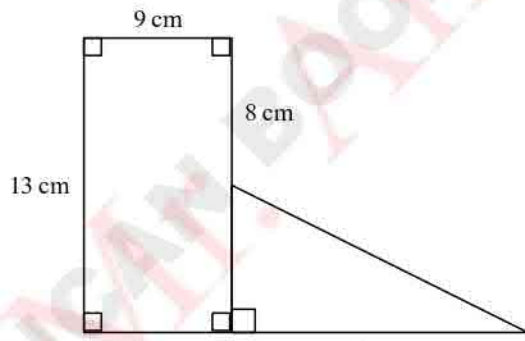

- a.  $144.5 \text{ cm}^2$       b.  $127 \text{ cm}^2$       c.  $172 \text{ cm}^2$       d.  $50 \text{ cm}^2$

**Find the area of the trapezoid. Leave your answer in simplest radical form.**

65.

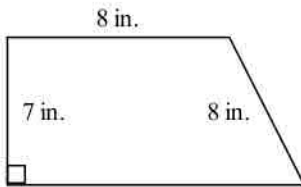

Not drawn to scale

- a.  $77.2 \text{ in.}^2$       b.  $80 \text{ in.}^2$       c.  $75 \text{ in.}^2$       d.  $70 \text{ in.}^2$

66.

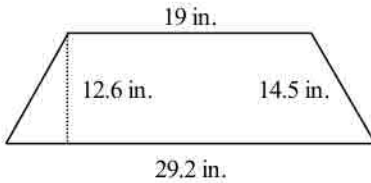

- a.  $607.32 \text{ in.}^2$       b.  $36.7 \text{ in.}^2$       c.  $303.66 \text{ in.}^2$       d.  $77.2 \text{ in.}^2$

67.

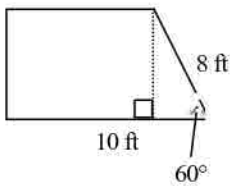

Not drawn to scale

- a.  $40\sqrt{3} \text{ ft}^2$       b.  $16\sqrt{3} \text{ ft}^2$       c.  $24\sqrt{3} \text{ ft}^2$       d.  $32\sqrt{3} \text{ ft}^2$

68.

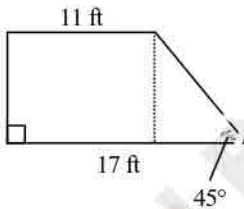

Not drawn to scale

- a.  $84\sqrt{2} \text{ ft}^2$       b.  $84 \text{ ft}^2$       c.  $168 \text{ ft}^2$       d.  $14 \text{ ft}^2$

Find the circumference. Leave your answer in terms of  $\pi$ .

69.

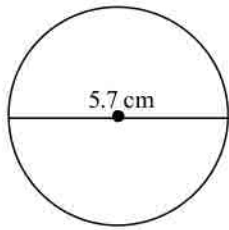

- a.  $11.4\pi$  cm      b.  $8.55\pi$  cm      c.  $2.85\pi$  cm      d.  $5.7\pi$  cm

70.

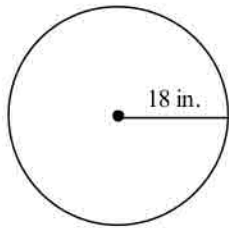

- a.  $54\pi$  in.      b.  $36\pi$  in.      c.  $18\pi$  in.      d.  $324\pi$  in.

71. Find the length of  $\widehat{XPY}$ . Leave your answer in terms of  $\pi$ .

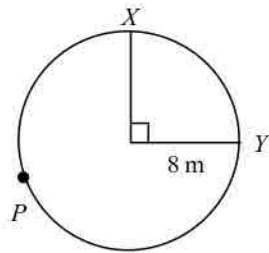

- a.  $24\pi$  m      b.  $12\pi$  m      c.  $4\pi$  m      d.  $720\pi$  m

72. The figure represents the overhead view of a deck surrounding a hot tub. What is the area of the deck? Round to the nearest tenth.

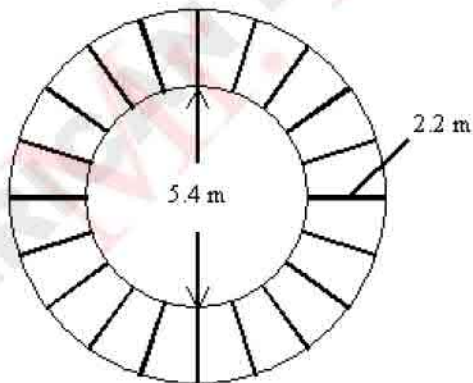

- a.  $75.4 \text{ m}^2$       b.  $52.5 \text{ m}^2$       c.  $278.7 \text{ m}^2$       d.  $22.9 \text{ m}^2$

Find the area of the circle. Leave your answer in terms of  $\pi$ .

73.

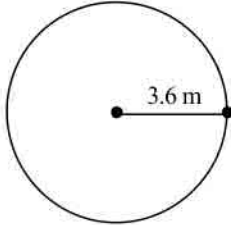

- a.  $25.92\pi \text{ m}^2$       b.  $1.8\pi \text{ m}^2$       c.  $12.96\pi \text{ m}^2$       d.  $46.66\pi \text{ m}^2$

74.

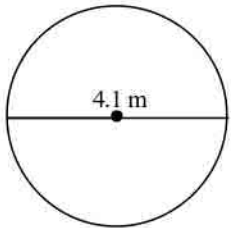

- a.  $4.2025\pi \text{ m}^2$       b.  $8.405\pi \text{ m}^2$       c.  $16.81\pi \text{ m}^2$       d.  $11.2\pi \text{ m}^2$

75. Find the area of the shaded portion of the figure. Dimensions are in feet. Leave your answer in terms of  $\pi$ . The figure is not drawn to scale.

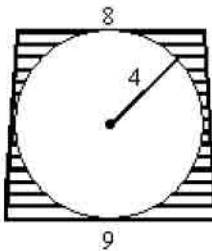

- a.  $(68 - 8\pi) \text{ ft}^2$       b.  $(72 - 16\pi) \text{ ft}^2$       c.  $(68 - 16\pi) \text{ ft}^2$       d. none of these

76. Find the area of the figure to the nearest tenth.

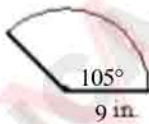

- a.  $74.2 \text{ in.}^2$       b.  $8.2 \text{ in.}^2$       c.  $148.4 \text{ in.}^2$       d.  $23.6 \text{ in.}^2$

77. Find the area of the shaded portion of the figure. Each vertex of square  $ABCD$  is at the center of a circle. Leave your answer in terms of  $\pi$ .

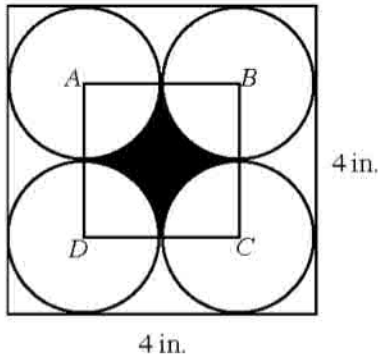

- a.  $(4 - \pi) \text{ in.}^2$       b.  $\left(4 - \frac{1}{2}\pi\right) \text{ in.}^2$       c.  $\left(4 - \frac{\pi}{4}\right) \text{ in.}^2$       d.  $\pi \text{ in.}^2$

78. Find the area of a sector with a central angle of  $180^\circ$  and a diameter of 5.6 cm. Round to the nearest tenth.  
 a.  $49.2 \text{ cm}^2$       b.  $12.3 \text{ cm}^2$       c.  $2.2 \text{ cm}^2$       d.  $5.6 \text{ cm}^2$
79. The area of sector  $AOB$  is  $20.25\pi \text{ ft}^2$ . Find the exact area of the shaded region.

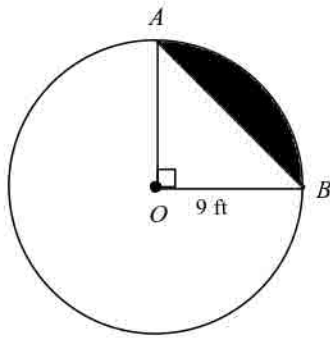

- a.  $(20.25\pi - 40.5) \text{ ft}^2$       c.  $(20.25\pi - 40.5\sqrt{2}) \text{ ft}^2$   
 b.  $(20.25\pi - 81) \text{ ft}^2$       d. none of these

Assume that lines that appear to be tangent are tangent.  $O$  is the center of the circle. Find the value of  $x$ . (Figures are not drawn to scale.)

80.  $m\angle P = 12$

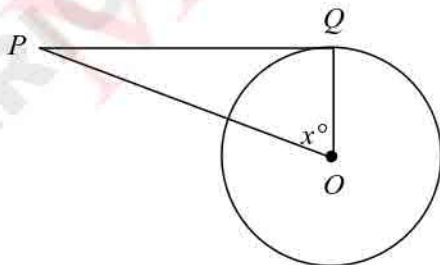

- a. 78      b. 39      c. 102      d. 24

In the figure,  $\overrightarrow{PA}$  and  $\overrightarrow{PB}$  are tangent to circle  $O$  and  $\overrightarrow{PD}$  bisects  $\angle BPA$ . The figure is not drawn to scale.

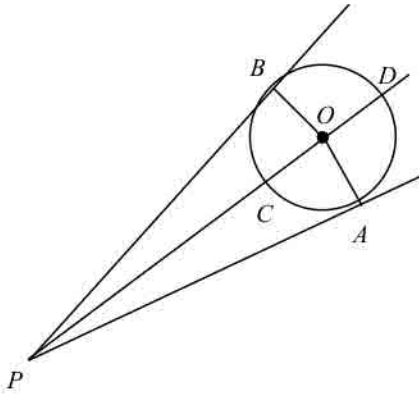

81. For  $m\angle AOC = 46$ , find  $m\angle POB$ .  
 a. 23                      b. 90                      c. 46                      d. 68
82. For  $m\angle AOC = 50$ , find  $m\angle BPO$ .  
 a. 40                      b. 50                      c. 65                      d. 140
83.  $\overline{AB}$  is tangent to  $\odot O$ . If  $AO = 24$  and  $BC = 50$ , what is  $AB$ ?  
 The diagram is not to scale.

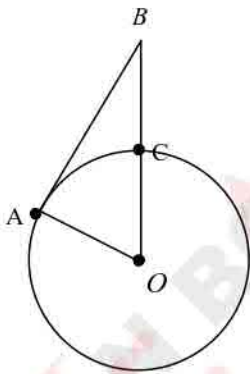

- a. 74                      b. 94                      c. 70                      d. 100
84. A satellite is 13,200 miles from the horizon of Earth. Earth's radius is about 4,000 miles. Find the approximate distance the satellite is from the Earth's surface.  
 The diagram is not to scale.

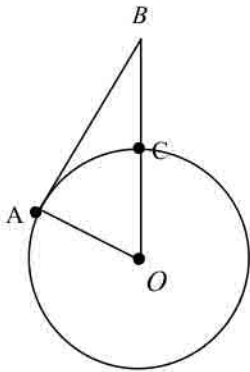

- a. 13,793 miles      b. 17,200 miles      c. 9,793 miles      d. 16,552 miles

85.  $\overline{BC}$  is tangent to circle  $A$  at  $B$  and to circle  $D$  at  $C$  (not drawn to scale).  $AB = 10$ ,  $BC = 21$ , and  $DC = 8$ . Find  $AD$  to the nearest tenth.

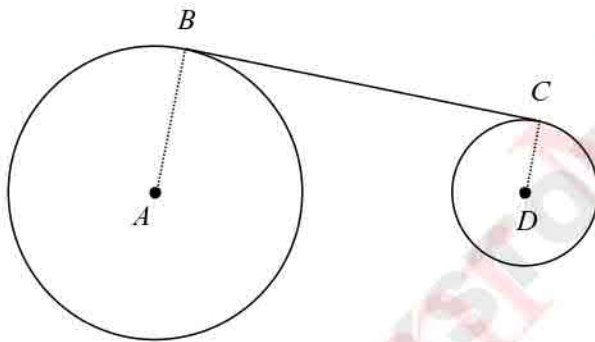

- a. 22.5      b. 21.1      c. 23.3      d. 27.7

86. A chain fits tightly around two gears as shown. The distance between the centers of the gears is 20 inches. The radius of the larger gear is 11 inches. Find the radius of the smaller gear. Round your answer to the nearest tenth, if necessary. The diagram is not to scale.

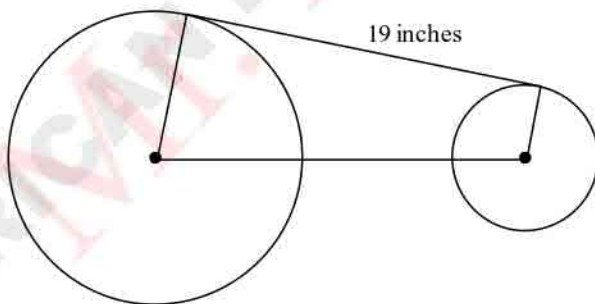

- a. 17.2 inches      b. 6.2 inches      c. 11 inches      d. 4.8 inches

87.  $\overline{JK}$ ,  $\overline{KL}$ , and  $\overline{LJ}$  are all tangent to  $O$  (not drawn to scale).  $JA = 9$ ,  $AL = 10$ , and  $CK = 14$ . Find the perimeter of  $\triangle JKL$ .

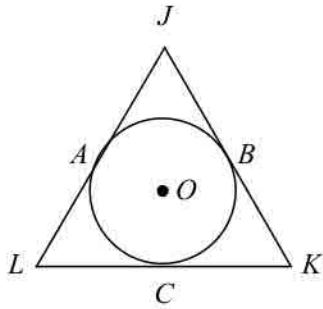

88. a. 66                      b. 38                      c. 46                      d. 33  
 $\overline{NA} \cong \overline{PA}$ ,  $\overline{MO} \perp \overline{NA}$ ,  $\overline{RO} \perp \overline{PA}$ ,  $MO = 3$  ft  
 What is  $PO$ ?

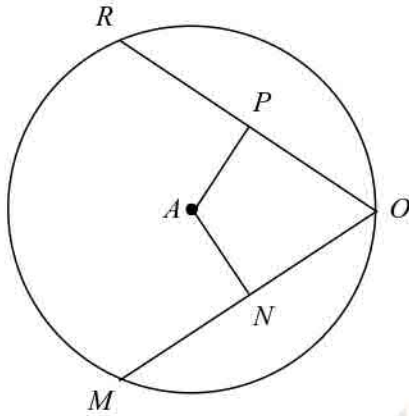

89. a. 1.5 ft                      b. 6 ft                      c. 9 ft                      d. 3 ft  
 $\overline{BZ} \cong \overline{FZ}$ ,  $\overline{BZ} \perp \overline{CA}$ ,  $\overline{FZ} \perp \overline{DC}$ ,  $DF = 18$  in.  
 What is  $BC$ ?

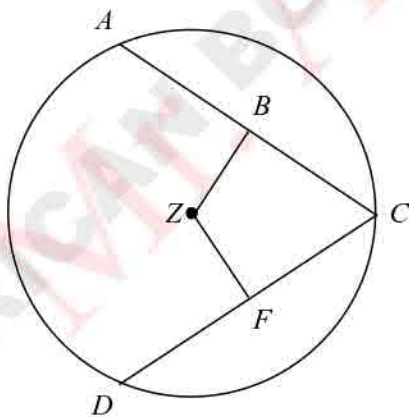

- a. 36 in.                      b. 18 in.                      c. 27 in.                      d. 9 in.

Find the value of  $x$ . If necessary, round your answer to the nearest tenth. The figure is not drawn to scale.

90.

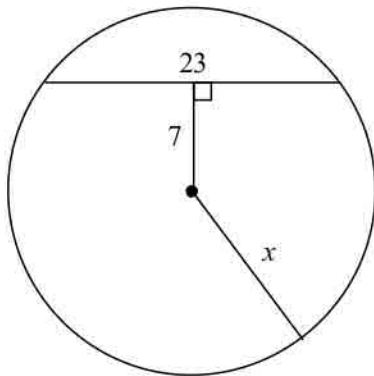

- a. 21.9                      b. 181.3                      c. 24                      d. 13.5

91. Find the measure of  $\angle BAC$ . (The figure is not drawn to scale.)

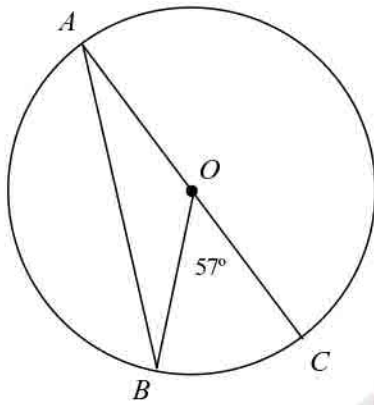

- a. 57                      b. 28.5                      c. 33                      d. 114

92. Find  $x$ . (The figure is not drawn to scale.)

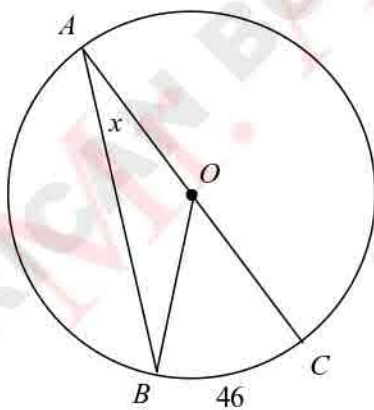

- a. 92                      b. 44                      c. 23                      d. 46

93. Find  $m\angle BAC$ . (The figure is not drawn to scale.)

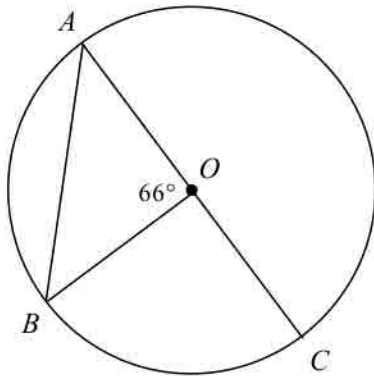

- a. 114                      b. 57                      c. 132                      d. 33

94.  $m\angle R = 22$ . Find  $m\angle O$ . (The figure is not drawn to scale.)

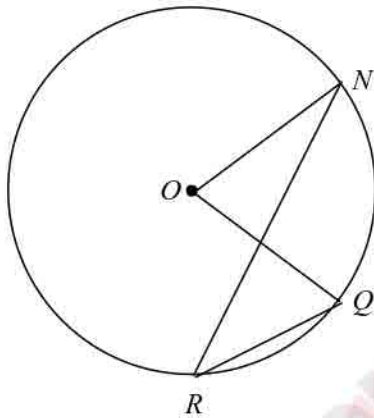

- a. 68                      b. 22                      c. 158                      d. 44

95. Given that  $\angle DAB$  and  $\angle DCB$  are right angles and  $m\angle BDC = 47^\circ$ , what is  $m\widehat{CAD}$ ? (The figure is not drawn to scale.)

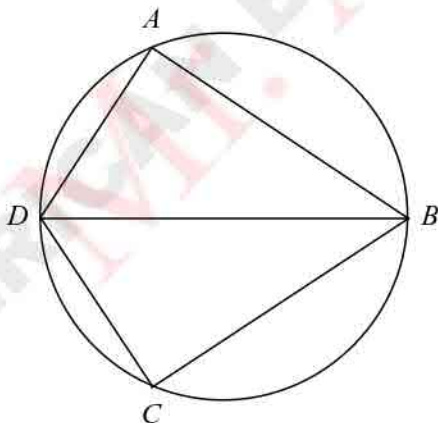

- a. 321                      b. 282                      c. 188                      d. 274

96. If  $m\angle CDB = 31$ , what is  $m\angle CAB$ ?

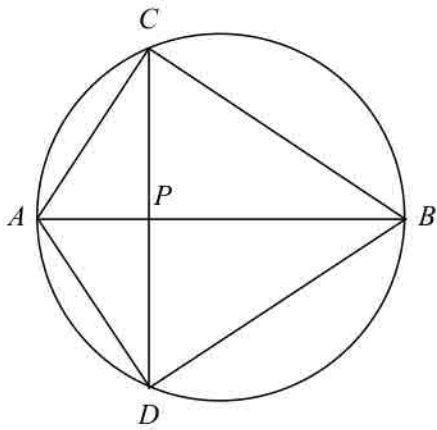

a. 59

b. 31

c. 15.5

d. 149

AMERICAN BOOKSTORE TEL: 201-953-89184

Answer Section

MULTIPLE CHOICE

1. D
2. A
3. C
4. A
5. C
6. B
7. A
8. B
9. A
10. A
11. C
12. C
13. A
14. A
15. B
16. B
17. A
18. A
19. B
20. B
21. D
22. D
23. D
24. D
25. D
26. B
27. B
28. D
29. C
30. A
31. A
32. B
33. D
34. B
35. B
36. A
37. A
38. A
39. B
40. A
41. A
42. A
43. C
44. C
45. A

46. D
47. B
48. C
49. D
50. D
51. D
52. D
53. C
54. D
55. C
56. A
57. D
58. B
59. B
60. B
61. A
62. D
63. B
64. A
65. D
66. C
67. D
68. B
69. D
70. B
71. B
72. B
73. C
74. A
75. C
76. A
77. A
78. B
79. A
80. A
81. C
82. C
83. C
84. C
85. B
86. D
87. A
88. A
89. B
90. D
91. B
92. C
93. B
94. D
95. D
96. B

## Probability

1. A dice is thrown. Find the probability of getting an even number.

- (A)  $\frac{2}{3}$  (B) 1  
(C)  $\frac{5}{6}$  (D)  $\frac{1}{2}$

**Answer: (D)**

**Explanation:** Total number of cases = 6 (1,2,3,4,5,6)

There are three even numbers 2,4,6

Therefore probability of getting an even number is:

$$P(\text{even}) = \frac{3}{6}$$
$$\Rightarrow P(\text{even}) = \frac{1}{2}$$

2. Two coins are thrown at the same time. Find the probability of getting both heads.

- (A)  $\frac{3}{4}$  (B)  $\frac{1}{4}$   
(C)  $\frac{1}{2}$  (D) 0

**Answer: (B)**

**Explanation:** Since two coins are tossed, therefore total number of cases =  $2^2 = 4$

Therefore, probability of getting heads in both coins is:

$$\therefore P(\text{head}) = \frac{1}{4}$$

3. Two dice are thrown simultaneously. The probability of getting a sum of 9 is:

- (A)  $\frac{1}{10}$  (B)  $\frac{3}{10}$   
(C)  $\frac{1}{9}$  (D)  $\frac{4}{9}$

**Answer: (C)**

**Explanation:** Total cases = 36

Total cases in which sum of 9 can be obtained are:

$$(5, 4), (4, 5), (6, 3), (3, 6)$$

$$\therefore P(9) = \frac{4}{36} = \frac{1}{9}$$

4. 100 cards are numbered from 1 to 100. Find the probability of getting a prime number.

- (A)  $\frac{3}{4}$  (B)  $\frac{27}{50}$   
(C)  $\frac{1}{4}$  (D)  $\frac{29}{100}$



7. Cards marked with numbers 2 to 101 are placed in a box and mixed thoroughly. One card is drawn from this box randomly, then the probability that the number on card is a perfect square.

- (A)  $9/100$  (B)  $1/10$   
(C)  $3/10$  (D)  $19/100$

**Answer: (B)**

**Explanation:** The perfect square numbers between 2 to 101 are:

1, 4, 9, 16, 25, 36, 49, 64, 81, 100

Total numbers from 2 to 101 = 100

So probability of getting a card with perfect square number is:

$$P(\text{perfect square}) = \frac{10}{100}$$

$$\Rightarrow P(\text{perfect square}) = \frac{1}{10}$$

8. What is the probability of getting 53 Mondays in a leap year?

- (A)  $1/7$  (B)  $53/366$   
(C)  $2/7$  (D)  $7/366$

**Answer: (C)**

**Explanation:** With 366 days, the number of weeks in a year is

$$\frac{366}{7} = 52 \frac{2}{7}$$

i.e., 52 complete weeks which contains 52 Mondays,

Now 2 days of the year are remaining.

These two days can be

(Sunday, Monday), (Monday, Tuesday), (Tuesday, Wednesday),  
(Wednesday, Thursday), (Thursday, Friday), (Friday, Saturday),  
(Saturday, Sunday)

i.e., there are 7 pairs, in which Monday occurs in 2 pairs,

So probability is:

$$P(53 \text{ monday}) = \frac{2}{7}$$

9. A card is drawn from a well shuffled deck of 52 cards. Find the probability of getting a king of red suit.

- (A)  $1/26$  (B)  $3/26$   
(C)  $7/52$  (D)  $1/13$

**Answer: (A)**

**Explanation:** There are total 4 kings in 52 cards, 2 of red colour and 2 of black colour  
Therefore, Probability of getting a king of red suit is:

$$P(\text{King of red suit}) = \frac{2}{52}$$
$$\Rightarrow P(\text{King of red suit}) = \frac{1}{26}$$

**10.** A game of chance consists of spinning an arrow which is equally likely to come to rest pointing to one of the number 1,2,3.....12 ,then the probability that it will point to an odd number is:

- (A) 1/6 (B) 1/12  
(C) 7/12 (D) 5/12

**Answer: (A)**

**Explanation:** The odd numbers in 1,2,3... ..... 12 are:

1,3,5,7,9,11

Therefore probability that an odd number will come is:

$$P(\text{odd number}) = \frac{6}{12}$$
$$\Rightarrow P(\text{odd number}) = \frac{1}{2}$$

**11.** A game consists of tossing a one rupee coin 3 times and noting its outcome eachtime. Aryan wins if all the tosses give the same result i.e. three heads or three tails and loses otherwise. Then the probability that Aryan will lose the game.

- (A) 3/4 (B) 1/2  
(C) 1 (D) 1/4

**Answer: (A)**

**Explanation:** Total outcomes are:

HHH, HHT, HTH, THH, HTT, THT, TTH, TTT

Favourable outcomes for losing game are

HHT, HTH, THH, HTT, THT, TTH

Therefore probability of losing the game is:

$$P(\text{Losing the game}) = \frac{6}{8}$$

$$P(\text{Losing the game}) = \frac{3}{4}$$

**12.** Riya and Kajal are friends. Probability that both will have the same birthday is the same birthday is:

- (A)  $364/365$  (B)  $31/365$   
 (C)  $1/365$  (D)  $1/133225$

**Answer: (C)**

**Explanation:**

Riya may have any one of 365 days of the year as her birthday. Similarly Kajal may have any one of 365 days as her birthday.

Total number of ways in which Riya and Kajal may have their birthday are:

$$365 \times 365$$

Then Riya and Kajal may have same birthday on any one of 365 days.

Therefore number of ways in which Riya and Kajal may have same birthday are:

$$= \frac{365}{365 \times 365}$$

$$= \frac{1}{365}$$

**13.** A number  $x$  is chosen at random from the numbers -2, -1, 0, 1, 2. Then the probability that  $x^2 < 2$  is?

- (A)  $1/5$  (B)  $2/5$   
 (C)  $3/5$  (D)  $4/5$

**Answer: (C)**

**Explanation:** We have 5 numbers -2, -1, 0, 1, 2

Whose squares are 4, 1, 0, 1, 4

So square of 3 numbers is less than 2

Therefore Probability is:

$$P(x^2 < 2) = \frac{3}{5}$$

14. A jar contains 24 marbles. Some are red and others are white. If a marble is drawn at random from the jar, the probability that it is red is  $\frac{2}{3}$ , then the number of white marbles in the jar is:

- (A) 10 (B) 6  
(C) 8 (D) 7

**Answer: (C)**

**Explanation:** Let the number of white marbles be  $x$ .

Since only two colour marbles are present, and total probability we know of all the events is equal to 1.

$$P(\text{white}) = 1 - P(\text{red})$$

$$\frac{x}{24} = 1 - \frac{2}{3}$$

$$\Rightarrow \frac{x}{24} = \frac{1}{3}$$

$$\Rightarrow x = 8$$

So there are 8 white marbles.

15. A number is selected at random from first 50 natural numbers. Then the probability that it is a multiple of 3 and 4 is:

- (A)  $\frac{7}{50}$  (B)  $\frac{4}{25}$   
(C)  $\frac{1}{25}$  (D)  $\frac{2}{25}$

**Answer: (D)**

**Explanation:** The numbers that are multiple of 3 (from first 50 natural numbers) are:

3, 6, 9, 12, 15, 18, ..... 48

The numbers that are multiple of 4 (from first 50 natural numbers) are:

4, 8, 12, 16, ..... 48

The numbers that are multiples of 3 and 4 both are the multiples of  $3 \times 4 = 12$  as both 3 and 4 are co-prime.

So common multiples are:

12, 24, 36, 48

Therefore probability is:

$$P(\text{multiple of 3 and 4}) = \frac{4}{50}$$

$$\Rightarrow P(\text{multiple of 3 and 4}) = \frac{2}{25}$$

### Tree Diagram Probability

James goes to an arcade.

He has one go on the Teddy Grabber.

He has one go on the Penny Drop.

The probability that he wins on the Teddy Grabber is 0.2.

The probability that he wins on the Penny Drop is 0.3.

(a) Complete the tree diagram.

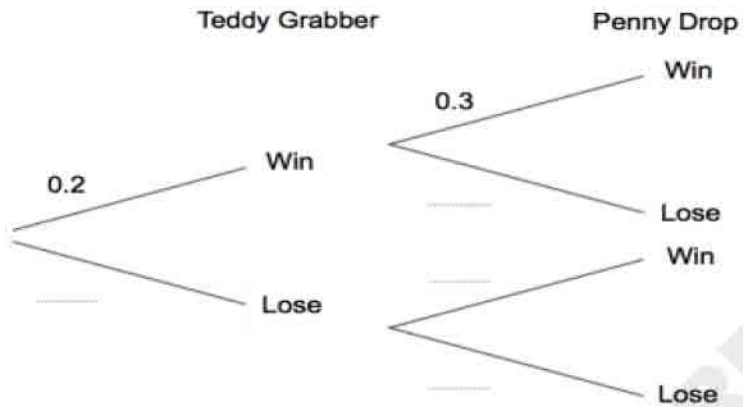

(2)

(b) Work out the probability that James wins on the Teddy Grabber and he also wins on the Penny Drop.

A box contains 2 red marble, 3 white marble, 4 green marbles and 1 blue marble. Two marbles are drawn at random without replacement. Find the probability of

Problems

Work Space

Selecting a green marble in a second draw if the first marble is blue.

Answer:  $\frac{4}{9}$

Selecting a white marble in a first draw and red marble in a second draw.

Answer:  $\frac{3}{10} \times \frac{2}{9} = \frac{1}{15}$

Selecting red marbles in both draws.

Answer:  $\frac{2}{10} \times \frac{1}{9} = \frac{1}{45}$

Selecting red or white in a first draw and green or blue in second draw.

Answer:  $\frac{5}{10} \times \frac{5}{9} = \frac{5}{18}$

Selecting white marble in a first draw and white or blue in a second draw.

Answer:  $\frac{3}{10} \times \frac{3}{9} = \frac{1}{10}$